

# Good-for-Game QPTL: An Alternating Hodges Semantics

DYLAN BELLIER, Université Rennes 1, France

MASSIMO BENERECETTI, Università degli Studi di Napoli Federico II, Italy

DARIO DELLA MONICA, Università degli Studi di Udine, Italy

FABIO MOGAVERO, Università degli Studi di Napoli Federico II, Italy

An extension of QPTL is considered where *functional dependencies* among the quantified variables can be restricted in such a way that their current values are *independent of the future* values of the other variables. This restriction is tightly connected to the notion of *behavioral strategies* in game-theory and allows the resulting logic to naturally express game-theoretic concepts. Inspired by the work on logics of dependence and independence, we provide a new compositional semantics for QPTL that allows for expressing such functional dependencies among variables. The fragment where only restricted quantifications are considered, called *behavioral quantifications*, allows for linear-time properties that are satisfiable if and only if they are realisable in the Pnueli-Rosner sense. This fragment can be decided, for both *model checking* and *satisfiability*, in 2EXPTIME and is *expressively equivalent* to QPTL, though significantly *less succinct*.

CCS Concepts: • **Theory of computation** → **Modal and temporal logics**; *Logic and verification*; **Automata over infinite objects**.

## ACM Reference Format:

Dylan Bellier, Massimo Benerecetti, Dario Della Monica, and Fabio Mogavero. . Good-for-Game QPTL: An Alternating Hodges Semantics. *ACM Trans. Comput. Logic* 0, 0, Article 0 ( ), 57 pages.

## 1 INTRODUCTION

The tight connection between *logic* and *games* has been acknowledged since the sixties, when first Lorenzen [54] and later Lorenz [53] and Hintikka [34] proposed *game-theoretic semantics* for first-order logic [36, 39]. In this approach, the meaning of a sentence is given in terms of a zero-sum game played by two agents: the *verifier*, whose objective is to show the sentence true, and the *falsifier*, with the dual objective of showing the sentence false. Satisfiability of a sentence, then, becomes a game between these two players and the sentence is satisfiable (*resp.*, unsatisfiable) *iff* verifier (*resp.*, falsifier) has a strategy to win the game. This tight connection can clearly be viewed in the other direction as well: logic can be used to reason about games, *i.e.*, we can encode the problem of solving a game into a *decision problem*, such as *satisfiability* or *model-checking*, of some logic. The idea is to describe the game and the *winning condition* with a formula of the logic and exploit the *game-theoretic interpretation* to reduce the solution of the game to a specific decision problem for that logic. Essentially, the winning strategy for the game can be extracted from the winning strategy for the *decision game*.

---

Authors' addresses: Dylan Bellier, Université Rennes 1, Rennes, France, dylan.bellier@irisa.fr; Massimo Benerecetti, Università degli Studi di Napoli Federico II, Napoli, Italy, massimo.benerecetti@unina.it; Dario Della Monica, Università degli Studi di Udine, Udine, Italy, dario.dellamonica@uniud.it; Fabio Mogavero, Università degli Studi di Napoli Federico II, Napoli, Italy, fabio.mogavero@unina.it.

---

Permission to make digital or hard copies of all or part of this work for personal or classroom use is granted without fee provided that copies are not made or distributed for profit or commercial advantage and that copies bear this notice and the full citation on the first page. Copyrights for components of this work owned by others than ACM must be honored. Abstracting with credit is permitted. To copy otherwise, or republish, to post on servers or to redistribute to lists, requires prior specific permission and/or a fee. Request permissions from [permissions@acm.org](mailto:permissions@acm.org).

© 2021 Association for Computing Machinery.

1529-3785/0-ART0 \$15.00

<https://doi.org/>

Suppose we have a formula  $\psi(x, y)$ , expressing a required relation between the choice  $y$  made by a player, from now on called *Eloise*, and a choice  $x$  made by the adversary, namely *Abelard*, i.e.,  $\psi(x, y)$  encodes the *objective* of a two-player game. We say that the game is won by Eloise if there exists a *strategy* for her such that, for each choice  $x$  made by Abelard, the corresponding response  $y$  of Eloise using that strategy guarantees that the resulting play satisfies the requirement  $\psi(x, y)$ . This condition can clearly be expressed by a sentence of the form  $\forall x. \exists y. \psi(x, y)$ . We could then solve the game by solving the satisfiability problem for this sentence. In other words, solving the game reduces to checking whether there exists a *Skolem function*  $f$  such that  $\forall x. \psi(x, f(x))$  is satisfied. This function basically dictates the response of Eloise to the choice of Abelard, thereby encoding her strategy.

The above approach works pretty well when we consider *single-round games, a.k.a., normal-form games* [85], and can easily be extended to *finite-rounds games, a.k.a., extensive-form games* [49, 50, 84], by extending the quantification prefix to a sequence of alternations of quantifiers, one for each round. Things, however, get much more complicated when *infinite-rounds games* come into play [22, 86]. For such a class of extensive-form games, indeed, plays are induced by infinite sequences of choices made by the players over time and a strategy dictates how a player at a given stage of a play responds to the choices made by the adversary up to that stage. Extending the quantification prefix to match the rounds would immediately lead to *infinitary logics*, such as the one proposed by Kolaitis [46] and further studied by Heikkilä and Väänänen [30] (see also [37]). This technique has some interesting applications in logic [31], computer science [44], and even philosophy [21]. Besides its infinitary nature, however, this approach has also the drawback of heavily departing from the standard Tarskian viewpoint, as only non-compositional game-theoretic semantics have been provided.

A more viable route, instead, is to make the quantified variables  $x$  and  $y$  range over sequences of choices. For example, when the choices are simply *Boolean values*, *iterated Boolean games* are to be considered [28, 29]. Then, first-order extensions of *temporal logics*, such as *Quantified Propositional Temporal Logic* (QPTL) [77], seem like a good place to start, as they predicate over infinite sequences of temporal points (the stages of the game). In this setting, however, the Skolem function  $f$  cannot be interpreted as a strategy in the game-theoretic sense anymore, since its value at a given stage depends on the entire evaluation of its argument  $x$ , namely the entire sequence of choices made by the adversary, including all the future ones. By contrast, a strategy for a player can only dictate, step by step, what its responses should be, depending on the choices made so far by its opponent. What that means is that, in principle, the satisfiability and the game solution problems do not coincide anymore. A classic example of this problem has already been observed by Pnueli and Rosner [72]. Assume  $\psi(x, y)$  is the LTL [70, 71] formula  $G(y \leftrightarrow Xx)$  (or just  $y \leftrightarrow Xx$ ). Clearly, the sentence  $\forall x. \exists y. \psi(x, y)$  is satisfiable. However, there is no “feasible” (i.e., implementable) strategy that can enforce  $\psi(x, y)$ , without Eloise knowing in advance the future values that Abelard is going to choose for  $x$  in the rest of the play. The problem is that the standard interpretation of quantification treats the quantified objects as *atomic entities*, regardless of their *inner structure*, like their being sequences in the above example. This is by no means the only exemplification of the problem, which was already recognised in the theory of extensive-form games since its dawn [49], where the notion of feasible strategy, called *behavioral*, has been introduced (see also [48, 50, 67, 76]). Another important source of unfeasible strategic behaviours is hidden in the semantics of *Strategy Logic* (SL) [8, 9, 59, 60, 63], an extension of LTL that allows for explicit *quantifications* over strategies and *binding* of strategies with players. In this logic, formulae can be written that can be satisfied only by allowing players to look at what other strategies dictate in the future or counterfactual situations [61, 62], admitting infeasible behaviours. Once again, the problem lies in the intrinsic dependence among the strategy variables quantified in the specific formula.

One way to reconcile quantifications and strategies in a temporal setting would be to extend the game-theoretic interpretation of the quantifiers, and of the logic in general, to account for the underlying temporal dynamics. This would imply allowing the players in the satisfiability game to play with partial information on the choices of the adversary, namely the players have no information about the future and can only choose based on the moves played so far in the game. Previous attempts to address the issue typically involve resorting to *ad hoc Skolem semantics* [40] for the specific logic. In the case of SL, for instance, the notion of *behavioral semantics* has been introduced [59], which prevents the players from looking at future choices when selecting their strategy, effectively limiting the player observation ability to the current history in the game. A more liberal semantics based on *timeline dependencies* has been also proposed [23, 24]. Recently, the same semantic approach has been ported to QPTL [25]. While these approaches do solve the problem in each specific case, they lead to non-compositional semantics [74], in that the interpretation of a formula is not defined in terms of the interpretation of its component subformulae. To obtain a compositional version of the game-theoretic semantics, a finer grained technical setting is required, compared to the classic Tarskian semantics, specifically, one that can accommodate some form of *partial independence* among the quantified variables.

Following Tarski's approach, each choice for a quantified variable in a sentence is made with complete information about, hence it is (potentially) completely dependent on, the values of variables quantified before it in the sentence. This idiosyncrasy of the classic interpretation of quantifiers is well known and attempts have been made to overcome the *linear dependence* of quantifiers dictated by their relative position in a sentence [5, 32, 35, 75]. Most notably, Hintikka and Sandu [38] proposed *Independence-Friendly Logic* (IF), as a first-order logic where independence between quantified variables can be explicitly asserted in the formulae together with a game-theoretic, non-compositional, semantics [73] for the logic. A compositional semantics for IF was later proposed by Hodges [41, 42], whose idea was to replace the standard notion of *assignment* of the Tarskian semantics with that of set of assignments (called *trump* [41] or *team* [79]), as the basic semantic element with respect to which the truth of a formula is evaluated. This multiplicity of assignments effectively allows one to express the notion of *dependence/independence* among variables, a distinction that makes very little sense, in particular from a formal point of view, when only a single assignment is considered.

Taking inspiration from Hodges' work, the goal of this work is to devise a *compositional semantic framework* that can account for a game-theoretic interpretation of quantification over (possibly infinite) sequences of choices. The framework is specifically tailored to deal with quantifications in a linear time setting and applied to the logic QPTL, which was introduced by Sistla [77] as a unifying  $\omega$ -regular language allowing for both temporal operators and propositional quantifiers. Despite its expressiveness and theoretical interest, QPTL has not gained much traction in practical contexts, mainly due to the high complexity of its decision problems. Indeed, both the satisfiability and the model checking problems are *non-elementary* in the number of *alternations of the quantifiers* [78].

In this article we propose a novel semantics for QPTL, inspired by the body of work on (in)dependence logics [1, 55, 79]. Application of Hodges-like semantics in the temporal context, though with very different objectives, have recently been proposed. For instance, Krebs et al. [47] and Virtema et al. [83] introduce a team semantics for the linear temporal logic LTL, with the aim of expressing temporal hyperproperties [11], namely properties involving sets of timelines at once, in a similar vein as HyperLTL [10]. Similarly to the works mentioned above, the semantics we propose here provides a compositional formulation [74] for a game-theoretic interpretation of the quantifiers. In contrast to them, however, we require a *symmetric* treatment of the two quantifiers in order to preserve *closure under negation* and avoid *undetermined formulae* [41, 42]. The most significant feature of the new approach is the ability to encode various forms of *independence*

*constraints* among the quantified variables and provide a powerful tool to fine-tune the semantics of the propositional quantifiers. In particular, we discuss a specific instantiation of the semantics that allows one to recover a game-theoretic interpretation of the quantifiers and reconcile the satisfiability and the game solution problems. This result is achieved by first generalising classic *temporal assignments*, which give values to propositional variables at each time instant, to sets of sets of assignments, called *hyperassignments*. This also generalises teams, defined as sets of assignments, used by Hodges. The second step is to introduce new *classes of functors* that map temporal assignments to valuations of a given variable over time and, intuitively, correspond to the semantic counterparts of the Skolem functions. The dependence of functors on assignments allows us to impose various forms of independence constraints among the variables. In particular, we investigate two specific forms, called *behavioral* and *strongly-behavioral*, that require functors to choose the value of the variable at any given time instant based only upon the values dictated by the input assignment to the other variables up to that instant (possibly excluded). These are forms of independence constraints that make the choice of the value of a variable at a given time totally independent of the values that other variables assume in the future. The behavioral restrictions are precisely what allows us to recover the correspondence between Skolem functions and strategies and to reconcile the satisfiability and game solution problems, thus making the resulting version of QPTL, called *Good-for-Games QPTL* (GFG-QPTL), well suited to express game-theoretic concepts and a logical analogue of *Good-for-Games Automata* [6, 33].

On the technical side, the novel semantics under the behavioral interpretation of the quantifiers leads to 2ExpTIME decision procedures for both the satisfiability and model-checking problems. On the other hand, it does not give up expressiveness, as we show that the vanilla and behavioral semantics turn out to be expressively equivalent. These results also show that the high complexity of the decision problems for vanilla QPTL stems from the fact that unrestricted dependencies among the quantified variables are allowed. The properties expressible by exploiting such unrestricted dependencies can, however, still be expressed under the behavioral semantics via encoding of  $\omega$ -regular automata, though with a non-elementary blowup.

## 2 ALTERNATING HODGES SEMANTICS

QPTL [77] extends LTL [70, 71] with quantifications over *atomic propositions* from a given set AP, with the intuition that the Boolean values of the same proposition in different time instants are independent of each other.

### 2.1 Quantified Propositional Temporal Logic

For convenience, we provide a syntax for QPTL where quantifications do not occur within temporal operators. This is equivalent to the original logic, thanks to the *prenex normal form* (*pnf*, for short) property enjoyed by QPTL [77], which allows to move quantifiers outside temporal operators.

**DEFINITION 1 (QPTL SYNTAX).** *The Quantified Propositional Temporal Logic is the set of formulae built accordingly to the following context-free grammar, where  $\psi \in \text{LTL}$  and  $p \in \text{AP}$ :*

$$\varphi := \psi \mid \neg\varphi \mid \varphi \wedge \varphi \mid \varphi \vee \varphi \mid \exists p. \varphi \mid \forall p. \varphi.$$

The classic semantics is given in terms of *temporal assignments* (simply *assignments*, from now on), which are functions associating each proposition with a *temporal valuation* mapping each time instant to a Boolean value, *i.e.*, infinite sequences of truth assignments. Let  $\text{Asg} \triangleq \text{AP} \rightarrow (\mathbb{N} \rightarrow \mathbb{B})$  be the set of assignments over arbitrary subsets of AP, with  $\mathbb{B} \triangleq \{\perp, \top\}$ , where the notation  $A \rightarrow B$  stands for the set of partial functions with potential domain A and codomain B.

For convenience, we also introduce the set of assignments defined exactly over the propositions in  $P \subseteq AP$ , *i.e.*,  $\text{Asg}(P) \triangleq \{\chi \in \text{Asg} \mid \text{dom}(\chi) = P\}$  and the set  $\text{Asg}_{\subseteq}(P) \triangleq \{\chi \in \text{Asg} \mid P \subseteq \text{dom}(\chi)\}$  of assignments defined at least over  $P$ . The *satisfaction relation*  $\models$  between an assignment  $\chi$  and a QPTL formula  $\varphi$  is defined below, where  $\models_{\text{LTL}}$  is the standard LTL satisfiability and  $\chi[p \mapsto f]$  denotes the assignment that extends  $\chi$  and maps proposition  $p$  to temporal valuation  $f$ . As usual, by  $\text{free}(\varphi)$  we denote the set of propositions free in  $\varphi$ .

**DEFINITION 2 (TARSKI SEMANTICS).** *The Tarski-semantics relation  $\chi \models \varphi$  is inductively defined as follows, for all QPTL formulae  $\varphi$  and assignments  $\chi \in \text{Asg}_{\subseteq}(\text{free}(\varphi))$ .*

- (1)  $\chi \models \psi$ , if  $\chi \models_{\text{LTL}} \psi$ , whenever  $\psi$  is an LTL formula;
- (2) the semantics of Boolean connectives is defined as usual;
- (3) for all atomic propositions  $p \in AP$ :
  - (a)  $\chi \models \exists p. \phi$  if  $\chi[p \mapsto f] \models \phi$ , for some  $f \in \mathbb{N} \rightarrow \mathbb{B}$ ;
  - (b)  $\chi \models \forall p. \phi$  if  $\chi[p \mapsto f] \models \phi$ , for all  $f \in \mathbb{N} \rightarrow \mathbb{B}$ .

## 2.2 A New Semantics for QPTL

We now introduce a novel compositional semantics for QPTL that, unlike Tarski's one, will allow us to specify, later on, independence constraints among quantified propositions. The new semantics follows an approach similar to the one of Hodges [41], where a compositional semantics for IF was first proposed. Hodges' idea was to expand an assignment for the free variables to a set of assignments, a trump in his terminology (*a.k.a.* team [79]), with the intuition of capturing all possible choices made by one of the two players for its own variables in the satisfiability game underlying the game-theoretic semantics of the logic [38]. Hodges' semantics, though able to correctly capture IF, is, however, not adequate for our purposes. Indeed, by design, it is intrinsically asymmetric, treating the two players differently. More specifically, a single set of assignments only provides complete information about the choices of one of the two players and only allows to restrict the choices of the adversary. This, in turn, limits the class of games expressible in the logic to asymmetric games, where only the observation power of one player can be restricted. To also capture symmetric games, we need to get rid of this asymmetry, which requires a non-trivial generalisation of Hodges' approach. Generalisations of Hodges' semantics have been attempted in the past. For example, Kuusisto [51] advocates for an extension of trump semantics where, instead of single trump, two trumps are paired together. This allows for incorporating negation more naturally in Dependence Logic and to obtain natural duality principles. In particular, an atom is interpreted by requiring it to be satisfied by all assignments in the first trump, while none of the assignments in the second one satisfies it. Negation is interpreted by simply swapping the positions of the two teams in the pair. It should be noted that while this approach allows for recovering a form of symmetry *w.r.t.* negation, it does not provide a symmetric treatment of the restrictions on the quantifiers that we are after in the present work.

To give semantics to a QPTL formula  $\varphi$ , we proceed as follows. Similarly to Hodges, the idea is that the interpretations of the free atomic propositions correspond to the choices that the two players could make prior to the current stage of the game, *i.e.*, the stage where the formula  $\varphi$  has still to be evaluated. These possible choices can be organised on a two-level structure, *i.e.*, a set of sets of assignments, each level summarising the information about the choices a player can make in its turns. In order to evaluate the formula  $\varphi$ , then, a player chooses a set of assignment, while its opponent chooses one assignment in that set where  $\varphi$  must hold. We shall use a flag  $\alpha \in \{\exists\forall, \forall\exists\}$ , called *alternation flag*, to keep track of which player is assigned to which level of choice. If  $\alpha = \exists\forall$ , Eloise chooses the set of assignments, while Abelard chooses one of those assignments; if  $\alpha = \forall\exists$ , the dual reasoning applies. Given a flag  $\alpha \in \{\exists\forall, \forall\exists\}$ , we denote by  $\bar{\alpha}$

the dual flag, *i.e.*,  $\bar{\alpha} \in \{\exists\forall, \forall\exists\}$  with  $\bar{\alpha} \neq \alpha$ . The idea above is captured by the following notion of *hyperassignment*, namely a non-empty set of non-trivial, *i.e.*, non-empty, sets of assignments defined over an arbitrary set  $P \subseteq AP$ :

$$\text{HAsg} \triangleq \{ \mathfrak{X} \subseteq 2^{\text{Asg}(P)} \mid \emptyset \notin \mathfrak{X} \neq \emptyset \wedge P \subseteq AP \}.$$

Note that we require all the assignments contained in a hyperassignment to be defined on the same atomic propositions, though the domains of assignments in different hyperassignments may differ. By  $\text{ap}(\mathfrak{X}) \subseteq AP$  we denote the set of atomic propositions over which the hyperassignment  $\mathfrak{X}$  is defined.  $\text{HAsg}(P) \triangleq \{ \mathfrak{X} \in \text{HAsg} \mid \mathfrak{X} \subseteq 2^{\text{Asg}(P)} \}$  is the set of hyperassignments over the same set of atomic propositions  $P$ , while the set whose hyperassignments have domains that include  $P$  is  $\text{HAsg}_{\subseteq}(P) \triangleq \{ \mathfrak{X} \in \text{HAsg} \mid \mathfrak{X} \subseteq 2^{\text{Asg}_{\subseteq}(P)} \}$ .

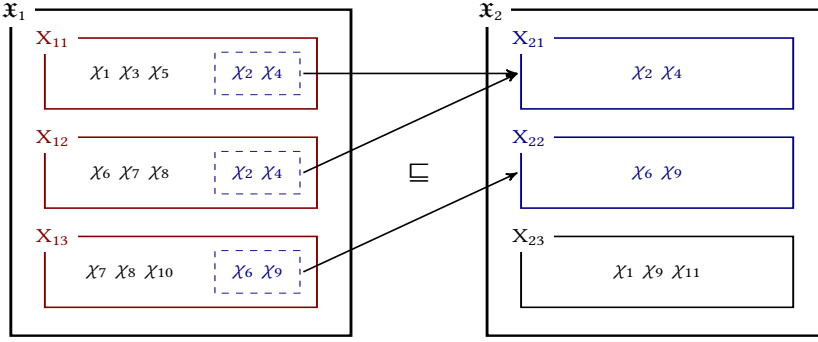

Fig. 1. The preorder  $\subseteq$  on hyperassignments: for every  $X_{1i} \in \mathfrak{X}_1$ , there is a  $X_{2j} \in \mathfrak{X}_2$  with  $X_{2j} \subseteq X_{1i}$ . More than one set in  $\mathfrak{X}_1$  may be related to the same set in  $\mathfrak{X}_2$ ; there may be sets in  $\mathfrak{X}_2$  not related to any set in  $\mathfrak{X}_1$ .

For any pair of hyperassignments  $\mathfrak{X}_1, \mathfrak{X}_2 \in \text{HAsg}$ , we write  $\mathfrak{X}_1 \subseteq \mathfrak{X}_2$  to express the fact that, for all sets of assignments  $X_1 \in \mathfrak{X}_1$ , there is a set of assignments  $X_2 \in \mathfrak{X}_2$  with  $X_2 \subseteq X_1$ . Obviously,  $\mathfrak{X}_1 \subseteq \mathfrak{X}_2$  implies  $\mathfrak{X}_1 \subseteq \mathfrak{X}_2$ , which, in turn, implies  $\text{ap}(\mathfrak{X}_1) = \text{ap}(\mathfrak{X}_2)$ . Figure 1 reports a graphical representation of the relation  $\subseteq$ . As usual, we write  $\mathfrak{X}_1 \equiv \mathfrak{X}_2$  if both  $\mathfrak{X}_1 \subseteq \mathfrak{X}_2$  and  $\mathfrak{X}_2 \subseteq \mathfrak{X}_1$  hold true. It is clear that the relation  $\subseteq$  is both reflexive and transitive, hence it is a preorder. Consequently,  $\equiv$  is an equivalence relation. In particular, we shall show (see Corollary 1) that  $\equiv$  captures the intuitive notion of equivalence between hyperassignments, in the sense that two equivalent hyperassignments *w.r.t.*  $\equiv$  do satisfy the same formulae.

Our goal is to define a semantics for QPTL by providing a satisfaction relation between a hyperassignment  $\mathfrak{X}$  and a QPTL formula  $\varphi$ , *w.r.t.* a given interpretation of the players of  $\mathfrak{X}$ , *i.e.*, *w.r.t.* an alternation flag  $\alpha \in \{\exists\forall, \forall\exists\}$ . Therefore, we shall have two satisfaction relations, namely  $\models^{\exists\forall}$  and  $\models^{\forall\exists}$ , depending on how we interpret the levels of the hyperassignment. The idea is to capture the following intuition that relates, in a natural way, to the classic Tarskian semantics. When the alternation flag  $\alpha$  is  $\exists\forall$ , then a set of assignments is chosen existentially by Eloise and all its assignments, chosen universally by Abelard, must satisfy  $\varphi$ . Conversely, when  $\alpha$  is  $\forall\exists$ , then a set of assignments is chosen universally by Abelard and at least one assignment, chosen existentially by Eloise, must satisfy  $\varphi$ . Semantically, hyperassignments are similar to *quasi-strategies* [46].

We break down the presentation of the semantics by introducing three operations: the *dualisation* swaps the role of the two players in a hyperassignment, allowing for connecting the two satisfaction relations and a symmetric treatment of quantifiers later on; the *partitioning* deals with disjunction and conjunction; finally, the *extension* directly handles quantifications.

Let us consider the dualisation operator first. The idea is that, given a hyperassignment  $\mathfrak{X}$ , the dual hyperassignment  $\overline{\mathfrak{X}}$  exchanges the role of the two players *w.r.t.*  $\mathfrak{X}$ . This means that, if Eloise is the first to choose in  $\mathfrak{X}$ , then her choice will be postponed in  $\overline{\mathfrak{X}}$  after that of Abelard. To ensure that, in exchanging the order of choice for the two players, we do not alter the semantics of the underlying game, we need to reshuffle the assignments in  $\mathfrak{X}$  so as to simulate the original dependencies between the choices of the players. To this end, we introduce the set of choice functions for  $\mathfrak{X}$  as follows, whose definition implicitly assumes the axiom of choice:

$$\text{Chc}(\mathfrak{X}) \triangleq \{\Gamma: \mathfrak{X} \rightarrow \text{Asg} \mid \forall X \in \mathfrak{X}. \Gamma(X) \in X\}.$$

$\text{Chc}(\mathfrak{X})$  contains all the functions  $\Gamma$  that, for every set of assignments  $X$  in  $\mathfrak{X}$ , pick a specific assignment  $\Gamma(X)$  in that set. Each such function simulates a possible choice of the second player of  $\mathfrak{X}$  depending on the choice of (the set of assignments chosen by) its first player. The dual hyperassignment  $\overline{\mathfrak{X}}$ , then, collects the images of the choice functions in  $\text{Chc}(\mathfrak{X})$ . We, thus, obtain a hyperassignment in which the choice order of the two players is inverted:

$$\overline{\mathfrak{X}} \triangleq \{\text{img}(\Gamma) \mid \Gamma \in \text{Chc}(\mathfrak{X})\}.$$

Consider the hyperassignment  $\mathfrak{X}$  of Figure 2, where  $X_1 = \{\chi_{11}, \chi_{12}\}$ ,  $X_2 = \{\chi_{21}, \chi_{22}\}$ , and  $X_3 = \{\chi_3\}$ . Every set of assignments in  $\overline{\mathfrak{X}}$  is obtained as the image of one of the four choice functions  $\Gamma_i \in \text{Chc}(\mathfrak{X})$ , each choosing exactly one assignment from  $X_1$ , one from  $X_2$ , and one from  $X_3$ . Intuitively, in  $\mathfrak{X}$  the strategy of the first player, say Eloise, can only choose the colour of the final assignments (either red for  $X_1$ , blue for  $X_2$ , or green for  $X_3$ ), while the one for Abelard decides which assignment of each colour will be picked. After dualisation, the two players exchange the order in which they choose. Therefore, Abelard, starting first in  $\overline{\mathfrak{X}}$ , will select one of the four choice functions, which picks an assignment for each colour. Eloise, choosing second, by using her strategy that selects the colour will give the final assignment. In other words, the original strategies of the players encoded in the hyperassignment, as well as their dependencies, are preserved, regardless of the swap of their role in the dual hyperassignment.

$$\mathfrak{X} = \left\{ \begin{array}{l} X_1 = \{\chi_{11}, \chi_{12}\}, \\ X_2 = \{\chi_{21}, \chi_{22}\}, \\ X_3 = \{\chi_3\} \end{array} \right\} \quad \overline{\mathfrak{X}} = \left\{ \begin{array}{l} \text{img}(\Gamma_1) = \{\chi_{11}, \chi_{21}, \chi_3\}, \\ \text{img}(\Gamma_2) = \{\chi_{11}, \chi_{22}, \chi_3\}, \\ \text{img}(\Gamma_3) = \{\chi_{12}, \chi_{21}, \chi_3\}, \\ \text{img}(\Gamma_4) = \{\chi_{12}, \chi_{22}, \chi_3\} \end{array} \right\}$$

Fig. 2. The dualisation of an hyperassignment.

The following proposition ensures that the dualisation operator enjoys an *involution property*, similarly to the Boolean negation: by applying the dualisation twice, we obtain a hyperassignment equivalent to the original one.

**Proposition 1.**  $\mathfrak{X} \subseteq \overline{\overline{\mathfrak{X}}}$  and  $\mathfrak{X} \equiv \overline{\overline{\mathfrak{X}}}$ , for all  $\mathfrak{X} \in \text{HAsg}$ .

Note that there is a clear analogy between the structure of hyperassignments with alternation flag  $\exists\forall$  (*resp.*,  $\forall\exists$ ) and the structure of DNF (*resp.*, CNF) formulae, where the dualisation swaps between two equivalent forms. The following lemma formally states that the dualisation swaps the role of the two players while still preserving the original dependencies among their choices.

**Lemma 1** (Dualization). *The following equivalences hold true, for all QPTL formulae  $\varphi$  and hyperassignments  $\mathfrak{X} \in \text{HAsg}_{\subseteq}(\text{free}(\varphi))$ .*

(1) *Statements 1a and 1b are equivalent:*

- (a) there exists a set of assignments  $X \in \mathfrak{X}$  such that  $\chi \models \varphi$ , for all assignments  $\chi \in X$ ;
  - (b) for all sets of assignments  $X \in \overline{\mathfrak{X}}$ , it holds that  $\chi \models \varphi$ , for some assignment  $\chi \in X$ .
- (2) Statements 2a and 2b are equivalent:
- (a) for all sets of assignments  $X \in \mathfrak{X}$ , it holds that  $\chi \models \varphi$ , for some assignment  $\chi \in X$ ;
  - (b) there exists a set of assignments  $X \in \overline{\mathfrak{X}}$  such that  $\chi \models \varphi$ , for all assignments  $\chi \in X$ .

The *partition operator* decomposes hyperassignments and is instrumental in capturing the semantics of Boolean connectives. Given a hyperassignment  $\mathfrak{X}$ , the following set

$$\text{par}(\mathfrak{X}) \triangleq \{(\mathfrak{X}_1, \mathfrak{X}_2) \in 2^{\mathfrak{X}} \times 2^{\mathfrak{X}} \mid \mathfrak{X}_1 \uplus \mathfrak{X}_2 = \mathfrak{X}\}$$

collects all the possible partitions of  $\mathfrak{X}$  into two disjoint parts, where  $\uplus$  denotes the disjoint-union operator. Assume that the two players of  $\mathfrak{X}$  are interpreted according to the alternation flag  $\forall\exists$ : Abelard chooses first and Eloise chooses second. The game-theoretic interpretation of the disjunction requires Eloise to choose one of two disjuncts to be proven true. In our setting, then, in order to satisfy  $\varphi_1 \vee \varphi_2$ , Eloise has to show that, for each set of assignments chosen by Abelard, she has a way to select one of the disjuncts  $\varphi_i$  in such a way that  $\varphi_i$  is satisfied by some assignment in that set. This selection is summarised by one of the pairs  $(\mathfrak{X}_1, \mathfrak{X}_2)$  in  $\text{par}(\mathfrak{X})$ , where  $\mathfrak{X}_i$  collects the sets of assignments for which the  $i$ -th disjunct is selected, with  $i \in \{1, 2\}$ . A similar argument, with the role of the two players reversed and switching the quantifications throughout, leads to a dual interpretation for conjunction, where it is Abelard who chooses one of the two conjuncts to be proven false. Observe that  $(\mathfrak{X}_1, \mathfrak{X}_2)$  might not be a pair of hyperassignments, as one of them could be empty. This case is, however, properly taken care of by the semantics rules of the connectives. The above intuition is made precise by the following lemma.

**Lemma 2** (Boolean Connectives). *The following equivalences hold true, for all QPTL formulae  $\varphi_1$  and  $\varphi_2$  and hyperassignments  $\mathfrak{X} \in \text{HAsg}_{\subseteq}(\mathbb{P})$ , with  $\mathbb{P} \triangleq \text{free}(\varphi_1) \cup \text{free}(\varphi_2)$ .*

- (1) Statements 1a and 1b are equivalent:
  - (a) there exists a set of assignments  $X \in \mathfrak{X}$  such that  $\chi \models \varphi_1 \wedge \varphi_2$ , for all assignments  $\chi \in X$ ;
  - (b) for each bipartition  $(\mathfrak{X}_1, \mathfrak{X}_2) \in \text{par}(\mathfrak{X})$  of  $\mathfrak{X}$ , there exist an index  $i \in \{1, 2\}$  and a set of assignments  $X \in \mathfrak{X}_i$  such that  $\chi \models \varphi_i$ , for all assignments  $\chi \in X$ .
- (2) Statements 2a and 2b are equivalent:
  - (a) for all sets of assignments  $X \in \mathfrak{X}$ , it holds that  $\chi \models \varphi_1 \vee \varphi_2$ , for some assignment  $\chi \in X$ ;
  - (b) there exists a bipartition  $(\mathfrak{X}_1, \mathfrak{X}_2) \in \text{par}(\mathfrak{X})$  of  $\mathfrak{X}$  such that, for all indexes  $i \in \{1, 2\}$  and sets of assignments  $X \in \mathfrak{X}_i$ , it holds that  $\chi \models \varphi_i$ , for some  $\chi \in X$ .

Quantifications are taken care of by the *extension operator*. Let  $\text{Fnc}(\mathbb{P}) \triangleq \text{Asg}(\mathbb{P}) \rightarrow (\mathbb{N} \rightarrow \mathbb{B})$  be the set of *functors* that maps assignments over  $\mathbb{P}$  to temporal valuations. Essentially, these objects play the role of Skolem functions in the non-compositional semantics. The *extension of an assignment*  $\chi \in \text{Asg}(\mathbb{P})$  w.r.t. a functor  $F \in \text{Fnc}(\mathbb{P})$  for an atomic proposition  $p \in \text{AP}$  is defined as  $\text{ext}(\chi, F, p) \triangleq \chi[p \mapsto F(\chi)]$ , which extends  $\chi$  with  $p$  by assigning to it the value  $F(\chi)$  prescribed by the functor  $F$ . The *extension operation* can then be lifted to sets of assignments  $X \subseteq \text{Asg}(\mathbb{P})$  in the obvious way, i.e., we set  $\text{ext}(X, F, p) \triangleq \{\text{ext}(\chi, F, p) \mid \chi \in X\}$ . This operation embeds into  $X$  the entire player strategy encoded by  $F$ . Finally, the *extension of a hyperassignment*  $\mathfrak{X} \in \text{HAsg}(\mathbb{P})$  with  $p$  is simply the set of extensions with  $p$  of all its sets of assignments w.r.t. all possible functors over the atomic propositions of  $\mathfrak{X}$ :

$$\text{ext}(\mathfrak{X}, p) \triangleq \{\text{ext}(X, F, p) \mid X \in \mathfrak{X}, F \in \text{Fnc}(\text{ap}(\mathfrak{X}))\}.$$

Intuitively, this operation embeds into  $\mathfrak{X}$  all possible strategies, each one encoded by a functors  $F$  in  $\text{Fnc}(\text{ap}(\mathfrak{X}))$ , for choosing the value of  $p$  at each time instant. The following lemma states that the



extension operator provides an adequate semantics for quantifications, where statement 1 considers Eloise's choices, when the player interpretation of the hyperassignment is  $\exists\forall$ , and statement 2 takes care of Abelard's choices, when the player interpretation is  $\forall\exists$ .

**Lemma 3** (Hyperassignment Extensions). *The following equivalences hold true, for all QPTL formulae  $\varphi$ , atomic propositions  $p \in AP$ , and hyperassignments  $\mathfrak{X} \in \text{HAsg}_{\subseteq}(\text{free}(\varphi) \setminus \{p\})$ .*

- (1) *Statements 1a and 1b are equivalent:*
  - (a) *there exists a set of assignments  $X \in \mathfrak{X}$  such that  $\chi \models \exists p. \varphi$ , for all assignments  $\chi \in X$ ;*
  - (b) *there exists a set of assignments  $X \in \text{ext}(\mathfrak{X}, p)$  such that  $\chi \models \varphi$ , for all assignments  $\chi \in X$ .*
- (2) *Statements 2a and 2b are equivalent:*
  - (a) *for all sets of assignments  $X \in \mathfrak{X}$ , it holds that  $\chi \models \forall p. \varphi$ , for some assignment  $\chi \in X$ ;*
  - (b) *for all sets of assignments  $X \in \text{ext}(\mathfrak{X}, p)$ , it holds that  $\chi \models \varphi$ , for some assignment  $\chi \in X$ .*

We can finally introduce the semantics for QPTL based on the novel notion of hyperassignment.

**DEFINITION 3** (ALTERNATING HODGES SEMANTICS). *The alternating-Hodges-semantics relation  $\mathfrak{X} \models^{\alpha} \varphi$  is inductively defined as follows, for all QPTL formulae  $\varphi$ , hyperassignments  $\mathfrak{X} \in \text{HAsg}_{\subseteq}(\text{free}(\varphi))$ , and alternation flags  $\alpha \in \{\exists\forall, \forall\exists\}$ .*

- (1) *whenever  $\psi$  is an LTL formula:*
  - (a)  $\mathfrak{X} \models^{\exists\forall} \psi$  *if there exists a set of assignments  $X \in \mathfrak{X}$  such that, for each assignment  $\chi \in X$ , it holds that  $\chi \models_{\text{LTL}} \psi$ ;*
  - (b)  $\mathfrak{X} \models^{\forall\exists} \psi$  *if, for all sets of assignments  $X \in \mathfrak{X}$ , there is an assignment  $\chi \in X$  such that  $\chi \models_{\text{LTL}} \psi$ ;*
- (2)  $\mathfrak{X} \models^{\alpha} \neg\phi$  *if  $\mathfrak{X} \not\models^{\bar{\alpha}} \phi$ , i.e., it is not the case that  $\mathfrak{X} \models^{\bar{\alpha}} \phi$ ;*
- (3) (a)  $\mathfrak{X} \models^{\exists\forall} \phi_1 \wedge \phi_2$  *if, for each bipartition  $(\mathfrak{X}_1, \mathfrak{X}_2) \in \text{par}(\mathfrak{X})$  of  $\mathfrak{X}$ , it holds that  $\mathfrak{X}_1 \neq \emptyset$  and  $\mathfrak{X}_1 \models^{\exists\forall} \phi_1$  or  $\mathfrak{X}_2 \neq \emptyset$  and  $\mathfrak{X}_2 \models^{\exists\forall} \phi_2$ ;*  
 (b)  $\mathfrak{X} \models^{\forall\exists} \phi_1 \wedge \phi_2$  *if  $\bar{\mathfrak{X}} \models^{\exists\forall} \phi_1 \wedge \phi_2$ ;*
- (4) (a)  $\mathfrak{X} \models^{\forall\exists} \phi_1 \vee \phi_2$  *if there exists a bipartition  $(\mathfrak{X}_1, \mathfrak{X}_2) \in \text{par}(\mathfrak{X})$  of  $\mathfrak{X}$  such that if  $\mathfrak{X}_1 \neq \emptyset$  then  $\mathfrak{X}_1 \models^{\forall\exists} \phi_1$  and if  $\mathfrak{X}_2 \neq \emptyset$  then  $\mathfrak{X}_2 \models^{\forall\exists} \phi_2$ ;*  
 (b)  $\mathfrak{X} \models^{\exists\forall} \phi_1 \vee \phi_2$  *if  $\bar{\mathfrak{X}} \models^{\forall\exists} \phi_1 \vee \phi_2$ ;*
- (5) *for all atomic propositions  $p \in AP$ :*
  - (a)  $\mathfrak{X} \models^{\exists\forall} \exists p. \phi$  *if  $\text{ext}(\mathfrak{X}, p) \models^{\exists\forall} \phi$ ;*
  - (b)  $\mathfrak{X} \models^{\forall\exists} \exists p. \phi$  *if  $\bar{\mathfrak{X}} \models^{\exists\forall} \exists p. \phi$ ;*
- (6) *for all atomic propositions  $p \in AP$ :*
  - (a)  $\mathfrak{X} \models^{\forall\exists} \forall p. \phi$  *if  $\text{ext}(\mathfrak{X}, p) \models^{\forall\exists} \phi$ ;*
  - (b)  $\mathfrak{X} \models^{\exists\forall} \forall p. \phi$  *if  $\bar{\mathfrak{X}} \models^{\forall\exists} \forall p. \phi$ .*

The base case (Item 1) for LTL formulae  $\psi$  simply formalises the intuition about satisfaction relative to the alternation flag: if  $\alpha = \exists\forall$ , there exists a set of assignments whose elements satisfy  $\psi$  in the Tarski sense; the dual applies when  $\alpha = \forall\exists$ . Negation, in accordance with the classic game-theoretic interpretation, is dealt with by simply exchanging the player interpretation of the hyperassignment (Item 2). Observe that, from this semantic condition, it immediately follows that either  $\mathfrak{X} \models^{\alpha} \varphi$  or  $\mathfrak{X} \models^{\bar{\alpha}} \neg\varphi$ . In other words, the semantics does not allow for formulae with an undetermined truth value. The semantics of the remaining Boolean connectives (Items 3a and 4a) and quantifiers (Items 5a and 6a) is a direct application of Lemmata 2 and 3. Observe that swapping between  $\models^{\exists\forall}$  and  $\models^{\forall\exists}$  (Items 3b, 4b, 5b and 6b) is done according to Lemma 1 and it represents the fundamental point where our approach departs from Hodges' semantics [41, 42]. The above three lemmata also imply the following theorem (whose proof is provided in Electronic Appendix A),

which formalises an *adequacy principle* that naturally reduces the two satisfiability relations of the new semantics to the classic Tarskian satisfaction.

**Theorem 1** (Semantics Adequacy). *For all QPTL formulae  $\varphi$  and hyperassignments  $\mathfrak{X} \in \text{HAsg}_{\subseteq}(\text{free}(\varphi))$ :*

- (1)  $\mathfrak{X} \models^{\exists\forall} \varphi$  iff there exists a set of assignments  $X \in \mathfrak{X}$  such that  $\chi \models \varphi$ , for all assignments  $\chi \in X$ ;
- (2)  $\mathfrak{X} \models^{\forall\exists} \varphi$  iff, for all sets of assignments  $X \in \mathfrak{X}$ , it holds that  $\chi \models \varphi$ , for some assignment  $\chi \in X$ .

From now on, as usual, we assume the Boolean connectives  $\rightarrow$  and  $\leftrightarrow$  to be defined as  $\varphi_1 \rightarrow \varphi_2 \triangleq \neg\varphi_1 \vee \varphi_2$  and  $\varphi_1 \leftrightarrow \varphi_2 \triangleq (\varphi_1 \wedge \varphi_2) \vee (\neg\varphi_1 \wedge \neg\varphi_2)$ . The following two examples may help familiarise with the new semantics.

**Example 1.** *Let us consider the QPTL sentence  $\varphi \triangleq \forall p. (\psi_p \rightarrow \exists q. (\psi_q \wedge (q \leftrightarrow Xp)))$ , with  $\psi_p \triangleq \neg p \wedge X(Gp \vee G\neg p)$  and  $\psi_q \triangleq Gq \vee G\neg q$ . The sentence  $\varphi$  can be viewed as the description of a very simple game with two players, Abelard and Eloise. Abelard can only choose a truth value for  $p$  that will hold constant at any time instant except for time 0, where it is false regardless of his choice, in accordance with  $\psi_p$ . Eloise, instead, chooses a truth value for  $q$  that will hold constant from time 0 onward, as dictated by  $\psi_q$ . The LTL formula  $q \leftrightarrow Xp$  encodes the game objective, requiring that the truth value of  $p$  at time 1 matches that of  $q$  at time 0. Sentence  $\varphi$ , then, asks whether Eloise can respond with one of her legal moves to every legal move by Abelard so that the objective is always met. By applying the semantic rules given in Definition 3, we may obtain the following chain of semantic conditions:*

- (1)  $\{\{\emptyset\}\} \models^{\forall\exists} \varphi$ ;
- (2)  $\{\{\chi_p\}, \{\chi_{\bar{p}}\}, \dots\} \models^{\forall\exists} \psi_p \rightarrow \exists q. (\psi_q \wedge (q \leftrightarrow Xp))$ ;
- (3)  $\{\dots\} \models^{\forall\exists} \neg\psi_p$  and  $\{\{\chi_p\}, \{\chi_{\bar{p}}\}\} \models^{\forall\exists} \exists q. (\psi_q \wedge (q \leftrightarrow Xp))$ ;
- (4)  $\{\{\chi_p, \chi_{\bar{p}}\}\} \models^{\exists\forall} \exists q. (\psi_q \wedge (q \leftrightarrow Xp))$ ;
- (5)  $\{\{\chi_{pq}, \chi_{\bar{p}q}\}, \{\chi_{p\bar{q}}, \chi_{\bar{p}\bar{q}}\}, \{\chi_{p\bar{q}}, \chi_{\bar{p}q}\}, \{\chi_{p\bar{q}}, \chi_{\bar{p}\bar{q}}\}, \dots\} \models^{\exists\forall} \psi_q \wedge (q \leftrightarrow Xp)$ .

where Step 3, according to the semantics of disjunction, derives from one of the possible, existentially quantified, partitioning of the hyperassignment in Step 2. The steps above go as follows. Being  $\varphi$  a sentence, it is satisfiable iff Step 1 holds true. By Rule 6a of Definition 3 on universal quantifications, we derive Step 2, where  $\chi_p \triangleq \{p \mapsto \perp^{\top\omega}\}$  and  $\chi_{\bar{p}} \triangleq \{p \mapsto \perp^{\omega}\}$  are the only two assignments satisfying the precondition  $\psi_p$ . The first assignment is obtained by extending  $\emptyset$  by means of the constant functor  $F_{\perp\top}$  which returns false at time 0 and true at every future instant, i.e.,  $\chi_p = \text{ext}(\emptyset, F_{\perp\top}, p)$ . Similarly, the second one is obtained by the constant functor  $F_{\perp}$  returning false at any time. The assignments obtained by the uncountably many remaining functors are summarised by the ellipsis. Applying Rule 4a, one can choose to split the hyperassignment into the following two parts:  $\{\dots\}$  containing all the singleton sets of those assignments violating  $\psi_p$  and its complement  $\{\{\chi_p\}, \{\chi_{\bar{p}}\}\}$ . On the first hyperassignment we need to check  $\neg\psi_p$ , while on the second one the remaining part of the formula, as stated in Step 3. Since  $\{\dots\} \models^{\forall\exists} \neg\psi_p$  holds by construction, Rule 5b applied to the second part leads to Step 4, where we use the equality  $\{\{\chi_p, \chi_{\bar{p}}\}\} = \overline{\{\{\chi_p\}, \{\chi_{\bar{p}}\}\}}$ . Rule 5a on existential quantifications allows, then, to derive Step 5, where  $\chi_{bq} \triangleq \chi_b[q \mapsto \top^{\omega}]$  and  $\chi_{b\bar{q}} \triangleq \chi_b[q \mapsto \perp^{\omega}]$ , with  $b \in \{p, \bar{p}\}$ . The relevant sets of assignments in the hyperassignment at Step 5 are obtained as follows:

- (a)  $\{\chi_{pq}, \chi_{\bar{p}q}\} = \text{ext}\left(\{\chi_p, \chi_{\bar{p}}\}, F_{\top}, q\right)$ , where  $F_{\top}$  is the constant functor returning true at every time;
- (b)  $\{\chi_{p\bar{q}}, \chi_{\bar{p}\bar{q}}\} = \text{ext}\left(\{\chi_p, \chi_{\bar{p}}\}, F_p, q\right)$ , where  $F_p(\chi)$  returns at time  $i$  the value of  $p$  in  $\chi$  at  $i+1$ ;
- (c)  $\{\chi_{p\bar{q}}, \chi_{\bar{p}q}\} = \text{ext}\left(\{\chi_p, \chi_{\bar{p}}\}, F_{\bar{p}}, q\right)$ , where  $F_{\bar{p}}(\chi)$  returns at time  $i$  the dual value of  $p$  in  $\chi$  at  $i+1$ ;
- (d)  $\{\chi_{p\bar{q}}, \chi_{\bar{p}\bar{q}}\} = \text{ext}\left(\{\chi_p, \chi_{\bar{p}}\}, F_{\perp}, q\right)$ , where  $F_{\perp}$  is the constant functor returning false at every time.

At this point, since  $\psi_q \wedge (q \leftrightarrow Xp)$  is an LTL formula, Rule 1 of Definition 3 can be applied, thus asking for a set of assignments containing only assignments that make  $\psi_q \wedge (q \leftrightarrow Xp)$  true. Both assignments in the doubleton  $\{\chi_{pq}, \chi_{\overline{p}q}\}$  satisfy the LTL formula  $\psi_q \wedge (q \leftrightarrow Xp)$ , which implies that  $\varphi$  is satisfiable, witnessing Eloise's win.

**Example 2.** The simple game in the previous example can equivalently be expressed by the following prenex-form sentence  $\varphi' \triangleq \forall p. \exists q. (\psi_p \rightarrow (\psi_q \wedge (q \leftrightarrow Xp)))$ , where an LTL formula is preceded by a quantifier prefix. The semantic steps here are slightly different and somewhat simpler, since we assume the classic semantics for temporal and Boolean operators within a pure LTL formula. In this case, by applying the semantics, one would obtain the following chain of conditions:

- (1)  $\{\{\emptyset\}\} \models^{\forall\exists} \varphi'$ ;
- (2)  $\{\{\chi_p\}, \{\chi_{\overline{p}}\}, \dots\} \models^{\forall\exists} \exists q. (\psi_p \rightarrow (\psi_q \wedge (q \leftrightarrow Xp)))$ ;
- (3)  $\{\{\chi_p, \chi_{\overline{p}}\}, \dots\} \models^{\exists\forall} \exists q. (\psi_p \rightarrow (\psi_q \wedge (q \leftrightarrow Xp)))$ ;
- (4)  $\{\{\chi_{pq}, \chi_{\overline{p}q}, \dots\}, \{\chi_{p\overline{q}}, \chi_{\overline{p}\overline{q}}, \dots\}, \{\chi_{p\overline{q}}, \chi_{\overline{p}q}, \dots\}, \{\chi_{p\overline{q}}, \chi_{\overline{p}\overline{q}}, \dots\}, \dots\} \models^{\exists\forall} \psi_p \rightarrow (\psi_q \wedge (q \leftrightarrow Xp))$ .

As in Example 1,  $\varphi'$  is satisfiable iff Step 1 holds true and Step 2 is obtained by applying Rule 6a of Definition 3 on universal quantifications, where the ellipsis in the hyperassignment is in place of all those singletons of assignments not satisfying  $\psi_p$ . Steps 3 and 4 are due to Rules 5b and 5a on existential quantifications. In particular, the innermost ellipses in the hyperassignment at Step 4 are again in place of assignments not satisfying  $\psi_p$ , while the outermost ellipsis stands for all those sets of assignments not satisfying  $\psi_q$ . Finally, it is clear that  $\{\chi_{pq}, \chi_{\overline{p}q}, \dots\}$  is the only set of assignments universally satisfying the LTL formula  $\psi_p \rightarrow (\psi_q \wedge (q \leftrightarrow Xp))$ , as all the other sets have at least one assignment satisfying  $\psi_p$ , but falsifying  $\psi_q$  or  $q \leftrightarrow Xp$ .

### 3 GOOD-FOR-GAME QPTL

The semantic framework introduced in the previous section allows us to encode behavioural independence constraints among the quantified variables of QPTL. We thus obtain the logic GFG-QPTL, an extension of QPTL able to express the behavioralness of quantifications over temporal valuations.

#### 3.1 Adding Behavioural Dependencies to QPTL

Given a set of assignments  $\text{Asg}(P)$  over some  $P \subseteq AP$ , a *behavioural quantification w.r.t.* a proposition  $p \in P$  should choose, for each assignment  $\chi \in \text{Asg}(P)$ , a temporal valuation  $f: \mathbb{N} \rightarrow \mathbb{B}$  in such a way that, intuitively, at each instant of time  $k \in \mathbb{N}$ , the value  $f(k)$  of  $f$  at  $k$  only depends on the values  $\chi(p)(t)$  of the temporal valuation  $\chi(p)$  at the instants of time  $t \leq k$ ; this means that  $f(k)$  is independent of the values  $\chi(p)(t)$  at any future instant  $t > k$ . To be more precise, consider two assignments  $\chi_1, \chi_2 \in \text{Asg}(P)$  that may differ only on  $p$  strictly after  $k$ . Then, the functor  $F \in \text{Fnc}(P)$  interpreting a quantification behavioural w.r.t.  $p$  must return the same value at  $k$  as a reply to both  $\chi_1$  and  $\chi_2$ , i.e.,  $F(\chi_1)(k) = F(\chi_2)(k)$ ; in other words,  $F(\chi)(k)$  cannot exploit the knowledge of the values  $\chi(p)(t)$ , with  $t > k$ . An analogous concept has been introduced in SL [59]. A stronger notion of behavioralness, similar to one reported by Gardy et al. [23], requires the functor  $F$  to satisfy the above equality when  $\chi_1$  and  $\chi_2$  only (possibly) differ on  $p$  for  $t \geq k$  and leads to the concept of *strongly behavioural quantification*. In game-theoretic terms, the interpretation of a *behavioural quantifier w.r.t. p* requires the corresponding player to choose the value of a proposition at each round only based on the choices for  $p$  made by the adversary up to that round. For a *strongly behavioural quantifier*, instead, the adversary keeps its choice for  $p$  at the current round hidden and the player can only access the choices made for  $p$  at previous rounds. Definitions 4 and 5 formalise these fundamental concepts.

**DEFINITION 4 (ASSIGNMENT DISTINGUISHABILITY).** Let  $\chi_1, \chi_2 \in \text{Asg}(\mathbb{P})$  be two assignments over some set  $\mathbb{P} \subseteq \text{AP}$  of propositions,  $p \in \mathbb{P}$  one of these propositions, and  $k \in \mathbb{N}$  a number. Then,  $\chi_1$  and  $\chi_2$  are  $(p, k)$ -strict distinguishable (resp.,  $(p, k)$ -distinguishable), in symbols  $\chi_1 \approx_p^{>k} \chi_2$  (resp.,  $\chi_1 \approx_p^{\geq k} \chi_2$ ), if the following properties hold:

- (1)  $\chi_1(q) = \chi_2(q)$ , for all atomic propositions  $q \in \mathbb{P}$  with  $q \neq p$ ;
- (2)  $\chi_1(p)(t) = \chi_2(p)(t)$ , for all time instants  $t \leq k$  (resp.,  $t < k$ ).

The notion of  $(p, k)$ -strict distinguishability (resp.,  $(p, k)$ -distinguishability) allows us to identify all the assignments that can only differ on the proposition  $p$  at some time instant  $t > k$  (resp.,  $t \geq k$ ). Indeed,  $\approx_p^{>k}$  (resp.,  $\approx_p^{\geq k}$ ) is an equivalence relation on  $\text{Asg}(\mathbb{P})$ , whose equivalence classes identify those assignments precisely. A behavioural (resp., strongly-behavioural) functor must reply at time  $k$  uniformly to all  $\approx_p^{>k}$ -equivalent (resp.,  $\approx_p^{\geq k}$ -equivalent) assignments.

**DEFINITION 5 (BEHAVIOURAL FUNCTOR).** Let  $F \in \text{Fnc}(\mathbb{P})$  be a functor over some set  $\mathbb{P} \subseteq \text{AP}$  of propositions and  $p \in \mathbb{P}$  one of these propositions. Then,  $F$  is behavioural (resp., strongly behavioural) w.r.t.  $p$  if  $F(\chi_1)(k) = F(\chi_2)(k)$ , for all numbers  $k \in \mathbb{N}$  and pairs of  $\approx_p^{>k}$ -equivalent (resp.,  $\approx_p^{\geq k}$ -equivalent) assignments  $\chi_1, \chi_2 \in \text{Asg}(\mathbb{P})$ .

	0	1	2	3	4	5	
$\chi_1 = \{ p: $	T	⊥	⊥	T	⊥	T	⋯
$\chi_2 = \{ p: $	T	⊥	⊥	T	T	⊥	⋯
$F_A(\chi_1) =$	⊥	⊥	T	⊥	T	⊥	⋯
$F_A(\chi_2) =$	⊥	⊥	T	T	⊥	T	⋯
$F_B(\chi_1) =$	⊥	T	T	⊥	T	⊥	⋯
$F_B(\chi_2) =$	⊥	T	T	⊥	⊥	T	⋯
$F_S(\chi_1) =$	T	T	⊥	⊥	T	⊥	⋯
$F_S(\chi_2) =$	T	T	⊥	⊥	T	T	⋯

Fig. 3. Two  $\approx_p^{>3}$  (resp.,  $\approx_p^{\geq 4}$ )-equivalent assignments with one non-behavioural ( $F_A$ ), one behavioural ( $F_B$ ) and one strongly-behavioural ( $F_S$ ) functor.

**Example 3.** Let  $\chi_1$  and  $\chi_2$  be two assignments over the singleton  $\{p\}$  defined as reported in Figure 3. It is clear that  $\chi_1 \approx_p^{>3} \chi_2$ , but  $\chi_1 \not\approx_p^{\geq 4} \chi_2$ , and so  $\chi_1 \approx_p^{\geq 4} \chi_2$ , but  $\chi_1 \not\approx_p^{\geq 5} \chi_2$ . Also, consider the three functors  $F_A, F_B, F_S \in \text{Fnc}(\{p\})$  defined as follows, for all hyperassignments  $\mathfrak{X} \in \text{Asg}(\{p\})$  and time instants  $t \in \mathbb{N}$ :  $F_A(\mathfrak{X})(t) \triangleq \mathfrak{X}(p)(t+1)$ ;  $F_B(\mathfrak{X})(t) \triangleq \mathfrak{X}(p)(t)$ ;  $F_S(\mathfrak{X})(t) \triangleq \top$ , if  $t = 0$ , and  $F_S(\mathfrak{X})(t) \triangleq \mathfrak{X}(p)(t-1)$ , otherwise. It is immediate to see that  $F_B$  is behavioural, while  $F_S$  is strongly behavioural. However,  $F_A$  does not enjoy any behavioural property, being defined as a future-dependent functor. Indeed,  $F_A(\chi_1)(3) \neq F_A(\chi_2)(3)$ , even though  $\chi_1 \approx_p^{>3} \chi_2$ .

To capture in the logic the behavioural constraints on the functors, we extend QPTL with additional decorations for the quantifiers that express behavioural dependencies among the propositions involved. The result is a new logic, called *Good-for-Games* QPTL, able to express in a natural way game-theoretic concepts of Boolean games.

**DEFINITION 6 (GFG-QPTL SYNTAX).** Good-for-Games QPTL (GFG-QPTL) is the set of formulae built according to the following context-free grammar, where  $\psi \in \text{LTL}$ ,  $p \in \text{AP}$ , and  $\mathbb{P}_B, \mathbb{P}_S \subseteq \text{AP}$ :

$$\varphi ::= \psi \mid \neg\varphi \mid \varphi \wedge \varphi \mid \varphi \vee \varphi \mid \exists p: \Theta. \varphi \mid \forall p: \Theta. \varphi; \quad \Theta ::= \langle \mathbb{P}_B, \mathbb{P}_S \rangle.$$

A propositional quantifier of the form  $Qp: \langle \begin{smallmatrix} B:P_B \\ S:P_S \end{smallmatrix} \rangle$ , with  $Q \in \{\exists, \forall\}$ , explicitly expresses a  $Q$ -quantification over  $p$ , *i.e.*, a choice of a functor to interpret  $p$  that is also behavioural *w.r.t.* all the propositions in  $P_B$  and strongly-behavioural *w.r.t.* those in  $P_S$ .

To ease the notation, we may write  $Q^\Theta p. \varphi$  instead of  $Qp: \Theta. \varphi$ , write  $\langle B : P_B \rangle$  and  $\langle S : P_S \rangle$  for  $\langle \begin{smallmatrix} B:P_B \\ S:\emptyset \end{smallmatrix} \rangle$  and  $\langle \begin{smallmatrix} B:\emptyset \\ S:P_S \end{smallmatrix} \rangle$ , respectively, and  $B$  and  $S$  instead of  $\langle B : AP \rangle$  and  $\langle S : AP \rangle$ . We also omit the quantifier specification  $\langle \begin{smallmatrix} B:\emptyset \\ S:\emptyset \end{smallmatrix} \rangle$ , using  $Qp. \varphi$  to denote  $Qp: \langle \begin{smallmatrix} B:\emptyset \\ S:\emptyset \end{smallmatrix} \rangle. \varphi$ . Observe that the quantifier  $Qp$ , which is not restricted, is equivalent to the corresponding QPTL quantifier. Finally, we may drop the curly brackets for the sets  $P_B$  and  $P_S$  and write  $\langle B : p, q \rangle$  instead of  $\langle B : \{p, q\} \rangle$ .

We say that a GFG-QPTL formula is *behavioural* (*resp.*, *strongly-behavioural*) if it is in prenex form, its quantifier prefix does not contain duplicated variables (*i.e.*, every variable is quantified over at most once), and all its quantifier specifications are equal to  $B$  (*resp.*,  $S$ ). We call *behavioral* GFG-QPTL the syntactic fragment of GFG-QPTL that considers behavioural GFG-QPTL formulae only. We denote by  $Q_n$  (*resp.*,  $Q_{n_B}$ ) the set of (*resp.*, behavioural) quantifier prefixes and by  $\Theta$  the set of quantifier specifications.

Given assignments  $\chi_1, \chi_2 \in \text{Asg}(P)$ , we write  $\chi_1 \sim_\Theta^k \chi_2$ , for some  $\Theta = \langle \begin{smallmatrix} B:P_B \\ S:P_S \end{smallmatrix} \rangle \in \Theta$  and  $k \in \mathbb{N}$ , if one of the following conditions holds: (1)  $\chi_1 = \chi_2$ ; (2)  $\chi_1 \approx_p^{>k} \chi_2$ , for some  $p \in P_B$ ; (3)  $\chi_1 \approx_p^{\geq k} \chi_2$ , for some  $p \in P_S$ . We use  $\approx_\Theta^k$  to denote the transitive closure of the reflexive and symmetric relation  $\sim_\Theta^k$ .

**Proposition 2.** *Let  $P \subseteq AP$  be a set of atomic propositions,  $\chi_1, \chi_2 \in \text{Asg}(P)$  two assignments,  $\Theta \in \Theta$  a quantifier specification, and  $k \in \mathbb{N}$  a time instant. Then,  $\chi_1 \approx_\Theta^k \chi_2$  iff the following hold true:*

- (1)  $\chi_1(q) = \chi_2(q)$ , for all  $q \in P \setminus (P_B \cup P_S)$ ;
- (2)  $\chi_1(p)(t) = \chi_2(p)(t)$ , for all  $t \leq k$  and  $p \in (P_B \cap P) \setminus P_S$ ;
- (3)  $\chi_1(p)(t) = \chi_2(p)(t)$ , for all  $t < k$  and  $p \in P_S \cap P$ .

		0	1	2	3	4	5	
$\chi_1 = \left\{ \right.$	$p:$	T	⊥	⊥	T	⊥	T	⋯
	$q:$	⊥	⊥	T	T	⊥	T	⋯
$\chi_2 = \left\{ \right.$	$p:$	T	⊥	⊥	T	T	⊥	⋯
	$q:$	⊥	⊥	T	T	⊥	T	⋯
$\chi_3 = \left\{ \right.$	$p:$	T	⊥	⊥	T	T	⊥	⋯
	$q:$	⊥	⊥	T	⊥	T	T	⋯

Fig. 4. Three  $\approx_\Theta^3$ -equivalent assignments, with  $\Theta \triangleq \langle \begin{smallmatrix} B:p \\ S:q \end{smallmatrix} \rangle$ .

**Example 4.** *Consider the three assignments  $\chi_1, \chi_2$ , and  $\chi_3$  over the doubleton  $\{p, q\}$  depicted in Figure 4. It is easy to see that  $\chi_1 \approx_p^{>3} \chi_2$ , as  $\chi_1(q) = \chi_2(q)$  and the first position at which the two assignments differ on  $p$  is 4; in addition,  $\chi_2 \approx_q^{\geq 3} \chi_3$ , since  $\chi_2(p) = \chi_3(p)$  and the first position at which the two assignments differ on  $q$  is 3. Therefore, taking  $\Theta \triangleq \langle \begin{smallmatrix} B:p \\ S:q \end{smallmatrix} \rangle$ , we have  $\chi_1 \sim_\Theta^3 \chi_2 \sim_\Theta^3 \chi_3$ , which implies  $\chi_1 \approx_\Theta^3 \chi_3$ .*

Given a set of propositions  $P \subseteq AP$  and a quantifier specification  $\Theta \triangleq \langle \begin{smallmatrix} B:P_B \\ S:P_S \end{smallmatrix} \rangle \in \Theta$ , we introduce the set of  $\Theta$ -functors  $\text{Fnc}_\Theta(P) \subseteq \text{Fnc}(P)$  containing exactly those  $F \in \text{Fnc}(P)$  that are behavioural *w.r.t.* all the propositions in  $P_B \cap P$  and strongly behavioural *w.r.t.* those in  $P_S \cap P$ .

**Example 5.** *Any  $\langle \begin{smallmatrix} B:p \\ S:q \end{smallmatrix} \rangle$ -functor  $F$  replies to all assignments of Figure 4 uniformly, for all time instants between 0 and 3 included. Indeed,  $F(\chi_1)(3) = F(\chi_2)(3)$ , since  $\chi_1 \approx_p^{>3} \chi_2$ , being  $F$  behavioural *w.r.t.**

$p$ . Similarly,  $F(\chi_2)(3) = F(\chi_3)(3)$ , since  $\chi_2 \approx_q^{\geq 3} \chi_3$ , being  $F$  strongly-behavioural w.r.t.  $q$ . Hence,  $F(\chi_1)(3) = F(\chi_3)(3)$ .

The following proposition ensures that the above example highlights a general phenomenon.

**Proposition 3.** *If  $\chi_1 \approx_{\Theta}^k \chi_2$  then  $F(\chi_1)(k) = F(\chi_2)(k)$ , for all assignments  $\chi_1, \chi_2 \in \text{Asg}(\mathbb{P})$ , quantifier specifications  $\Theta \in \Theta$ , time instants  $k \in \mathbb{N}$ , and  $\Theta$ -functors  $F \in \text{Fnc}_{\Theta}(\mathbb{P})$ .*

A compositional semantics for GFG-QPTL can be obtained by extending the alternating Hodges semantics of QPTL reported in Definition 3 to account for the possible dependency constraints associated with the quantifiers. To this end, we simply need to parameterise the extension operation for hyperassignments with the corresponding specification of the behavioural dependencies:

$$\text{ext}_{\Theta}(\mathfrak{X}, p) \triangleq \{\text{ext}(X, F, p) \mid X \in \mathfrak{X}, F \in \text{Fnc}_{\Theta}(\text{ap}(\mathfrak{X}))\}.$$

**DEFINITION 7 (ALTERNATING HODGES SEMANTICS REVISITED).** *The alternating-Hodges-semantics relation  $\mathfrak{X} \models^{\alpha} \varphi$  is inductively defined as in Definition 3, for all but Items 5a and 6a that are modified, respectively, as follows, for all propositions  $p \in \text{AP}$  and quantifier specifications  $\Theta \in \Theta$ :*

$$5a') \mathfrak{X} \models^{\exists^V} \exists p: \Theta. \phi \text{ if } \text{ext}_{\Theta}(\mathfrak{X}, p) \models^{\exists^V} \phi;$$

$$6a') \mathfrak{X} \models^{\forall^{\exists}} \forall p: \Theta. \phi \text{ if } \text{ext}_{\Theta}(\mathfrak{X}, p) \models^{\forall^{\exists}} \phi.$$

Note that one could easily extend both the syntax and semantics of the quantifier specification  $\langle \text{S}_{\mathbb{P}}^{\text{B:P}_B} \rangle$  of GFG-QPTL in order to accommodate other types of (in)dependence constraints, like the ones already studied in first-order logic of incomplete information [27, 38, 41, 55, 79]. It would suffice to introduce suitable classes of functors and corresponding constructs, such as the *dependence atoms* of dependence logic, whose semantics can be easily defined via hyperassignments.

For every GFG-QPTL formula  $\varphi$  and alternation flag  $\alpha \in \{\exists^V, \forall^{\exists}\}$ , we say that  $\varphi$  is  $\alpha$ -satisfiable if there exists a hyperassignment  $\mathfrak{X} \in \text{HAsg}(\text{free}(\varphi))$  such that  $\mathfrak{X} \models^{\alpha} \varphi$ . Also,  $\varphi$   $\alpha$ -implies (resp., is  $\alpha$ -equivalent to) a GFG-QPTL formula  $\phi$ , in symbols  $\varphi \Rightarrow^{\alpha} \phi$  (resp.,  $\varphi \equiv^{\alpha} \phi$ ), whenever  $\text{free}(\varphi) = \text{free}(\phi)$  and if  $\mathfrak{X} \models^{\alpha} \varphi$  then  $\mathfrak{X} \models^{\alpha} \phi$  (resp.,  $\mathfrak{X} \models^{\alpha} \varphi$  iff  $\mathfrak{X} \models^{\alpha} \phi$ ), for all  $\mathfrak{X} \in \text{HAsg}_{\subseteq}(\text{free}(\varphi))$ . Finally, we say that  $\varphi$  is *satisfiable* if it is both  $\exists^V$ - and  $\forall^{\exists}$ -satisfiable, and write  $\varphi \Rightarrow \phi$  (resp.,  $\varphi \equiv \phi$ ) if both  $\varphi \Rightarrow^{\exists^V} \phi$  and  $\varphi \Rightarrow^{\forall^{\exists}} \phi$  (resp.,  $\varphi \equiv^{\exists^V} \phi$  and  $\varphi \equiv^{\forall^{\exists}} \phi$ ) hold.

At this point, let us consider some examples to provide insights on the expressive power of the new logic.

**Example 6.** *Let us consider again the QPTL pnf sentence  $\varphi'$  of Example 2. Obviously, Eloise cannot win the game described by that sentence following a behavioural strategy, as she would need to know at round 0 the opponent's choice for  $p$  at round 1. This is clearly reflected in the compositional semantics. Indeed, the functor  $F_p$  required to obtain the two satisfying assignments  $\chi_{pq}$  and  $\chi_{p\bar{q}}$  is clearly non-behavioural. Therefore,  $\varphi'$  is not realisable in the sense of Pnueli and Rosner [72], since the functor  $F_p$  cannot be implemented by any concrete transducer. This is confirmed by observing that if we replace the two quantifiers with their behavioural counterparts, the resulting GFG-QPTL formula  $\varphi'_B \triangleq \forall^B p. \exists^B q. (\psi_p \rightarrow (\psi_q \wedge (q \leftrightarrow Xp)))$ , is no longer satisfiable. Indeed, the only behavioural functors allowing for the satisfaction of  $\psi_q$  are  $F_{\top}$  and  $F_{\perp}$ . Therefore, semantic steps analogous to the ones shown in Example 2 applied to  $\varphi'_B$  would lead to  $\{\{\chi_{pq}, \chi_{p\bar{q}}, \dots\}, \{\chi_{p\bar{q}}, \chi_{p\bar{q}}, \dots\}, \dots\} \models^{\exists^V} \psi_p \rightarrow (\psi_q \wedge (q \leftrightarrow Xp))$ , where the sets of assignments are obtained as follows:*

- $\{\chi_{pq}, \chi_{p\bar{q}}, \dots\} = \text{ext}\left(\{\chi_p, \chi_{\bar{p}}, \dots\}, F_{\top}, q\right);$
- $\{\chi_{p\bar{q}}, \chi_{p\bar{q}}, \dots\} = \text{ext}\left(\{\chi_p, \chi_{\bar{p}}, \dots\}, F_{\perp}, q\right);$
- *the outer ellipsis  $\dots = \left\{ \text{ext}\left(\{\chi_p, \chi_{\bar{p}}, \dots\}, F, q\right) \mid F \in \text{Fnc}_B \setminus \{F_{\top}, F_{\perp}\} \right\}$  contains all the extensions of  $\{\chi_p, \chi_{\bar{p}}, \dots\}$  w.r.t. the remaining behavioural functors.*

Clearly, each set of assignments in the outer ellipsis contains no assignment satisfying  $\psi_q$ . Each such set also contains at least one assignment that does not satisfy  $\psi_p$ . As a consequence, no set in the outer ellipsis universally satisfies  $\psi_p \rightarrow (\psi_q \wedge (q \leftrightarrow \chi p))$ . Moreover, in the first set of assignments  $\{\chi_{pq}, \chi_{\bar{p}q}, \dots\}$ , the assignment  $\chi_{\bar{p}q}$  satisfies both  $\psi_p$  and  $\psi_q$ , but not  $q \leftrightarrow \chi p$ . In the second set  $\{\chi_{p\bar{q}}, \chi_{\bar{p}\bar{q}}, \dots\}$ , instead, the unsatisfying assignment is  $\chi_{p\bar{q}}$ , for the same reason. This shows that  $\phi'_B$  is unsatisfiable.

The previous example shows a satisfiable QPTL sentence whose behavioural counterpart becomes unsatisfiable. The opposite may also occur, as the following example illustrates.

$$\begin{array}{l} \chi'_1 = \left\{ \begin{array}{c} 0 \quad 1 \\ q: \quad a \quad b \quad \dots \end{array} \right\} \\ \chi'_2 = \left\{ \begin{array}{c} 0 \quad 1 \\ q: \quad a \quad \bar{b} \quad \dots \end{array} \right\} \end{array} \quad \begin{array}{l} \chi_1 = \left\{ \begin{array}{c} 0 \quad 1 \\ p: \quad c \quad * \quad \dots \\ q: \quad a \quad b \quad \dots \end{array} \right\} \\ \chi_2 = \left\{ \begin{array}{c} 0 \quad 1 \\ p: \quad c \quad * \quad \dots \\ q: \quad a \quad \bar{b} \quad \dots \end{array} \right\} \end{array}$$

Fig. 5. Two schema assignments, with  $a, b, c \in \mathbb{B}$ , where  $\chi'_1, \chi'_2 \in Y$ ,  $\chi_1, \chi_2 \in X \in \text{ext}_B(\{Y\}, p)$ ,  $\bar{b}$  denotes the dual of  $b$ , and  $*$  denotes a don't-care value.

**Example 7.** Consider the QPTL sentence  $\exists q. \forall p. \psi$ , with  $\psi \triangleq p \leftrightarrow \chi q$ , which allows for non-behavioural functors/strategies. According to the classic Tarskian semantics of QPTL, the sentence is unsatisfiable. In game-theoretic terms, indeed, Abelard can falsify  $\psi$  by looking at the value of  $q$  one instant in the future and choosing the opposite value as the present value for  $p$ . By Theorem 1, the sentence is unsatisfiable also under the alternating Hodges semantics. On the other hand, if we require that the two players only use behavioural strategies, things may change. In particular, the two GFG-QPTL sentences  $\forall^B p. \exists^S q. \psi$  and  $\exists^B p. \forall^B q. \psi$  are both satisfiable w.r.t. the hyperassignment  $\{\{\emptyset\}\}$  regardless of the alternation flag, being  $\{\{\emptyset\}\}$  self-dual. For the first one, it is enough to observe that the strongly-behavioural functor  $F_S$  of Example 3 allows to mimic any temporal valuation assigned to the proposition  $p$  one instant in the past, as required by the LTL property  $\psi$ . For the second one, we need to show that  $\text{ext}_B(\{Y\}, p) \models^{\forall \exists} \psi$ , with  $Y = \text{Asg}(\{q\})$ . Now, let  $X \in \text{ext}_B(\{Y\}, p)$  be an arbitrary set of assignments obtained by extending those in  $Y$  as prescribed by the behavioural restriction  $B$  associated with the universal quantifier. Also, consider  $\chi_1, \chi_2 \in X$  as two of those assignments that differ on  $q$  at time 1, but are equal at time 0, i.e.,  $\chi_1(q)(0) = \chi_2(q)(0)$ , but  $\chi_1(q)(1) \neq \chi_2(q)(1)$  (see Figure 5). Due to the required behavioralness w.r.t.  $q$  of the functors used in the extension of  $Y$ , we necessarily have that  $\chi_1(p)(0) = \chi_2(p)(0)$ . As a consequence, either  $\chi_1$  or  $\chi_2$  satisfies  $\psi$ , and thus  $\text{ext}_B(\{Y\}, p) \models^{\forall \exists} \psi$ , as required by Item 1b of the semantics. In other words, Abelard cannot behaviourally falsify the sentence, since he can no longer look at the value of  $q$  in the future. Note that the sentence  $\exists^B p. \forall^B q. \psi$  would not allow for encoding the same game in the classic (asymmetric) Hodges-like semantics, as in this type of semantics it is impossible to restrict both the existential and the universal quantifiers at the same time.

**Example 8.** Information leaks via quantification of unused variables is a well-known phenomenon in IF [79]. The same occurs in GFG-QPTL. Consider a formula  $\phi$  where  $p, q \in \text{free}(\phi)$ , but  $u \notin \text{free}(\phi)$ . Then, both the equivalences  $\forall p. \exists u. \exists^B q. \phi \equiv \forall p. \exists q. \phi$  and  $\forall p. \exists^B q. \phi \equiv \forall p. \exists^B u. \exists^B q. \phi$  do hold. However, the equivalence  $\forall p. \exists q. \phi \equiv \forall p. \exists^B q. \phi$  may fail in general. Indeed, an arbitrary functor  $G_q$  for  $q$  in  $\forall p. \exists q. \phi$  can be simulated in  $\forall p. \exists u. \exists^B q. \phi$  by the functors  $F_u = G_q$ , for  $u$ , and  $F_q(\chi) = \chi(u)$ , for  $q$ . Clearly,  $F_q$ , being the identity on  $u$ , is behavioural. Intuitively, the unused non-behaviourally-quantified proposition  $u$  leaks information about the future of  $p$  to  $q$  even if the latter is behaviourally quantified, as it can see the future of  $p$  through the value of  $u$  at the present time instant.

The following example expands on the connection between GFG-QPTL and GFG-Automata briefly mentioned in the introduction and shows that GFG-QPTL can express the property of being good-for-game for an automaton.

**Example 9.** *It is well known that QPTL is able to express any  $\omega$ -regular language [77]. This can be proved by encoding the existence of an accepting run of an arbitrary nondeterministic Büchi word automaton  $\mathcal{N}$  into a formula  $\varphi \triangleq \exists s_1 \dots \exists s_k. \psi$ , where  $\text{free}(\varphi) = \{p_1, \dots, p_n\}$  is the set of propositions needed to encode the alphabet  $\Sigma$  of the recognised language  $L(\mathcal{N})$ , the  $k$  mutually exclusive fresh atomic propositions  $s_1, \dots, s_k$  encode the set of states  $Q = \{q_1, \dots, q_k\}$  of the automaton, and  $\psi$  is the LTL formula encoding the transition function and the Büchi acceptance condition. Formally,  $\{X\} \models^{\exists\forall} \varphi$  iff  $L_X \subseteq L(\mathcal{N})$ , where  $L_X$  is the set of  $\omega$ -words whose encodings over  $p_1, \dots, p_n$  are the assignments in  $X$ . The behavioural GFG-QPTL formula  $\varphi_B \triangleq \exists^B s_1 \dots \exists^B s_k. \psi$  identifies precisely the sublanguages recognised by  $\mathcal{N}$  when the nondeterminism is resolved in a good-for-game manner [33], i.e.,  $\{X\} \models^{\exists\forall} \varphi$  iff (a)  $L_X \subseteq L(\mathcal{N})$ , (b) there exists a function  $\sigma: \Sigma^* \times Q \rightarrow Q$ , choosing a successor state  $\sigma(w, q)$  of a state  $q \in Q$  based on the prefix  $w \in \Sigma^*$  of the input words read up to that moment, and (c) for every  $\omega$ -word  $w \in L_X$ , there exists an accepting run  $\rho \in Q^\omega$  of  $\mathcal{N}$  such that  $(\rho)_{i+1} = \sigma((w)_{\leq i}, (\rho)_i)$ , for every time instant  $i \in \mathbb{N}$ . Intuitively, the function  $\sigma$  is a uniform strategy to resolve the nondeterminism of the automaton and can be clearly modelled by means of behavioural functors. As a consequence, the GFG-QPTL sentence  $\forall p_1 \dots \forall p_n. (\varphi \leftrightarrow \varphi_B)$  is satisfiable iff  $\mathcal{N}$  is a good-for-game automaton.*

### 3.2 Model-Theoretic Analysis

Let us proceed with an elementary *model-theoretic analysis* of GFG-QPTL, showing that it enjoys several basic properties, like *De Morgan laws*, one would expect from a classical logic.

We start by observing the *monotonicity* of both the dualisation and extension operators *w.r.t.* the preorder  $\sqsubseteq$ , a simple property that is a key tool in all subsequent statements.

**Proposition 4.** *Let  $\mathfrak{X}_1, \mathfrak{X}_2 \in \text{HASg}$  be two hyperassignments with  $\mathfrak{X}_1 \sqsubseteq \mathfrak{X}_2$ . Then, the following properties hold true:*

- (1)  $\overline{\mathfrak{X}_2} \sqsubseteq \overline{\mathfrak{X}_1}$ ;
- (2) for every  $(\mathfrak{X}'_2, \mathfrak{X}''_2) \in \text{par}(\mathfrak{X}_2)$ , there exists  $(\mathfrak{X}'_1, \mathfrak{X}''_1) \in \text{par}(\mathfrak{X}_1)$  such that  $\mathfrak{X}'_1 \sqsubseteq \mathfrak{X}'_2$  and  $\mathfrak{X}''_1 \sqsubseteq \mathfrak{X}''_2$ , and, in addition,  $\mathfrak{X}'_2 = \emptyset$  implies  $\mathfrak{X}'_1 = \emptyset$  and  $\mathfrak{X}''_2 = \emptyset$  implies  $\mathfrak{X}''_1 = \emptyset$ ;
- (3)  $\text{ext}_\Theta(\mathfrak{X}_1, p) \sqsubseteq \text{ext}_\Theta(\mathfrak{X}_2, p)$ , for every  $\Theta \in \Theta$  and  $p \in \text{AP}$ .

The preorder  $\sqsubseteq$  between hyperassignments captures the intuitive notion of satisfaction strength *w.r.t.* GFG-QPTL formulae. Indeed, thanks to Item 1 of Definition 3, it holds that, if  $\mathfrak{X}_1 \sqsubseteq \mathfrak{X}_2$ , the hyperassignment  $\mathfrak{X}_1$  satisfies *w.r.t.* the  $\exists\forall$  (*resp.*,  $\forall\exists$ ) semantics less (*resp.*, more) LTL formulae than the hyperassignment  $\mathfrak{X}_2$ , i.e., if  $\mathfrak{X}_1$  (*resp.*,  $\mathfrak{X}_2$ ) satisfies  $\psi$ , then  $\mathfrak{X}_2$  (*resp.*,  $\mathfrak{X}_1$ ) does as well. This property can easily be lifted to arbitrary GFG-QPTL formulae, by a standard structural induction using the monotonicity of the dualization and extension operators, as proven in Electronic Appendix B.

**Theorem 2** (Hyperassignment Refinement). *Let  $\varphi$  be a GFG-QPTL formula and  $\mathfrak{X}_1, \mathfrak{X}_2 \in \text{HASg}_{\sqsubseteq}$  ( $\text{free}(\varphi)$ ) two hyperassignments with  $\mathfrak{X}_1 \sqsubseteq \mathfrak{X}_2$ . Then,  $\mathfrak{X}_1 \models^{\exists\forall} \varphi$  implies  $\mathfrak{X}_2 \models^{\exists\forall} \varphi$  and  $\mathfrak{X}_2 \models^{\forall\exists} \varphi$  implies  $\mathfrak{X}_1 \models^{\forall\exists} \varphi$ .*

As an immediate consequence, we obtain the following result.

**Corollary 1** (Hyperassignment Equivalence). *Let  $\varphi$  be a GFG-QPTL formula and  $\mathfrak{X}_1, \mathfrak{X}_2 \in \text{HASg}_{\sqsubseteq}$  ( $\text{free}(\varphi)$ ) two hyperassignments with  $\mathfrak{X}_1 \equiv \mathfrak{X}_2$ . Then,  $\mathfrak{X}_1 \models^\alpha \varphi$  iff  $\mathfrak{X}_2 \models^\alpha \varphi$ .*

A fundamental feature of the proposed alternating semantics is the *duality* between swapping the players of a hyperassignment  $\mathfrak{X}$ , i.e., swapping the alternation flag, and swapping the choices of the



players, *i.e.*, dualising  $\mathfrak{X}$ . Indeed, the following result states that dualising both the alternation flag  $\alpha$  and the hyperassignment preserves the truth of any formula. This also implies, as one might expect, that double dualization has no effect either. The latter fact is also a consequence of the previous corollary, since  $\mathfrak{X} \equiv \overline{\overline{\mathfrak{X}}}$ , due to Proposition 1. The proof can be found in Electronic Appendix B.

**Theorem 3** (Double Dualization). *Let  $\varphi$  be a GFG-QPTL formula and  $\mathfrak{X} \in \text{HAsg}_{\subseteq}(\text{free}(\varphi))$  a hyperassignment. Then,  $\overline{\mathfrak{X}} \models^{\alpha} \varphi$  iff  $\overline{\overline{\mathfrak{X}}} \models^{\alpha} \varphi$  iff  $\mathfrak{X} \models^{\alpha} \varphi$ .*

The duality property also grants that formulae satisfiability and equivalence do not depend on the specific interpretation  $\alpha$  of hyperassignments: a positive answer for  $\alpha$  implies the same for  $\overline{\alpha}$ . This *invariance* corresponds to the intuition that Eloise and Abelard both agree on the true and false formulae. Similarly, if  $\varphi$  is considered to be equivalent to, or to imply, some other property  $\phi$  by Eloise, the same equivalence, or implication, holds for Abelard as well, and *vice versa*.

**Corollary 2** (Interpretation Invariance). *Let  $\varphi$  and  $\phi$  be GFG-QPTL formulae. Then,  $\varphi$  is  $\exists\forall$ -satisfiable iff  $\varphi$  is  $\forall\exists$ -satisfiable. Also,  $\varphi \Rightarrow^{\exists\forall} \phi$  iff  $\varphi \Rightarrow^{\forall\exists} \phi$  and  $\varphi \equiv^{\exists\forall} \phi$  iff  $\varphi \equiv^{\forall\exists} \phi$ .*

Thanks to this invariance, the following Boolean laws hold.

**Lemma 4** (Boolean Laws). *Let  $\varphi, \varphi_1, \varphi_2$  be GFG-QPTL formulae:*

- (1)  $\varphi \equiv \neg\neg\varphi$ ;
- (2)  $\varphi_1 \wedge \varphi_2 \Rightarrow \varphi_1$ ;
- (3)  $\varphi_1 \Rightarrow \varphi_1 \vee \varphi_2$ ;
- (4)  $\varphi_1 \wedge \varphi_2 \equiv \varphi_2 \wedge \varphi_1$ ;
- (5)  $\varphi_1 \vee \varphi_2 \equiv \varphi_2 \vee \varphi_1$ ;
- (6)  $\varphi_1 \wedge (\varphi \wedge \varphi_2) \equiv (\varphi_1 \wedge \varphi) \wedge \varphi_2$ ;
- (7)  $\varphi_1 \vee (\varphi \vee \varphi_2) \equiv (\varphi_1 \vee \varphi) \vee \varphi_2$ ;
- (8)  $\varphi_1 \wedge \varphi_2 \equiv \neg(\neg\varphi_1 \vee \neg\varphi_2)$ ;
- (9)  $\varphi_1 \vee \varphi_2 \equiv \neg(\neg\varphi_1 \wedge \neg\varphi_2)$ ;
- (10)  $\exists^{\Theta} p. \varphi \equiv \neg(\forall^{\Theta} p. \neg\varphi)$ ;
- (11)  $\forall^{\Theta} p. \varphi \equiv \neg(\exists^{\Theta} p. \neg\varphi)$ .

At present, it is not clear whether GFG-QPTL in its full generality enjoys, like QPTL, the *pnf* property. The main problem, here, follows from the information-leak phenomenon reported in Example 8. Indeed, in general, the equivalences  $(\exists p. \phi) \wedge \varphi \equiv \exists p. (\phi \wedge \varphi)$  and  $(\forall p. \phi) \vee \varphi \equiv \forall p. (\phi \vee \varphi)$  fail, even when  $p \notin \text{free}(\varphi)$ , as evidenced by the following example.

**Example 10.** *Consider the formulae  $(\exists p. \phi) \wedge \varphi$  and  $\exists p. (\phi \wedge \varphi)$ , where  $\phi \triangleq \top$  and  $\varphi \triangleq \exists^{\exists} r. (r \leftrightarrow \chi q)$  and the hyperassignment  $\{\{\chi_q, \chi_{\overline{q}}\}\}$ , where  $\chi_q \triangleq \{q \mapsto \perp \top^{\omega}\}$  and  $\chi_{\overline{q}} \triangleq \{q \mapsto \perp^{\omega}\}$ . Obviously,  $\{\{\chi_q, \chi_{\overline{q}}\}\} \not\models^{\exists\forall} \varphi$ . Indeed, every behavioral functor  $F \in \text{Fnc}_{\text{B}}(\{q\})$  for  $r$  would reply uniformly at time 0 to both assignments, *i.e.*,  $F(\chi_q)(0) = F(\chi_{\overline{q}})(0)$ . As a consequence, since  $\chi_{qF}(r)(0) = \chi_{\overline{q}F}(r)(0)$ , but  $\chi_{qF}(q)(1) \neq \chi_{\overline{q}F}(q)(1)$ , either  $\chi_{qF} \triangleq \text{ext}(\chi_q, F, r)$  falsifies  $r \leftrightarrow \chi q$  or  $\chi_{\overline{q}F} \triangleq \text{ext}(\chi_{\overline{q}}, F, r)$  does. This immediately implies that  $\{\{\chi_q, \chi_{\overline{q}}\}\} \not\models^{\exists\forall} (\exists p. \phi) \wedge \varphi$ .*

*On the other hand,  $\{\{\chi_q, \chi_{\overline{q}}\}\} \models^{\exists\forall} \exists p. (\phi \wedge \varphi)$ . To see this, let us consider a non-behavioral functor  $F_p \in \text{Fnc}(\{q\})$  such that  $F_p(\chi)(0) = \chi(q)(1)$ . By the semantics of the existential quantifier,  $\{\{\chi_q, \chi_{\overline{q}}\}\} \models^{\exists\forall} \exists p. (\phi \wedge \varphi)$  iff  $\{X_{F_p}, \dots\} \models^{\exists\forall} \phi \wedge \varphi$ , where  $X_{F_p} \triangleq \text{ext}(\{\{\chi_q, \chi_{\overline{q}}\}, F_p, p\})$  and the ellipsis corresponds to set of assignments obtained by means of other functors. It is easily seen that  $X_{F_p} = \{\chi_{qp}, \chi_{\overline{q}p}\}$ , for the two assignments  $\chi_{qp}$  and  $\chi_{\overline{q}p}$  such that  $\chi_{qp}(p)(0) = \chi_{qp}(q)(1) = \top$  and  $\chi_{\overline{q}p}(p)(0) = \chi_{\overline{q}p}(q)(1) = \perp$ . By the semantics of conjunction, every bipartition  $(\mathfrak{X}_1, \mathfrak{X}_2)$  of  $\{X_{F_p}, \dots\}$  must be such that:  $\phi$  must be satisfied by  $\mathfrak{X}_1$  and  $\mathfrak{X}_1 \neq \emptyset$  or  $\varphi$  is satisfied by  $\mathfrak{X}_2$  and  $\mathfrak{X}_2 \neq \emptyset$ . Since*

$\phi = \top$ , this condition is equivalent to requiring that the entire hyperassignment satisfies  $\phi$ , i.e.,  $\{X_{F_p}, \dots\} \models^{\exists^V} \phi$ . Consider now the behavioral functor  $F_r \in F(\{p, q\})$  that copies the value of  $p$  in  $r$  at each time instant, i.e.,  $F_r(\chi) = \chi(p)$ . Again by the semantics of existential quantifications, we have that  $\{X_{F_p}, \dots\} \models^{\exists^V} \phi$  iff  $\{X_{F_r}, \dots\} \models^{\exists^V} r \leftrightarrow \chi q$ , where  $X_{F_r} \triangleq \text{ext}(X_{F_p}, F_r, r) = \{\chi_{qpr}, \chi_{\overline{qpr}}\}$ , with  $\chi_{qpr}(r)(0) = \chi_{qp}(q)(1) = \top$  and  $\chi_{\overline{qpr}}(r)(0) = \chi_{\overline{qp}}(q)(1) = \perp$ . Since both assignments satisfy  $r \leftrightarrow \chi q$ , we obtain that  $\{\{\chi_q, \chi_{\overline{q}}\}\} \models^{\exists^V} \exists p. (\phi \wedge \phi)$ . Hence,  $(\exists p. \phi) \wedge \phi \not\equiv \exists p. (\phi \wedge \phi)$ .

A similar problem arises in IF due to *signalling*, if one allows quantifications depend on non-free variables [55]. For the purposes of this work, however, we shall focus on *pnf* formulae whose quantifier prefixes do not contain duplicated variables, since, as we shall show later on, behavioural GFG-QPTL is powerful enough to express all  $\omega$ -regular languages, very much like QPTL.

We now introduce an operator on quantifier prefixes, called *evolution*, that, given an arbitrary hyperassignment  $\mathfrak{X}$  and one of its two interpretations  $\alpha$ , computes the result  $\text{evl}_\alpha(\mathfrak{X}, \varphi)$  of the application to  $\mathfrak{X}$  of all quantifiers  $Q^\theta p$  occurring in a prefix  $\varphi$  in that specific order. To this aim, we need to introduce the notion of *coherence* of a quantifier symbol  $Q \in \{\exists, \forall\}$  w.r.t. an alternation flag  $\alpha \in \{\exists\forall, \forall\exists\}$  as follows:  $Q$  is  $\alpha$ -coherent if either  $\alpha = \exists\forall$  and  $Q = \exists$  or  $\alpha = \forall\exists$  and  $Q = \forall$ . Essentially, the evolution operator iteratively applies the semantics of quantifiers, as defined by Items 5a' and 6a' of Definition 7 and Items 5b and 6b of Definition 3, for all the quantifiers  $Q^\theta p$  in the input prefix  $\varphi$ . For a single quantifier,  $\text{evl}_\alpha(\mathfrak{X}, Q^\theta p)$  just corresponds to the  $\theta$ -extension of  $\mathfrak{X}$  with  $p$ , when  $Q$  is  $\alpha$ -coherent. On the contrary, when  $Q$  is  $\bar{\alpha}$ -coherent, we need to dualise the  $\theta$ -extension with  $p$  of the dual of  $\mathfrak{X}$ .

$$\text{evl}_\alpha(\mathfrak{X}, Q^\theta p) \triangleq \begin{cases} \text{ext}_\theta(\mathfrak{X}, p), & \text{if } Q \text{ is } \alpha\text{-coherent;} \\ \text{ext}_\theta(\overline{\mathfrak{X}}, p), & \text{otherwise.} \end{cases}$$

The operator lifts naturally to an arbitrary quantification prefix  $\varphi \in \text{Qn}$  as follows: (1)  $\text{evl}_\alpha(\mathfrak{X}, \epsilon) \triangleq \mathfrak{X}$ ; (2)  $\text{evl}_\alpha(\mathfrak{X}, Q^\theta p. \varphi) \triangleq \text{evl}_\alpha(\text{evl}_\alpha(\mathfrak{X}, Q^\theta p), \varphi)$ . We also set  $\text{evl}_\alpha(\varphi) \triangleq \text{evl}_\alpha(\{\{\emptyset\}\}, \varphi)$ .

It is easy to show that the evolution operator is monotone w.r.t.  $\sqsubseteq$ , by simply exploiting the monotonicity of the dualisation and extension operators given in Proposition 4.

**Proposition 5.** *Let  $\mathfrak{X}_1, \mathfrak{X}_2 \in \text{HAsg}$  be two hyperassignments with  $\mathfrak{X}_1 \sqsubseteq \mathfrak{X}_2$  and  $\varphi \in \text{Qn}$ . Then, the following holds true:  $\text{evl}_\alpha(\mathfrak{X}_1, \varphi) \sqsubseteq \text{evl}_\alpha(\mathfrak{X}_2, \varphi)$ .*

By simple structural induction on a quantifier prefix  $\varphi \in \text{Qn}$ , we can show that a hyperassignment  $\mathfrak{X}$   $\alpha$ -satisfies a formula  $\varphi\phi$  iff its  $\alpha$ -evolution w.r.t.  $\varphi$   $\alpha$ -satisfies  $\phi$ .

**Lemma 5 (Prefix Evolution).** *Let  $\varphi\phi$  be a GFG-QPTL formula with quantifier prefix  $\varphi \in \text{Qn}$ . Then,  $\mathfrak{X} \models^\alpha \varphi\phi$  iff  $\text{evl}_\alpha(\mathfrak{X}, \varphi) \models^\alpha \phi$ , for all hyperassignments  $\mathfrak{X} \in \text{HAsg}(\text{free}(\varphi\phi))$ .*

## 4 QUANTIFICATION GAMES

The satisfiability problem for the behavioural fragment of GFG-QPTL can be solved by showing the existence of a game, played by Eloise and Abelard, with the property that Eloise wins the game iff the corresponding formula is indeed satisfiable. We provide here a general result, showing that, for any behavioural quantifier prefix  $\varphi$  and Borelian property  $\Psi$ <sup>1</sup>, there exists a game, called *quantification game*, such that Eloise wins the game iff the hyperassignment obtained by evaluating

<sup>1</sup>By Borelian property we mean an arbitrary set of assignments (possibly, but non-necessarily, induced by an LTL formula  $\psi$ ) corresponding to a set in the Borel hierarchy built upon a suitable Cantor topological space [68]; we recall that, starting from the open sets in the space (e.g., eventuality properties, such as, those induced by LTL formulae of the form  $F p$ ), the hierarchy is uniquely built by applying the operations of countable union, countable intersection, and complementation.

the prefix, namely  $\text{evl}_{\exists\forall}(\wp)$ , contains a set of assignments completely included in  $\Psi$ . The correctness of this result depends, in turn, on the existence of canonical forms for the quantifier prefixes that allow one to reduce the alternations to at most one.

#### 4.1 Quantification Game for Sentences

To define the quantification game, we first need a few preliminary notions.

Given a set  $S$ , we use as usual  $S^*$  (resp.,  $S^\omega$ ) to denote the set of finite (resp. infinite) sequences over the alphabet  $S$ , and  $S^\infty = S^* \cup S^\omega$ . For  $\pi \in S^*$  and  $i \in \mathbb{N}$ , we use  $(\pi)_i$ ,  $(\pi)_{\leq i}$ ,  $\text{fst}(\pi)$ , and  $\text{lst}(\pi)$ , to denote, respectively, the  $i$ -th element of  $\pi$ , the prefix of  $\pi$  up to index  $i$  included, the first (0-th) element of  $\pi$ , and, finally, the last element of  $\pi$ .

A two-player turn-based *arena*  $\mathcal{A} = \langle \text{Ps}_E, \text{Ps}_A, v_I, Mv \rangle$  is a tuple where (1)  $\text{Ps}_E$  and  $\text{Ps}_A$  are the disjoint sets (i.e.  $\text{Ps}_E \cap \text{Ps}_A = \emptyset$ ) of *positions* of *Eloise* and *Abelard*, a.k.a. *Player* and *Opponent*, respectively, with  $\text{Ps} \triangleq \text{Ps}_E \cup \text{Ps}_A$  denoting the set of all positions, (2)  $v_I \in \text{Ps}$  is the *initial position*, and (3)  $Mv \subseteq \text{Ps} \times \text{Ps}$  is the binary relation describing all possible *moves* such that  $\langle \text{Ps}, Mv \rangle$  is a sinkless directed graph. A *path*  $\pi \in \text{Pth} \subseteq \text{Ps}^\infty$  is a finite or infinite sequence of positions compatible with the move relation, i.e.,  $((\pi)_i, (\pi)_{i+1}) \in Mv$ , for all  $i \in [0, |\pi| - 1]$ ; it is *initial* if  $|\pi| > 0$  and  $\text{fst}(\pi) = v_I$ . A *history* for player  $\alpha \in \{E, A\}$  is a finite initial path  $\rho \in \text{Hst}_\alpha \subseteq \text{Pth} \cap (\text{Ps}^* \cdot \text{Ps}_\alpha)$  terminating in an  $\alpha$ -position. A *play*  $\pi \in \text{Play} \subseteq \text{Pth} \cap \text{Ps}^\omega$  is just an infinite initial path. A *strategy* for player  $\alpha \in \{E, A\}$  is a function  $\sigma_\alpha \in \text{Str}_\alpha \subseteq \text{Hst}_\alpha \rightarrow \text{Ps}$  mapping each  $\alpha$ -history  $\rho \in \text{Hst}_\alpha$  to a position  $\sigma_\alpha(\rho) \in \text{Ps}$  compatible with the move relation, i.e.,  $(\text{lst}(\rho), \sigma_\alpha(\rho)) \in Mv$ . A path  $\pi \in \text{Pth}$  is *compatible with a pair of strategies*  $(\sigma_E, \sigma_A) \in \text{Str}_E \times \text{Str}_A$  if, for all  $i \in [0, |\pi| - 1]$ , it holds that  $(\pi)_{i+1} = \sigma_E((\pi)_{\leq i})$ , if  $(\pi)_i \in \text{Ps}_E$ , and  $(\pi)_{i+1} = \sigma_A((\pi)_{\leq i})$ , otherwise. As one may expect, we say that a path is *compatible with a strategy*  $\sigma_E \in \text{Str}_E$  if it is compatible with the pair of strategies  $(\sigma_E, \sigma_A) \in \text{Str}_E \times \text{Str}_A$ , for some strategy  $\sigma_A \in \text{Str}_A$ . The *play function*  $\text{play}: \text{Str}_E \times \text{Str}_A \rightarrow \text{Play}$  returns, for each pair of strategies  $(\sigma_E, \sigma_A) \in \text{Str}_E \times \text{Str}_A$ , the unique play  $\text{play}(\sigma_E, \sigma_A) \in \text{Play}$  compatible with them.

A *game*  $\mathcal{G} = \langle \mathcal{A}, \text{Ob}, \text{Wn} \rangle$  is a tuple where  $\mathcal{A}$  is an arena,  $\text{Ob} \subseteq \text{Ps}$  is the set of *observable positions*, and  $\text{Wn} \subseteq \text{Ob}^\omega$  is the set of *observable sequences* that are *winning* for Eloise; the complement  $\overline{\text{Wn}} \triangleq \text{Ob}^\omega \setminus \text{Wn}$  is *winning* for Abelard. The *observation function*  $\text{obs}: \text{Pth} \rightarrow \text{Ob}^\omega$  associates with each path  $\pi \in \text{Pth}$  the ordered sequence  $w \triangleq \text{obs}(\pi) \in \text{Ob}^\omega$  of all observable positions occurring in it. In other words,  $w$  is the maximal subsequence of  $\pi$  that contains only positions in  $\text{Ob}$ . Formally, there exists a monotone bijection  $f: [0, |w|] \rightarrow \{j \in [0, |\pi|] \mid (\pi)_j \in \text{Ob}\}$  satisfying the equality  $(w)_i = (\pi)_{f(i)}$ , for all  $i \in [0, |w|]$ . Eloise (resp., Abelard) *wins* the game if she (resp., he) has a strategy  $\sigma_E \in \text{Str}_E$  (resp.  $\sigma_A \in \text{Str}_A$ ) such that, for all adversary strategies  $\sigma_A \in \text{Str}_A$  (resp.,  $\sigma_E \in \text{Str}_E$ ), the corresponding play  $\text{play}(\sigma_E, \sigma_A)$  induces an observation sequence  $\text{obs}(\text{play}(\sigma_E, \sigma_A))$  belonging (resp., not belonging) to  $\text{Wn}$ . Notice that, even if the winning conditions are defined on a subset of observable positions, here we only consider perfect-information games, since strategies have, instead, full knowledge of the entire set of histories.

Martin's determinacy theorem [56, 57] states that all games whose winning condition is a Borel set in the Cantor topological space of infinite words [68] are determined, i.e., one of the two players necessarily wins the game. To ensure that the quantification game we are about to define is indeed determined, we require a form of Borelian condition that can be applied to sets of assignments. This determinacy requirement is crucial here, since it is tightly connected with the fact that GFG-QPTL does not allow for undetermined formulae. To this end, let  $\text{Val} \triangleq \text{AP} \rightarrow \mathbb{B}$  denote the set of Boolean valuations for sets of propositions and  $\text{Val}(P) \triangleq \{\xi \in \text{Val} \mid \text{dom}(\xi) = P\}$  the set of valuations for propositions in  $P \subseteq \text{AP}$ . Also,  $\#(\xi) \triangleq |\text{dom}(\xi)|$ . We can now define a bijection between sets of assignments over  $P$  and languages of infinite words over the alphabet  $\text{Val}(P)$ . Let

$\text{wrđ} : \text{Asg}(\mathbb{P}) \rightarrow \text{Val}(\mathbb{P})^\omega$  be the *word function* mapping each assignment  $\chi \in \text{Asg}(\mathbb{P})$  to the word  $w \triangleq \text{wrđ}(\chi) \in \text{Val}(\mathbb{P})^\omega$  satisfying the equality  $\chi(p)(t) = (w)_t(p)$ , for all  $p \in \mathbb{P}$  and  $t \in \mathbb{N}$ . Clearly  $\text{wrđ}$  is a bijection. Now, every property  $\Psi \subseteq \text{Asg}(\mathbb{P})$ , i.e., every set of assignments, uniquely induces the language of infinite words  $\text{wrđ}(\Psi) \triangleq \{\text{wrđ}(\chi) \mid \chi \in \Psi\} \subseteq \text{Val}(\mathbb{P})^\omega$  over the alphabet  $\text{Val}(\mathbb{P})$ . Thus,  $\Psi$  is said to be *Borelian* (resp., regular) if the language  $\text{wrđ}(\Psi)$  is a Borel (resp., regular) set.

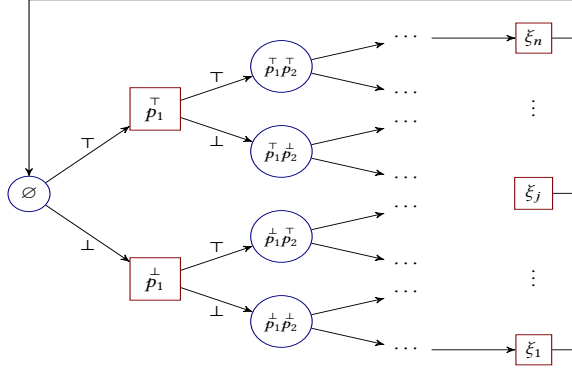

Fig. 6. Quantification game for the sentence  $\varphi = \exists^{\text{B}} p_1. \forall^{\text{B}} p_2. \exists^{\text{B}} p_3 \dots$ . Eloise owns the circled positions, while Abelard the squared ones. From the total-valuation positions  $\xi_1, \dots, \xi_n$ , with  $n = 2^{|\text{ap}(\varphi)|}$ , Abelard moves to the initial position with empty evaluation.

Given a behavioural sentence  $\varphi\psi$ , let  $L(\psi) \subseteq \text{Asg}(\text{ap}(\varphi))$  denote the set of assignments satisfying the LTL formula  $\psi$ . The quantification game  $\mathcal{D}_{\varphi}^{\psi} \triangleq \mathcal{D}_{\varphi}^{L(\psi)}$  is defined in Construction 1 and exemplified in Figure 6. Recall that we assume that the prefix  $\varphi$  does not contain duplicates, namely every variable is quantified over at most once in the prefix. The positions of the game are (partial) valuations of the propositions in  $\varphi$  and each position belongs to the player corresponding to the first quantifier in the prefix whose proposition is not defined at that position. The initial position of the game contains the empty valuation and in the example of Figure 6 belongs to Eloise, since she is the first to play in  $\varphi$ . Obviously, the game features an infinite number of rounds. Each round begins with the empty valuation and ends in a total valuation, after the players have chosen (jointly) a value for all the propositions. A move in the round corresponds to a player choosing a value for the next proposition in the prefix  $\varphi$ . Take, for instance, position  $\xi \triangleq \{p_1 \mapsto \perp\}$  in the figure, where the first proposition  $p_1$  has been already assigned value  $\perp$  by Eloise. From that position, Abelard first chooses a Boolean value, say  $\top$ , for the next proposition  $p_2$  in the prefix. Then he moves to the position  $\xi' \triangleq \{p_1 \mapsto \perp, p_2 \mapsto \top\}$ , corresponding to the valuation  $\xi[p_2 \mapsto \top]$ , obtained by extending  $\xi$  with the value chosen for  $p_2$ . Position  $\xi'$  belongs to Eloise, since the next quantifier  $\exists p_3$  in the prefix is existential. The last positions belong to Abelard and, from there, he can only move back to the starting position for the next turn. By sampling any infinite sequence of rounds of the games at the positions with total valuations, namely the observable positions, we obtain an infinite word  $w$  corresponding to some assignment  $\chi \triangleq \text{wrđ}^{-1}(w)$ . Then,  $w$  is winning for Eloise iff  $\chi$  belongs to  $\Psi \triangleq L(\psi)$  (i.e.,  $\chi \models \psi$ ), while it is winning for Abelard otherwise. This intuition is formalised by the following construction.

**Construction 1** (Quantification Game I). *For every behavioral quantifier prefix  $\varphi \in \text{Qn}_{\text{B}}$  and property  $\Psi \subseteq \text{Asg}(\text{ap}(\varphi))$ , the game  $\mathcal{D}_{\varphi}^{\Psi} \triangleq \langle \mathcal{A}_{\varphi}, \text{Ob}, \text{Wn} \rangle$  with arena  $\mathcal{A}_{\varphi} \triangleq \langle \text{Ps}_{\text{E}}, \text{Ps}_{\text{A}}, v_I, Mv \rangle$  is defined as prescribed in the following:*

- the set of positions  $\text{Ps} \subseteq \text{Val}$  contains exactly those valuations  $\xi \in \text{Val}$  of the propositions in  $\text{ap}(\wp)$  that are quantified in the prefix  $(\wp)_{<\#(\xi)}$  of  $\wp$  having length  $\#(\xi)$  i.e.,  $\text{dom}(\xi) = \text{ap}((\wp)_{<\#(\xi)})$ ;
- the set of Eloise's positions  $\text{Ps}_E \subseteq \text{Ps}$  only contains the valuations  $\xi \in \text{Ps}$  for which the proposition quantified in  $\wp$  at index  $\#(\xi)$  is existentially quantified, i.e.,  $(\wp)_{\#(\xi)} = \exists^B p$ , for some  $p \in \text{ap}(\wp)$ ;
- the initial position  $v_1 \triangleq \emptyset$  is just the empty valuation;
- the move relation  $Mv \subseteq \text{Ps} \times \text{Ps}$  contains exactly those pairs of valuations  $(\xi_1, \xi_2) \in \text{Ps} \times \text{Ps}$  such that:
  - $\xi_1 \subseteq \xi_2^2$  and  $\#(\xi_2) = \#(\xi_1) + 1$ , or
  - $\xi_1 \in \text{Val}(\text{ap}(\wp))$  and  $\xi_2 = \emptyset$ ;
- the set of observable positions  $\text{Ob} \triangleq \text{Val}(\text{ap}(\wp))$  precisely contains the valuations of all the propositions in  $\wp$ ;
- the winning condition induced by the property  $\Psi$  is the language of infinite words  $\text{Wn} \triangleq \text{wr}d(\Psi)$  over  $\text{Val}(\text{ap}(\wp))$ .

The game  $\mathcal{D}_\wp^\psi$  above essentially provides a game-theoretic version of the semantics of behavioural quantifications. The correctness of the game is established by the following theorem.

**Theorem 4** (Game-Theoretic Semantics I). *A behavioural GFG-QPTL sentence  $\wp\psi$ , with  $\psi \in \text{LTL}$ , is satisfiable (resp., unsatisfiable) iff Eloise (resp., Abelard) wins  $\mathcal{D}_\wp^\psi$ .*

The proof of this result is split into the following three steps. First, for an arbitrary behavioural quantifier prefix  $\wp$ , we provide two syntactic transformations,  $C_{\exists\forall}(\wp)$  and  $C_{\forall\exists}(\wp)$ , called *canonicalisations*, which allow one to reduce a behavioural GFG-QPTL sentence  $\varphi = \wp\psi$  to the sentences  $C_{\exists\forall}(\wp)\psi$  and  $C_{\forall\exists}(\wp)\psi$  featuring at most a single alternation of quantifiers. Second, in Theorem 5, we connect the winner of the game  $\mathcal{D}_\wp^\psi$  with the satisfiability of one of the normal forms  $C_{\exists\forall}(\wp)\psi$  and  $C_{\forall\exists}(\wp)\psi$ , showing also that  $C_{\exists\forall}(\wp)\psi$  implies  $C_{\forall\exists}(\wp)\psi$ . Finally, in Theorem 6, we prove that the original sentence  $\varphi$  is equisatisfiable with the two normal forms.

Let us start with the definition of the two prefix canonicalisations based on the following syntactic quantifier-swap operations. Consider, e.g., the formula  $\forall^B p. \exists^B q. \phi$ . A *naïve* quantifier-swap operator would simply swap the two quantifiers that, in game-theoretic terms, corresponds to swapping the choices of the two players, which allows Abelard to see Eloise's move at the current round. To balance this additional power, we restrict the universal quantifier to be strictly behavioural, thus preventing Abelard from reading Eloise's choice. This leads to the formula  $\exists^B q. \forall^{\langle B:AP \rangle_{S:q}} p. \psi$ . A symmetric swap operation would transform the formula  $\exists^B q. \forall^B p. \phi$  into  $\forall^B p. \exists^{\langle B:AP \rangle_{S:p}} q. \phi$ . Essentially, the swap operation exchanges the positions of two adjacent dual behavioural quantifiers and restricts the inner one to be strongly behavioural *w.r.t.* the proposition of the outer one. By iteratively swapping adjacent quantifiers and adjusting the quantifier specification accordingly, we can reduce the quantifier alternation to at most one, still preserving the dependencies in the quantifications at each instant of time.

For technical convenience we use a vector notation for the quantifier prefixes:

$$Q^{\vec{\theta}} \vec{p}. \phi \triangleq Q^{(\vec{\theta})_0}(\vec{p})_0 \dots Q^{(\vec{\theta})_k}(\vec{p})_k. \phi,$$

where  $|\vec{p}| = |\vec{\theta}| = k + 1$ . We omit the vector symbol in  $\vec{\theta}$  if this is just a sequence of B or S specifications and consider  $\vec{p}$  as sets of propositions when convenient. We also define in a natural way the union of two quantifier specifications as follows:

$$\left\langle \begin{array}{l} B : P_{B1} \\ S : P_{S1} \end{array} \right\rangle \cup \left\langle \begin{array}{l} B : P_{B2} \\ S : P_{S2} \end{array} \right\rangle \triangleq \left\langle \begin{array}{l} B: P_{B1} \cup P_{B2} \\ S: P_{S1} \cup P_{S2} \end{array} \right\rangle.$$

<sup>2</sup>As usual,  $\xi_1 \subseteq \xi_2$  denotes the inclusion between functions, i.e.,  $\text{dom}(\xi_1) \subseteq \text{dom}(\xi_2)$  and  $\xi_1(x) = \xi_2(x)$ , for all  $x \in \text{dom}(\xi_1)$ .

Given a behavioural quantifier prefix  $\wp \in \mathbf{Qn}_B$ , the two syntactic transformations  $C_{\exists\forall}(\cdot)$  and  $C_{\forall\exists}(\cdot)$  yield the single-alternation prefixes  $C_{\exists\forall}(\wp)$  and  $C_{\forall\exists}(\wp)$ , by applying all the quantifier swap operations at once. More specifically, the function  $C_{\exists\forall}(\cdot)$  provides an  $\exists\forall$ -prefix, where all existential quantifiers precede the universal ones, while  $C_{\forall\exists}(\cdot)$  gives us the the dual  $\forall\exists$ -prefix.

For the definition of  $C_{\exists\forall}(\cdot)$ , we observe that every behavioural quantifier prefix  $\wp$  can be written in the following form:

$$\wp = \exists^B \vec{q}_0. (\forall^B \vec{p}_i. \exists^B \vec{q}_i)_{i=1}^k. \forall^B \vec{p}_{k+1},$$

for some  $k \in \mathbb{N}$  and vectors  $\vec{q}_i$ , with  $i \in [0, k]$ , and  $\vec{p}_i$ , with  $i \in [1, k + 1]$ , where  $|\vec{q}_i|, |\vec{p}_i| \geq 1$ , for all  $i \in [1, k]$ . For a quantifier prefix  $\wp$  we then define

$$C_{\exists\forall}(\wp) \triangleq (\exists^B \vec{q}_i)_{i=0}^k. (\forall^{\vec{\Theta}_i} \vec{p}_i)_{i=1}^{k+1},$$

where  $\vec{\Theta}_i$  is a vector, for every  $i \in [1, k + 1]$ , whose components are defined as  $(\vec{\Theta}_i)_j \triangleq B \cup \langle S : \vec{q}_i \cdots \vec{q}_k \rangle$ , for all  $j \in [0, |\vec{p}_i|]$ .

The definition of  $C_{\forall\exists}(\cdot)$  is analogous. First, we write a prefix  $\wp$  in the form:

$$\wp = \forall^B \vec{p}_0. (\exists^B \vec{q}_i. \forall^B \vec{p}_i)_{i=1}^k. \exists^B \vec{q}_{k+1},$$

for some  $k \in \mathbb{N}$  and vectors  $\vec{p}_i$ , with  $i \in [0, k]$ , and  $\vec{q}_i$ , with  $i \in [1, k + 1]$ , where  $|\vec{p}_i|, |\vec{q}_i| \geq 1$ , for all  $i \in [1, k]$ . Then, we define

$$C_{\forall\exists}(\wp) \triangleq (\forall^B \vec{p}_i)_{i=0}^k. (\exists^{\vec{\Theta}_i} \vec{q}_i)_{i=1}^{k+1},$$

where  $\vec{\Theta}_i$  is a vector, for every  $i \in [1, k + 1]$ , whose components are defined as  $(\vec{\Theta}_i)_j \triangleq B \cup \langle S : \vec{p}_i \cdots \vec{p}_k \rangle$ , for all  $j \in [0, |\vec{q}_i|]$ .

**Example 11.** Consider the behavioural quantifier prefix  $\wp = \forall^B p. \exists^B q r. \forall^B s. \exists^B t$ . The corresponding  $\exists\forall$  canonical-form is  $C_{\exists\forall}(\wp) = \exists^B q r t. \forall^{\Theta^p} p. \forall^{\Theta^s} s$ , where  $\Theta^p \triangleq \langle \begin{smallmatrix} B:AP \\ S:qr t \end{smallmatrix} \rangle$  and  $\Theta^s \triangleq \langle \begin{smallmatrix} B:AP \\ S:t \end{smallmatrix} \rangle$ . The  $\forall\exists$  canonical-form prefix is, instead,  $C_{\forall\exists}(\wp) = \forall^B p s. \exists^{\Theta} q r. \exists^B t$ , where  $\Theta \triangleq \langle \begin{smallmatrix} B:AP \\ S:s \end{smallmatrix} \rangle$ .

For the second part of the proof of Theorem 4, we need to connect the winner of  $\mathcal{D}_\wp^\psi$  with the satisfiability of (one among)  $C_{\exists\forall}(\wp)\psi$  and  $C_{\forall\exists}(\wp)\psi$ . This also corresponds to showing that  $C_{\exists\forall}(\wp)\psi \Rightarrow C_{\forall\exists}(\wp)\psi$ . To this end, we exploit the  $\omega$ -regularity of LTL languages, which ensures that the game is Borelian.

**Theorem 5** (Quantification Game I). *For each behavioural quantification prefix  $\wp \in \mathbf{Qn}_B$  and Borelian property  $\Psi \subseteq \text{Asg}(\text{ap}(\wp))$ , the game  $\mathcal{D}_\wp^\Psi$  satisfies the following two properties:*

- 1) if Eloise wins then  $E \subseteq \Psi$ , for some  $E \in \text{evl}_{\exists\forall}(C_{\exists\forall}(\wp))$ ;
- 2) if Abelard wins then  $E \not\subseteq \Psi$ , for all  $E \in \text{evl}_{\exists\forall}(C_{\exists\forall}(\wp))$ .

The idea of the proof is to extract from a winning strategy of Eloise (*resp.*, Abelard) a vector  $\vec{F}$  of functors, one for each proposition associated with that player, witnessing the existence (*resp.*, non-existence) of a set  $E$  of assignments that satisfies the property  $\Psi$ . More precisely, assume Eloise has a strategy  $\sigma$  to win the game and let  $\forall^B \vec{p}. \exists^B \vec{q} = C_{\forall\exists}(\wp)$  be the  $\forall\exists$  canonical-form of  $\wp$ . Then, thanks to the bijection between plays  $\pi$  and assignments  $\chi$ , we can operate as follows, for every round  $k$  and existential proposition  $q_i$  in  $\vec{q}$ : given Abelard's choices up to round  $k$  in  $\pi$ , we can extract, from Eloise's response for  $q_i$  in  $\sigma$ , the response to  $\chi$  at time  $k$  of the functor  $F_i$  in  $\vec{F}$ . As a consequence, for all  $\chi \in \text{Asg}(\vec{p})$  chosen by Abelard, Eloise's response corresponding to the extension of  $\chi$  with  $\vec{F}$  on  $\vec{q}$  satisfies, *i.e.*, belongs to, the property  $\Psi$ . The witness  $E$  is precisely the set of all those extensions. An analogous argument applies to Abelard for the  $\exists\forall$  canonical-form. Notice that  $\vec{F}$  meets the specification  $\vec{\Theta}$  thanks to the alternation of the players prescribed by  $\wp$  in

each round of  $\mathcal{D}_{\wp}^{\Psi}$ . A detailed proof is provided in Electronic Appendix C. The following result is now immediate.

**Corollary 3** (Quantification Game I). *For every behavioural GFG-QPTL sentence  $\wp\psi$ , with  $\psi \in \text{LTL}$ , the game  $\mathcal{D}_{\wp}^{\Psi}$  satisfies the following two properties:*

- 1) if Eloise (resp., Abelard) wins then  $C_{\forall\exists}(\wp)\psi$  is satisfiable (resp.,  $C_{\exists\forall}(\wp)\psi$  is unsatisfiable);
- 2) if  $C_{\exists\forall}(\wp)\psi$  is satisfiable (resp.,  $C_{\forall\exists}(\wp)\psi$  is unsatisfiable) then Eloise (resp., Abelard) wins.

**PROOF.** Item 1 immediately follows from Item 1 of Definition 3, Lemma 5 and the two items of Theorem 5. For Item 2, instead, let us assume that  $C_{\exists\forall}(\wp)\psi$  is satisfiable (resp.,  $C_{\forall\exists}(\wp)\psi$  is unsatisfiable). Thanks to Item 1 of Definition 3 and Lemma 5, if  $\{\{\emptyset\}\} \models^{\exists\forall} C_{\exists\forall}(\wp)\psi$  (resp.,  $\{\{\emptyset\}\} \not\models^{\exists\forall} C_{\forall\exists}(\wp)\psi$ ), then  $E \subseteq \Psi \triangleq L(\psi)$ , for some  $E \in \text{evl}_{\exists\forall}(C_{\exists\forall}(\wp)) = \text{evl}_{\exists\forall}(\{\{\emptyset\}\}, C_{\exists\forall}(\wp))$  (resp.,  $E \not\subseteq \Psi$ , for all  $E \in \text{evl}_{\exists\forall}(C_{\forall\exists}(\wp)) = \text{evl}_{\exists\forall}(\{\{\emptyset\}\}, C_{\forall\exists}(\wp))$ ). Thus, by Item 2 (resp., Item 1) of Theorem 5, it follows that Abelard (resp., Eloise) loses the game  $\mathcal{D}_{\wp}^{\Psi}$  which means, by determinacy, that Eloise (resp., Abelard) wins. Recall that  $\mathcal{D}_{\wp}^{\Psi}$  is determined, since its winning condition is Borelian [56].  $\square$

The final step establishes the equisatisfiability of a behavioural GFG-QPTL sentence  $\wp\psi$  with its two canonical forms  $C_{\exists\forall}(\wp)\psi$  and  $C_{\forall\exists}(\wp)\psi$ .

**Theorem 6** (Sentence Canonical Forms). *For every behavioural GFG-QPTL sentence  $\wp\psi$ , with  $\psi \in \text{LTL}$ , it holds that  $\wp\psi$ ,  $C_{\exists\forall}(\wp)\psi$ , and  $C_{\forall\exists}(\wp)\psi$  are equisatisfiable.*

Towards the proof, we can derive the chain of implications  $C_{\forall\exists}(\wp)\psi \Rightarrow \wp\psi \Rightarrow C_{\exists\forall}(\wp)\psi$  by exploiting the following property of the evolution function. Specifically, this asserts a total ordering w.r.t. the preorder  $\sqsubseteq$  between a behavioural quantifier prefix  $\wp$  and its two canonical forms  $C_{\exists\forall}(\wp)$  and  $C_{\forall\exists}(\wp)$ , which can be proved by induction on the structure of  $\wp$ .

**Proposition 6.**  $\text{evl}_{\alpha}(\mathfrak{X}, C_{\bar{\alpha}}(\wp)) \sqsubseteq \text{evl}_{\alpha}(\mathfrak{X}, \wp) \sqsubseteq \text{evl}_{\alpha}(\mathfrak{X}, C_{\alpha}(\wp))$ , for all hyperassignments  $\mathfrak{X} \in \text{HAsg}$  and behavioral quantifier prefixes  $\wp \in \text{Qn}_{\text{B}}$ , with  $\text{ap}(\wp) \cap \text{ap}(\mathfrak{X}) = \emptyset$ .

**PROOF OF THEOREM 6.** From Proposition 6, Lemma 5, and Theorem 2, the chain of implications  $C_{\forall\exists}(\wp)\psi \Rightarrow \wp\psi \Rightarrow C_{\exists\forall}(\wp)\psi$  easily follows. Indeed, by Lemma 5, we have that (1)  $\wp\psi$  is satisfiable iff  $\text{evl}_{\exists\forall}(\wp) \models^{\exists\forall} \psi$ , (2)  $C_{\exists\forall}(\wp)\psi$  is satisfiable iff  $\text{evl}_{\exists\forall}(C_{\exists\forall}(\wp)) \models^{\exists\forall} \psi$ , and (3)  $C_{\forall\exists}(\wp)\psi$  is satisfiable iff  $\text{evl}_{\exists\forall}(C_{\forall\exists}(\wp)) \models^{\exists\forall} \psi$ . Now, by Proposition 6, it holds that  $\text{evl}_{\exists\forall}(C_{\forall\exists}(\wp)) \sqsubseteq \text{evl}_{\exists\forall}(\wp) \sqsubseteq \text{evl}_{\exists\forall}(C_{\exists\forall}(\wp))$ . Therefore, by Theorem 2, we have that if  $C_{\forall\exists}(\wp)\psi$  is satisfiable then  $\wp\psi$  is satisfiable too, which, in turn, implies that  $C_{\exists\forall}(\wp)\psi$  is satisfiable as well. To complete the proof, we need to show that, if  $C_{\exists\forall}(\wp)\psi$  is satisfiable, then also  $C_{\forall\exists}(\wp)\psi$  is satisfiable. This fact is, however, a direct consequence of Corollary 3.  $\square$

We can finally prove of the main result of this subsection, namely Theorem 4.

**PROOF OF THEOREM 4.** We want to prove that  $\wp\psi$  is satisfiable (resp., unsatisfiable) iff Eloise (resp., Abelard) wins  $\mathcal{D}_{\wp}^{\Psi}$ . For the *if-direction*, by Item 1 of Corollary 3, if Eloise (resp., Abelard) wins the game then  $C_{\forall\exists}(\wp)\psi$  is satisfiable (resp.,  $C_{\exists\forall}(\wp)\psi$  is unsatisfiable). However, this implies that  $\wp\psi$  is satisfiable (resp., unsatisfiable), thanks to Theorem 6. For the *only-if-direction*, if  $\wp\psi$  is satisfiable (resp., unsatisfiable) then  $C_{\exists\forall}(\wp)\psi$  is satisfiable (resp.,  $C_{\forall\exists}(\wp)\psi$  is unsatisfiable), again due to Theorem 6. However, this implies, in turn, that Eloise (resp., Abelard) wins the game, thanks to Item 2 of Corollary 3.  $\square$

## 4.2 Quantification Game for Formulae

The game defined in the previous section can easily be adapted to deal with the satisfiability problem for behavioural GFG-QPTL as shown in the next section. Solving the model-checking problem requires, however, a generalisation of Theorem 4, connecting a suitable game with the satisfaction of an arbitrary behavioural formula *w.r.t.* a hyperassignment  $\mathfrak{X}$ . We can prove such a property under the assumption that  $\mathfrak{X}$  is *well-behaved*, *i.e.*,  $\mathfrak{X}$  is the evolution of a Borelian set of assignments  $X$  *w.r.t.* some behavioural prefix  $\tilde{\varphi}$ . The Borelian requirement is again connected to determinacy of the underlying game. The behavioural requirement, instead, allows for a simple proof that leverages the quantification game for sentences directly. At this stage, it is not clear whether the property actually holds for arbitrary Borelian hyperassignments. In the model-checking procedure provided later on, however, both properties are satisfied.

To formalise the two assumptions above, we introduce the notion of *generator* for a hyperassignment  $\mathfrak{X} \in \text{HAsg}$  as a pair  $\langle \tilde{\varphi}, X \rangle$  consisting of (1) a behavioural quantification prefix  $\tilde{\varphi} \in \text{Qn}_B$  and (2) a Borelian set of assignments  $\emptyset \neq X \subseteq \text{Asg}(\text{ap}(\mathfrak{X}) \setminus \text{ap}(\tilde{\varphi}))$  such that  $\mathfrak{X} = \text{evl}_{\exists V}(\{X\}, \tilde{\varphi})$ . A hyperassignment  $\mathfrak{X} \in \text{HAsg}$  is *Borelian behavioural* if there is a generator for it.

The new quantification game is defined *w.r.t.* a *quantification-game schema* that comprises the input hyperassignment  $\mathfrak{X}$ , the quantification prefix  $\varphi$  describing how the players alternate in the game, and the Borelian property  $\Psi$  corresponding to the desired goal.

**DEFINITION 8 (QUANTIFICATION-GAME SCHEMA).** *A quantification-game schema is a tuple  $\Omega \triangleq \langle \mathfrak{X}, \varphi, \Psi \rangle$ , where (1)  $\mathfrak{X} \in \text{HAsg}$  is Borelian behavioural, (2)  $\varphi \in \text{Qn}_B$  is a behavioural quantification prefix, (3)  $\Psi \subseteq \text{Asg}(\text{ap}(\varphi) \cup \text{ap}(\mathfrak{X}))$  is Borelian, and (4)  $\text{ap}(\varphi) \cap \text{ap}(\mathfrak{X}) = \emptyset$ .*

The idea behind the game-theoretic construction reported below is quite simple. Given a generator  $\langle \tilde{\varphi}, X \rangle$  for a behavioural hyperassignment  $\mathfrak{X}$ , we force the two players to simulate the given  $\mathfrak{X}$  by playing according to the prefix  $\tilde{\varphi}$ , once Abelard has arbitrarily chosen the values of the atomic propositions  $\vec{p}$  over which the set of assignments  $X$  is defined. Since  $\text{evl}_{\exists V}(\forall \vec{p}) = \{\text{Asg}(\vec{p})\}$  and  $X \subseteq \text{Asg}(\vec{p})$ , it is clear that  $\text{evl}_{\exists V}(\forall \vec{p}) \sqsubseteq \{X\}$  and, by the monotonicity property stated in Proposition 5, we have that  $\text{evl}_{\exists V}(\forall \vec{p}, \tilde{\varphi}) \sqsubseteq \mathfrak{X} = \text{evl}_{\exists V}(\{X\}, \tilde{\varphi})$ . Thus, if Eloise wins the game, she can ensure a given temporal property, *i.e.*,  $\mathfrak{X} \models^{\exists V} \varphi\psi$ . Notice, however, that we gave Abelard the freedom to cheat and choose arbitrary values for  $\vec{p}$ . Thus, in principle, Eloise could be able to satisfy the property while losing the game, since Abelard can choose assignments over  $\vec{p}$  that do not belong to  $X$ . To remedy this, we add all those assignments to Eloise's winning set, thus deterring Abelard from cheating.

**CONSTRUCTION 2 (Quantification Game II).** *For a quantification-game schema  $\Omega \triangleq \langle \mathfrak{X}, \varphi, \Psi \rangle$ , we say that  $\exists$  is a  $\Omega$ -game if there is a generator  $\langle \tilde{\varphi}, X \rangle$  for  $\mathfrak{X}$  such that  $\exists \triangleq \exists \tilde{\Psi}$  where*

- $\tilde{\varphi} \triangleq \forall \vec{p}. \tilde{\varphi}. \varphi$  and
- $\tilde{\Psi} \triangleq \Psi \cup \{\chi \in \text{Asg}(P) \mid \chi \upharpoonright_{\vec{p}} \notin X\}$ ,

with  $\vec{p} \triangleq \text{ap}(\mathfrak{X}) \setminus \text{ap}(\tilde{\varphi})$  and  $P \triangleq \text{ap}(\varphi) \cup \text{ap}(\mathfrak{X})$ .

The quantification-game schema for a formula  $\varphi\psi$ , with  $\psi \in \text{LTL}$ , and a hyperassignment  $\mathfrak{X}$  is the tuple  $\Omega_{\varphi\psi}^{\mathfrak{X}} \triangleq \langle \mathfrak{X}, \varphi, L(\psi) \rangle$ . We can now generalise Theorem 4 to formulae.

**THEOREM 7 (Game-Theoretic Semantics II).**  $\mathfrak{X} \models^{\exists V} \varphi\psi$  (resp.,  $\mathfrak{X} \not\models^{\exists V} \varphi\psi$ ) iff Eloise (resp., Abelard) wins every  $\Omega_{\varphi\psi}^{\mathfrak{X}}$ -game, for all behavioural GFG-QPTL formulae  $\varphi\psi$ , with  $\psi \in \text{LTL}$ , and Borelian behavioural hyperassignments  $\mathfrak{X} \in \text{HAsg}(\text{free}(\varphi\psi))$ .



The proof of the above result follows an approach similar to the one described in the previous subsection for Theorem 4 and uses the following result, proven in Electronic Appendix C, which generalises Theorem 5 to formulae.

**Theorem 8** (Quantification Game II). *Every  $\mathcal{Q}$ -game  $\mathcal{G}$ , for some quantification-game schema  $\mathcal{Q} \triangleq \langle \mathfrak{X}, \wp, \Psi \rangle$ , satisfies the following two properties:*

- 1) *if Eloise wins then  $E \subseteq \Psi$ , for some  $E \in \text{evl}_{\exists\forall}(\mathfrak{X}, C_{\forall\exists}(\wp))$ ;*
- 2) *if Abelard wins then  $E \not\subseteq \Psi$ , for all  $E \in \text{evl}_{\exists\forall}(\mathfrak{X}, C_{\exists\forall}(\wp))$ .*

The connection between the quantification game and the satisfaction problem w.r.t. a hyperassignment is stated by the following result.

**Corollary 4** (Quantification Game II). *For every behavioural GFG-QPTL formula  $\wp\psi$ , with  $\psi \in \text{LTL}$ , and Borelian behavioural hyperassignments  $\mathfrak{X} \in \text{HAsg}(\text{free}(\wp\psi))$ , every  $\mathcal{Q}_{\wp\psi}^{\mathfrak{X}}$ -game satisfies the following two properties:*

- 1) *if Eloise (resp., Abelard) wins then  $\mathfrak{X} \models^{\exists\forall} C_{\forall\exists}(\wp)\psi$  (resp.,  $\mathfrak{X} \not\models^{\exists\forall} C_{\exists\forall}(\wp)\psi$ );*
- 2) *if  $\mathfrak{X} \models^{\exists\forall} C_{\exists\forall}(\wp)\psi$  (resp.,  $\mathfrak{X} \not\models^{\exists\forall} C_{\forall\exists}(\wp)\psi$ ) then Eloise (resp., Abelard) wins.*

PROOF. Let  $\mathcal{G}$  be an arbitrary  $\mathcal{Q}_{\wp\psi}^{\mathfrak{X}}$ -game. Item 1 immediately follows from Item 1 of Definition 3, Lemma 5 and the two items of Theorem 8. For Item 2, instead, let us assume that  $\mathfrak{X} \models^{\exists\forall} C_{\exists\forall}(\wp)\psi$  (resp.,  $\mathfrak{X} \not\models^{\exists\forall} C_{\forall\exists}(\wp)\psi$ ). Thanks to Item 1 of Definition 3 and Lemma 5, it holds that  $E \subseteq \Psi \triangleq L(\psi)$ , for some  $E \in \text{evl}_{\exists\forall}(\mathfrak{X}, C_{\exists\forall}(\wp))$  (resp.,  $E \not\subseteq \Psi$ , for all  $E \in \text{evl}_{\exists\forall}(\mathfrak{X}, C_{\forall\exists}(\wp))$ ). Thus, by Item 2 (resp., Item 1) of Theorem 8, it follows that Abelard (resp., Eloise) loses the game  $\mathcal{G}$ , which means, by determinacy, that Eloise (resp., Abelard) wins.  $\square$

Corollary 4, together with Proposition 6, lifts Theorem 6 to formulae as follows.

**Theorem 9** (Formula Canonical Forms). *For every behavioural GFG-QPTL formula  $\wp\psi$ , with  $\psi \in \text{LTL}$ , it holds that  $\mathfrak{X} \models^{\alpha} \wp\psi$  iff  $\mathfrak{X} \models^{\alpha} C_{\forall\exists}(\wp)\psi$  iff  $\mathfrak{X} \models^{\alpha} C_{\exists\forall}(\wp)\psi$ , for all Borelian behavioural hyperassignments  $\mathfrak{X} \in \text{HAsg}(\text{free}(\wp\psi))$ .*

PROOF. We focus on the statement for  $\alpha = \exists\forall$ , as the case  $\alpha = \forall\exists$  can be easily derived from the previous one by observing that, thanks to the Boolean laws of Lemma 4, (a)  $\mathfrak{X} \models^{\forall\exists} \wp\psi$  iff  $\mathfrak{X} \not\models^{\exists\forall} \bar{\wp} \neg\psi$ , (b)  $\mathfrak{X} \models^{\exists\forall} C_{\exists\forall}(\wp)\psi$  iff  $\mathfrak{X} \not\models^{\forall\exists} C_{\forall\exists}(\bar{\wp}) \neg\psi$ , and (c)  $\mathfrak{X} \models^{\forall\exists} C_{\forall\exists}(\wp)\psi$  iff  $\mathfrak{X} \not\models^{\exists\forall} C_{\exists\forall}(\bar{\wp}) \neg\psi$ . As done in the proof of Theorem 6, one chain of implication – if  $\mathfrak{X} \models^{\exists\forall} C_{\forall\exists}(\wp)\psi$  then  $\mathfrak{X} \models^{\exists\forall} \wp\psi$  and if  $\mathfrak{X} \models^{\exists\forall} \wp\psi$  then  $\mathfrak{X} \models^{\exists\forall} C_{\exists\forall}(\wp)\psi$  – is an immediate consequence of Proposition 6, Lemma 5, and Theorem 2. Indeed, by Lemma 5, we have that (1)  $\mathfrak{X} \models^{\exists\forall} \wp\psi$  iff  $\text{evl}_{\exists\forall}(\mathfrak{X}, \wp) \models^{\exists\forall} \psi$ , (2)  $\mathfrak{X} \models^{\exists\forall} C_{\exists\forall}(\wp)\psi$  iff  $\text{evl}_{\exists\forall}(\mathfrak{X}, C_{\exists\forall}(\wp)) \models^{\exists\forall} \psi$ , and (3)  $\mathfrak{X} \models^{\exists\forall} C_{\forall\exists}(\wp)\psi$  iff  $\text{evl}_{\exists\forall}(\mathfrak{X}, C_{\forall\exists}(\wp)) \models^{\exists\forall} \psi$ . Now, by Proposition 6, it holds that  $\text{evl}_{\exists\forall}(\mathfrak{X}, C_{\forall\exists}(\wp)) \sqsubseteq \text{evl}_{\exists\forall}(\mathfrak{X}, \wp) \sqsubseteq \text{evl}_{\exists\forall}(\mathfrak{X}, C_{\exists\forall}(\wp))$ . Therefore, by Theorem 2, we have that  $\mathfrak{X} \models^{\exists\forall} C_{\forall\exists}(\wp)\psi$  implies  $\mathfrak{X} \models^{\exists\forall} \wp\psi$ , which, in turn, implies  $\mathfrak{X} \models^{\exists\forall} C_{\exists\forall}(\wp)\psi$ . The converse implication – if  $\mathfrak{X} \models^{\exists\forall} C_{\exists\forall}(\wp)\psi$  then  $\mathfrak{X} \models^{\exists\forall} C_{\forall\exists}(\wp)\psi$  – is a direct consequence of Corollary 4.  $\square$

The previous theorem allows us to obtain a proof for Theorem 7.

PROOF OF THEOREM 7. Given an arbitrary  $\mathcal{Q}_{\wp\psi}^{\mathfrak{X}}$ -game  $\mathcal{G}$ , we want to prove that  $\mathfrak{X} \models^{\exists\forall} \wp\psi$  (resp.,  $\mathfrak{X} \not\models^{\exists\forall} \wp\psi$ ) holds true iff Eloise (resp., Abelard) wins  $\mathcal{G}$ . For the *if-direction*, by Item 1 of Corollary 4, if Eloise (resp., Abelard) wins  $\mathcal{G}$  then  $\mathfrak{X} \models^{\exists\forall} C_{\forall\exists}(\wp)\psi$  (resp.,  $\mathfrak{X} \not\models^{\exists\forall} C_{\exists\forall}(\wp)\psi$ ). However, this implies that  $\mathfrak{X} \models^{\exists\forall} \wp\psi$  (resp.,  $\mathfrak{X} \not\models^{\exists\forall} \wp\psi$ ), thanks to Theorem 9. For the *only-if-direction*, if  $\mathfrak{X} \models^{\exists\forall} \wp\psi$  (resp.,  $\mathfrak{X} \not\models^{\exists\forall} \wp\psi$ ) then  $\mathfrak{X} \models^{\exists\forall} C_{\exists\forall}(\wp)\psi$  (resp.,  $\mathfrak{X} \not\models^{\exists\forall} C_{\forall\exists}(\wp)\psi$ ) holds true, again due to Theorem 9. This implies, in turn, that Eloise (resp., Abelard) wins  $\mathcal{G}$ , thanks to Item 2 of Corollary 4.  $\square$

## 5 DECISION PROBLEMS, EXPRESSIVENESS & SUCCINCTNESS

The results of the previous section can be exploited to solve optimally the decision problems for behavioural GFG-QPTL. More specifically, we can use the game of Constructions 1 for the satisfiability problem, and the game of Constructions 2 for the model-checking one. We also discuss the expressiveness relationship between QPTL and behavioural GFG-QPTL, showing, by means of a classic encoding of automata into logic, that they have the same expressive power, though QPTL is non-elementarily more succinct than behavioural GFG-QPTL.

### 5.1 Decision Procedures

The first step in deciding the satisfiability problem is to derive from a behavioral sentence  $\varphi = \wp\psi$  a *parity game* [14, 65] that is won by Eloise *iff*  $\varphi$  is satisfiable. To do that, we first construct a deterministic parity automaton  $\mathcal{D}_\psi$  for the LTL formula  $\psi$ , by combining the Vardi-Wolper construction [81] with the Safra-like translation from Büchi to parity acceptance condition [69]. We then compute the synchronous product of the arena  $\mathcal{A}_\varphi$  of Construction 1 with  $\mathcal{D}_\psi$ , where the automaton component changes state only when Abelard takes a move starting from an observable position containing full valuation of the propositions. Such valuation is read by the transition function of  $\mathcal{D}_\psi$  to determine its successor state. The resulting game simulates both the quantification game and the automaton, so that Eloise wins *iff* the play satisfies  $\psi$ . This result, formally stated below, is proven in Electronic Appendix D.

**Theorem 10** (Satisfiability Game). *For every behavioral GFG-QPTL sentence  $\varphi$  there is a parity game, with  $2^{2^{\alpha(|\varphi|)}}$  positions and  $2^{\alpha(|\varphi|)}$  priorities, won by Eloise iff  $\varphi$  is satisfiable.*

We can then obtain an upper bound on the complexity of the problem from the fact that parity games can be solved in time polynomial in the number of positions and exponential in that of the priorities [13, 15, 87]. For the lower bound, instead, we observe that the *reactive synthesis problem* [72] of an LTL formula  $\psi$  can be reduced to the satisfiability of a sentence of the form  $\forall^B \vec{p}. \exists^B \vec{q}. \psi$ , where  $\vec{p}$  and  $\vec{q}$  denote, respectively, the input and output signals of the desired system.

**Theorem 11** (Satisfiability Complexity). *The satisfiability problem for behavioral GFG-QPTL sentences is 2EXPTIME-COMplete.*

As to the (*universal*) *model-checking problem*, given a Kripke structure  $\mathcal{K}$ , we ask whether  $\mathcal{K} \models \varphi$ , in the sense that  $\mathfrak{X}_{\mathcal{K}} \models^{\exists\forall} \varphi$  holds, where  $\mathfrak{X}_{\mathcal{K}} \triangleq \{\{\chi \in \text{Asg}(\text{ap}(\mathcal{K})) \mid \text{wr}d(\chi) \in L(\mathcal{K})\}\}$  is the hyperassignment obtained by collecting all the assignments  $\chi \in \text{Asg}(\text{ap}(\mathcal{K}))$  over the propositions of  $\mathcal{K}$  for which the infinite word  $\text{wr}d(\chi)$  belongs to the  $\omega$ -language  $L(\mathcal{K})$  generated by  $\mathcal{K}$ . Since  $L(\mathcal{K})$  is an  $\omega$ -regular language,  $\mathfrak{X}_{\mathcal{K}}$  is clearly a Borelian behavioral hyperassignment. As a consequence, Construction 2 applies. Thus, we can adopt the same synchronous product described above between the arena of the game and the union of the two automata  $\mathcal{D}_\psi$  and  $\mathcal{N}_{\overline{\mathcal{K}}}$ , where  $\mathcal{D}_\psi$  is obtained from the formula  $\psi$ , while  $\mathcal{N}_{\overline{\mathcal{K}}}$  is a co-safety automaton of size linear in  $|\mathcal{K}|$ , recognising the complement of  $L(\mathcal{K})$ . Observe that one may also consider the dual notion of *existential model-checking*, which asks whether  $\mathcal{K} \models \varphi$  in the sense of  $\mathfrak{X}_{\mathcal{K}} \models^{\forall\exists} \varphi$ , which can be solved analogously.

**Theorem 12** (Model-Checking Game). *For every Kripke structure  $\mathcal{K}$  and behavioral GFG-QPTL formula  $\varphi$ , with  $\text{free}(\varphi) \subseteq \text{ap}(\mathcal{K})$ , there is a parity game, with  $2^{2^{\alpha(|\varphi|)}} \cdot |\mathcal{K}|$  positions and  $2^{\alpha(|\varphi|)}$  priorities, won by Eloise iff  $\mathcal{K} \models \varphi$ .*

Upper bounds *w.r.t.* both formula and model complexity, and the lower bound *w.r.t.* formula complexity, are proved as in the case of the satisfiability problem. As far as the model complexity is concerned, the lower bound can be naturally derived by reducing from reachability games [43].

**Theorem 13** (Model-Checking Complexity). *The model-checking problem for behavioral GFG-QPTL has a 2EXPTIME-COMplete formula complexity and a PTIME-COMplete model complexity.*

## 5.2 Expressive Power

We conclude the work by discussing the expressive power of the behavioral fragment of GFG-QPTL, showing that it precisely corresponds to the  $\omega$ -regular languages. Similarly to Example 9, consider an arbitrary deterministic parity automaton  $\mathcal{D}$  with  $k$  states over an alphabet  $2^P$ , with  $P \subseteq AP$ .

Via a standard encoding of the transition function and the acceptance condition, we can construct an LTL formula  $\psi$ , over the set of propositions  $P \cup \{s_1, \dots, s_k\}$ , such that the existential projection on  $P$  of the language  $L(\psi)$  coincides with the language  $L(\mathcal{D})$  recognised by  $\mathcal{D}$ . Since  $\mathcal{D}$  is deterministic, this projection is clearly behavioral. Hence, the behavioral GFG-QPTL formula  $\exists^B s_1 \dots \exists^B s_k. \psi$  is  $\exists\forall$ -satisfied by the hyperassignment  $\{\text{wr}^{-1}(L(\mathcal{D}))\}$ . Since every QPTL formula can be translated into an equivalent nondeterministic Büchi automaton [78], which in turn can be determined into a parity one [69], we obtain that for every QPTL formula there is an equivalent behavioral GFG-QPTL formula. The converse holds as well. Indeed, the satisfiability game  $\mathcal{D}_\varphi$  can be transformed into an isomorphic alternating parity word automaton  $\mathcal{A}_\varphi$ , in the usual way, which can then be reduced to a nondeterministic parity automaton  $\mathcal{N}_\varphi$  with an exponential blow-up [66]. The emptiness of  $\mathcal{N}_\varphi$  can then be encoded into a QPTL sentence. A similar reasoning applies also to formulae.

**Theorem 14** (Expressiveness). *QPTL and behavioral GFG-QPTL are equi-expressive.*

Clearly, QPTL is also non-elementary more succinct than behavioral GFG-QPTL. Indeed, the satisfiability problem for QPTL sentences with alternation of quantifiers  $k$  is non-elementary in  $k$ , precisely  $(k - 1)$ -EXSPACE-COMplete [78], while behavioral GFG-QPTL is decidable in 2EXPTIME, so no elementary reduction exists.

**Theorem 15** (Succinctness). *QPTL is non-elementary more succinct than behavioral GFG-QPTL.*

## 6 DISCUSSION

We have introduced a novel semantics for QPTL extending in a non-trivial way Hodges' team semantics for Hintikka and Sandu's logic of imperfect information IF. On the one hand, the new semantic setting can express games with both symmetric and asymmetric restrictions on the players. On the other hand, it allows for encoding behavioral constraints on the quantified propositions, connecting the underlying logic with the game-theoretic notion of behavioral strategies. Based on this semantics, the extension of QPTL with constraints on the functional dependencies among propositions, called GFG-QPTL, has surprisingly interesting properties. For one, its behavioral fragment enables reducing the solution of two-player zero-sum games to the decision problems for the logic. Indeed, the deep connection with behavioral strategies ensures that satisfiable formulae of the logic express linear time properties that can always be realised by means of actual strategies. This fragment also enjoys good computational properties, being 2EXPTIME-COMplete for both satisfiability and model-checking. It is also very expressive, being equivalent to, though less succinct than, QPTL, hence able to describe all  $\omega$ -regular properties. Second, the behavioral semantics also bears a connection to good-for-game automata, allowing to naturally express the property of being a GFG automata, the significance of which is probably worth investigating further.

To the best of our knowledge, this is the first attempt to provide a compositional account of behavioral constraints. We believe the generality and flexibility of the semantic settings opens up the possibility of a systematic investigation of the impact of this type of constraints in quantified temporal logics, such as QCTL [20, 52], Substructure Temporal Logic [3, 4], HyperLTL/CTL\* [10, 12, 16, 17, 19], Coordination Logic [18], and Strategy Logic [9, 59, 60]. For Strategy Logic, in particular,

the known satisfiability results are limited to specific fragments and the corresponding decision procedures crucially rely on the behavioural nature of those specific fragments [2, 58]. Being able to devise a behavioural semantics for the full language could very well lead to a fully decidable version of important fragments of that logic.

## ACKNOWLEDGMENTS

The authors would like to thank the anonymous reviewers for the many suggestions which helped to considerably improve the earlier version of the manuscript.

This work was partially supported by the GNCS 2020 project “Strategic Reasoning and Automatic Synthesis of Multi-Agent Systems (Ragionamento Strategico e Sintesi Automatica di Sistemi Multi-Agente)”.

## REFERENCES

- [1] S. Abramsky, J. Kontinen, J.A. Väänänen, and H. Vollmer. 2016. *Dependence Logic: Theory and Applications*. Springer.
- [2] E. Acar, M. Benerecetti, and F. Mogavero. 2019. Satisfiability in Strategy Logic Can Be Easier than Model Checking. In *AAAI Press 19*. AAAI Press, 2638–2645.
- [3] M. Benerecetti, F. Mogavero, and A. Murano. 2013. Substructure Temporal Logic. In *Logic in Computer Science’13*. IEEE Computer Society, 368–377.
- [4] M. Benerecetti, F. Mogavero, and A. Murano. 2015. Reasoning About Substructures and Games. *Transactions On Computational Logic* 16, 3 (2015), 25:1–46.
- [5] A. Blass and Y. Gurevich. 1986. Henkin Quantifiers and Complete Problems. *Annals of Pure and Applied Logic* 32, 1 (1986), 1–16.
- [6] U. Boker and K. Lehtinen. 2019. Good for Games Automata: From Nondeterminism to Alternation. In *Concurrency Theory’19 (LIPIcs 140, Vol. 140)*. Leibniz-Zentrum fuer Informatik, 19:1–19.
- [7] S.R. Buss. 1998. *Handbook of Proof Theory*. Elsevier.
- [8] K. Chatterjee, T.A. Henzinger, and N. Piterman. 2007. Strategy Logic. In *Concurrency Theory’07 (LNCS 4703)*. Springer, 59–73.
- [9] K. Chatterjee, T.A. Henzinger, and N. Piterman. 2010. Strategy Logic. *Information and Computation* 208, 6 (2010), 677–693.
- [10] M.R. Clarkson, B. Finkbeiner, M. Koleini, K.K. Micinski, M. Rabe, and C. Sánchez. 2014. Temporal Logics for Hyperproperties. In *Principles of Security and Trust’14 (LNCS 8414)*. Springer, 265–284.
- [11] M.R. Clarkson and F.B. Schneider. 2010. Hyperproperties. *Journal of Computer Security* 18, 6 (2010), 1157–1210.
- [12] N. Coenen, B. Finkbeiner, C. Hahn, and J. Hofmann. 2019. The Hierarchy of Hyperlogics. In *Logic in Computer Science’19*. IEEE Computer Society, 1–13.
- [13] E.A. Emerson and C.S. Jutla. 1988. The Complexity of Tree Automata and Logics of Programs (Extended Abstract). In *Foundation of Computer Science’88*. IEEE Computer Society, 328–337.
- [14] E.A. Emerson and C.S. Jutla. 1991. Tree Automata, muCalculus, and Determinacy. In *Foundation of Computer Science’91*. IEEE Computer Society, 368–377.
- [15] E.A. Emerson, C.S. Jutla, and A.P. Sistla. 1993. On Model-Checking for Fragments of muCalculus. In *Computer Aided Verification’93 (LNCS 697)*. Springer, 385–396.
- [16] B. Finkbeiner and C. Hahn. 2016. Deciding Hyperproperties. In *Concurrency Theory’16 (LIPIcs 59)*. Leibniz-Zentrum fuer Informatik, 13:1–14.
- [17] B. Finkbeiner, M.N. Rabe, and C. Sánchez. 2015. Algorithms for Model Checking HyperLTL and HyperCTL\*. In *Computer Aided Verification’15 (LNCS 9206)*. Springer, 30–48.
- [18] B. Finkbeiner and S. Schewe. 2010. Coordination Logic. In *Computer Science Logic’10 (LNCS 6247)*. Springer, 305–319.
- [19] B. Finkbeiner and M. Zimmermann. 2016. The First-Order Logic of Hyperproperties. In *Symposium on Theoretical Aspects of Computer Science’17 (LIPIcs 66)*. Leibniz-Zentrum fuer Informatik, 30:1–14.
- [20] T. French. 2001. Decidability of Quantified Propositional Branching Time Logics. In *Advances in Artificial Intelligence’01 (LNCS 2256)*. Springer, 165–176.
- [21] P. Fritz and J. Goodman. 2017. Counting Impossible. *Mind* 126, 504 (2017), 1063–1108.
- [22] D. Gale and F.M. Stewart. 1953. Infinite Games with Perfect Information. In *Contributions to the Theory of Games (vol. II)*. Vol. 28. Princeton University Press, 245–266.
- [23] P. Gardy, P. Bouyer, and N. Markey. 2018. Dependences in Strategy Logic. In *Symposium on Theoretical Aspects of Computer Science’18 (LIPIcs 96)*. Leibniz-Zentrum fuer Informatik, 34:1–15.

- [24] P. Gardy, P. Bouyer, and N. Markey. 2020. Dependences in Strategy Logic. *Theoretical Computer Science* 64, 3 (2020), 467–507.
- [25] G. De Giacomo and G. Perelli. 2021. *Behavioral QLTL*. Technical Report. arXiv.
- [26] E. Grädel, W. Thomas, and T. Wilke. 2002. *Automata, Logics, and Infinite Games: A Guide to Current Research*. Springer.
- [27] E. Grädel and J.A. Väänänen. 2013. Dependence and Independence. *Studia Logica* 101, 2 (2013), 399–410.
- [28] J. Gutierrez, P. Harrenstein, and M. Wooldridge. 2013. Iterated Boolean Games. In *International Joint Conference on Artificial Intelligence'13*. International Joint Conference on Artificial Intelligence' & AAAI Press, 932–938.
- [29] J. Gutierrez, P. Harrenstein, and M. Wooldridge. 2015. Iterated Boolean Games. *Information and Computation* 242 (2015), 53–79.
- [30] H. Heikkilä and J.A. Väänänen. 1994. Reflection of Long Game Formulas. *Mathematical Logic Quarterly* 40, 3 (1994), 381–392.
- [31] L. Hella. 1989. Definability Hierarchies of Generalized Quantifiers. *Annals of Pure and Applied Logic* 43, 3 (1989), 235–271.
- [32] L. Henkin. 1961. Some Remarks on Infinitely Long Formulas. In *Infinitistic Methods'61*. Pergamon Press, 167–183.
- [33] T.A. Henzinger and N. Piterman. 2006. Solving Games Without Determinization. In *Computer Science Logic'06 (LNCS 4207)*. Springer, 395–410.
- [34] J. Hintikka. 1973. *Logic, Language-Games and Information: Kantian Themes in the Philosophy of Logic*. Oxford University Press.
- [35] J. Hintikka. 1973. Quantifiers vs. Quantification Theory. *Dialectica* 27, 3-4 (1973), 329–358.
- [36] J. Hintikka. 1997. *Lingua Universalis vs. Calculus Ratiocinator: An Ultimate Presupposition of Twentieth-Century Philosophy*. Springer.
- [37] J. Hintikka and V. Rantala. 1976. A New Approach to Infinitary Languages. *Annals of Mathematical Logic* 10, 1 (1976), 95–115.
- [38] J. Hintikka and G. Sandu. 1989. Informational Independence as a Semantical Phenomenon. In *International Congress on Logic, Methodology, and Philosophy of Science'89*. Elsevier, 571–589.
- [39] J. Hintikka and G. Sandu. 1997. Game-Theoretical Semantics. In *Handbook of Logic and Language*. North-Holland & Elsevier, 361–410.
- [40] W. Hodges. 1997. *A Shorter Model Theory*. Cambridge University Press.
- [41] W. Hodges. 1997. Compositional Semantics for a Language of Imperfect Information. *Logic Journal of the IGPL* 5, 4 (1997), 539–563.
- [42] W. Hodges. 1997. Some Strange Quantifiers. In *Structures in Logic and Computer Science: A Selection of Essays in Honor of A. Ehrenfeucht*. Springer, 51–65.
- [43] N. Immerman. 1981. Number of Quantifiers is Better Than Number of Tape Cells. *Journal of Computer and System Science* 22, 3 (1981), 384–406.
- [44] L. Kaiser. 2011. *Logic and Games on Automatic Structures - Playing with Quantifiers and Decompositions*. Springer.
- [45] B. Khoussainov and A. Nerode. 2001. *Automata Theory and Its Applications*. Birkhauser.
- [46] P.G. Kolaitis. 1985. Game Quantification. In *Handbook of Model-Theoretic Logics*. Springer, 365–421.
- [47] A. Krebs, A. Meier, J. Virtema, and M. Zimmermann. 2018. Team Semantics for the Specification and Verification of Hyperproperties. In *Mathematical Foundations of Computer Science'18 (LIPIcs 117)*. Leibniz-Zentrum fuer Informatik, 10:1–16.
- [48] D.M. Kreps, P. Milgrom, J. Roberts, and R. Wilson. 1982. Rational Cooperation in the Finitely Repeated Prisoners' Dilemma. *Journal of Economic Theory* 27, 2 (1982), 245–252.
- [49] H.W. Kuhn. 1950. Extensive Games. *Proceedings of the National Academy of Sciences* 36, 1 (1950), 570–576.
- [50] H.W. Kuhn. 1953. Extensive Games and the Problem of Information. In *Contributions to the Theory of Games (vol. II)*. Vol. 28. Princeton University Press, 193–216.
- [51] A. Kuusisto. 2015. A Double Team Semantics for Generalized Quantifiers. *Journal of Logic, Language, and Information* 24, 2 (2015), 149–191.
- [52] F. Laroussinie and N. Markey. 2014. Quantified CTL: Expressiveness and Complexity. *Logical Methods in Computer Science* 10, 4 (2014), 1–45.
- [53] K. Lorenz. 1968. Dialogspiele als Semantische Grundlage von Logikkalkülen. *Archiv für Mathematische Logik und Grundlagenforschung* 11 (1968), 32–55.
- [54] P. Lorenzen. 1961. Ein Dialogisches Konstruktivitätskriterium. In *Symposium on Foundations of Mathematics'59*. Polish Scientific Publishers, 193–200.
- [55] A.L. Mann, G. Sandu, and M. Sevenster. 2011. *Independence-Friendly Logic - A Game-Theoretic Approach*. Cambridge University Press.
- [56] A.D. Martin. 1975. Borel Determinacy. *Annals of Mathematics* 102, 2 (1975), 363–371.

- [57] A.D. Martin. 1985. A Purely Inductive Proof of Borel Determinacy. In *Recursion Theory'82 (Symposia in Pure Mathematics'42)*. American Mathematical Society and Association for Symbolic Logic, 303–308.
- [58] F. Mogavero, A. Murano, G. Perelli, and M.Y. Vardi. 2012. What Makes  $ATL^*$  Decidable? A Decidable Fragment of Strategy Logic. In *Concurrency Theory'12 (LNCS 7454)*. Springer, 193–208.
- [59] F. Mogavero, A. Murano, G. Perelli, and M.Y. Vardi. 2014. Reasoning About Strategies: On the Model-Checking Problem. *Transactions On Computational Logic* 15, 4 (2014), 34:1–42.
- [60] F. Mogavero, A. Murano, G. Perelli, and M.Y. Vardi. 2017. Reasoning About Strategies: On the Satisfiability Problem. *Logical Methods in Computer Science* 13, 1:9 (2017), 1–37.
- [61] F. Mogavero, A. Murano, and L. Sauro. 2013. On the Boundary of Behavioral Strategies. In *Logic in Computer Science'13*. IEEE Computer Society, 263–272.
- [62] F. Mogavero, A. Murano, and L. Sauro. 2014. A Behavioral Hierarchy of Strategy Logic. In *Computational Logic in Multi-Agent Systems'14 (LNCS 8624)*. Springer, 148–165.
- [63] F. Mogavero, A. Murano, and M.Y. Vardi. 2010. Reasoning About Strategies. In *Foundations of Software Technology and Theoretical Computer Science'10 (LIPIcs 8)*. Leibniz-Zentrum fuer Informatik, 133–144.
- [64] A.W. Mostowski. 1984. Regular Expressions for Infinite Trees and a Standard Form of Automata. In *Symposium on Computation Theory'84 (LNCS 208)*. Springer, 157–168.
- [65] A.W. Mostowski. 1991. *Games with Forbidden Positions*. Technical Report. University of Gdańsk, Gdańsk, Poland.
- [66] D.E. Muller and P.E. Schupp. 1995. Simulating Alternating Tree Automata by Nondeterministic Automata: New Results and New Proofs of Theorems of Rabin, McNaughton, and Safra. *Theoretical Computer Science* 141, 1-2 (1995), 69–107.
- [67] R.B. Myerson. 1991. *Game Theory: Analysis of Conflict*. Harvard University Press.
- [68] D. Perrin and J. Pin. 2004. *Infinite Words*. Elsevier.
- [69] N. Piterman. 2006. From Nondeterministic Buchi and Streett Automata to Deterministic Parity Automata. In *Logic in Computer Science'06*. IEEE Computer Society, 255–264.
- [70] A. Pnueli. 1977. The Temporal Logic of Programs. In *Foundation of Computer Science'77*. IEEE Computer Society, 46–57.
- [71] A. Pnueli. 1981. The Temporal Semantics of Concurrent Programs. *Theoretical Computer Science* 13 (1981), 45–60.
- [72] A. Pnueli and R. Rosner. 1989. On the Synthesis of a Reactive Module. In *Principles of Programming Languages'89*. Association for Computing Machinery, 179–190.
- [73] G. Sandu. 1993. On the Logic of Informational Independence and its Applications. *Journal of Philosophical Logic* 22 (1993), 29–60.
- [74] G. Sandu and J. Hintikka. 2001. Aspects of Compositionality. *Journal of Logic, Language, and Information* 10, 1 (2001), 49–61.
- [75] G. Sandu and J.A. Väänänen. 1992. Partially Ordered Connectives. *Mathematical Logic Quarterly* 38, 1 (1992), 361–372.
- [76] R. Seltén. 1975. Reexamination of the Perfectness Concept for Equilibrium Points in Extensive Games. *International Journal of Game Theory* 4, 1 (1975), 25–55.
- [77] A.P. Sistla. 1983. *Theoretical Issues in the Design and Verification of Distributed Systems*. Ph.D. Dissertation. Harvard University, Cambridge, MA, USA.
- [78] A.P. Sistla, M.Y. Vardi, and P. Wolper. 1987. The Complementation Problem for Büchi Automata with Applications to Temporal Logic. *Theoretical Computer Science* 49 (1987), 217–237.
- [79] J.A. Väänänen. 2007. *Dependence Logic: A New Approach to Independence Friendly Logic*. London Mathematical Society Student Texts, Vol. 70. Cambridge University Press.
- [80] J. van Heijenoort. 1967. *From Frege to Gödel: A Source Book in Mathematical Logic, 1879-1931*. Harvard University Press.
- [81] M.Y. Vardi and P. Wolper. 1986. An Automata-Theoretic Approach to Automatic Program Verification. In *Logic in Computer Science'86*. IEEE Computer Society, 332–344.
- [82] M.Y. Vardi and P. Wolper. 1986. Automata-Theoretic Techniques for Modal Logics of Programs. *Journal of Computer and System Science* 32, 2 (1986), 183–221.
- [83] J. Virtema, J. Hofmann, B. Finkbeiner, J. Kontinen, and F. Yang. 2021. Linear-Time Temporal Logic with Team Semantics: Expressivity and Complexity. In *Foundations of Software Technology and Theoretical Computer Science'21 (LIPIcs 213)*. Leibniz-Zentrum fuer Informatik, 52:1–17.
- [84] J. von Neumann. 1928. Zur Theorie der Gesellschaftsspiele. *Math. Ann.* 100, 1 (1928), 295–320.
- [85] J. von Neumann and O. Morgenstern. 1944. *Theory of Games and Economic Behavior*. Princeton University Press.
- [86] P. Wolfe. 1955. The Strict Determinateness of Certain Infinite Games. *Pacific Journal of Mathematics* 5 (1955), 841–847.
- [87] W. Zielonka. 1998. Infinite Games on Finitely Coloured Graphs with Applications to Automata on Infinite Trees. *Theoretical Computer Science* 200, 1-2 (1998), 135–183.

## ELECTRONIC APPENDIX

### A PROOFS OF SECTION 2

**Proposition 1.**  $\mathfrak{X} \subseteq \overline{\overline{\mathfrak{X}}}$  and  $\mathfrak{X} \equiv \overline{\overline{\mathfrak{X}}}$ , for all  $\mathfrak{X} \in \text{HAsg}$ .

**PROOF.** To begin with, we show that  $\mathfrak{X} \subseteq \overline{\overline{\mathfrak{X}}}$ . By definition of  $\overline{\overline{\mathfrak{X}}}$ , for every  $\overline{X} \in \overline{\overline{\mathfrak{X}}}$  there is a function  $\Gamma_{\overline{X}} \in \text{Chc}(\mathfrak{X})$  such that  $\overline{X} = \{\Gamma_{\overline{X}}(X) \mid X \in \mathfrak{X}\}$ . Now, consider an arbitrary  $X \in \mathfrak{X}$  and define  $\Gamma$  as:  $\Gamma(\overline{X}) = \Gamma_{\overline{X}}(X)$  for every  $\overline{X} \in \overline{\overline{\mathfrak{X}}}$ . Notice that  $\Gamma(\overline{X}) \in \overline{X}$ , for every  $\overline{X} \in \overline{\overline{\mathfrak{X}}}$ , and thus  $\Gamma \in \text{Chc}(\overline{\overline{\mathfrak{X}}})$ . Therefore, we have that  $\{\Gamma(\overline{X}) \mid \overline{X} \in \overline{\overline{\mathfrak{X}}}\} \in \overline{\overline{\mathfrak{X}}}$ . To conclude the proof, we are left to show that  $\{\Gamma(\overline{X}) \mid \overline{X} \in \overline{\overline{\mathfrak{X}}}\} = X$  holds as well. First, observe that  $\Gamma(\overline{X}) = \Gamma_{\overline{X}}(X) \in X$  holds for every  $\overline{X} \in \overline{\overline{\mathfrak{X}}}$ , implying  $\{\Gamma(\overline{X}) \mid \overline{X} \in \overline{\overline{\mathfrak{X}}}\} \subseteq X$ . In order to show the converse inclusion ( $\{\Gamma(\overline{X}) \mid \overline{X} \in \overline{\overline{\mathfrak{X}}}\} \supseteq X$ ), consider an arbitrary  $\chi \in X$  and a function  $\Gamma_{X_\chi} \in \text{Chc}(\mathfrak{X})$  such that  $\Gamma_{X_\chi}(X) = \chi$ . Let  $X_\chi \triangleq \{\Gamma_{X_\chi}(X) \mid X \in \mathfrak{X}\}$ . It holds that  $X_\chi \in \overline{\overline{\mathfrak{X}}}$ . Since  $\Gamma(X_\chi) = \Gamma_{X_\chi}(X) = \chi$ , we have that  $\chi \in \{\Gamma(\overline{X}) \mid \overline{X} \in \overline{\overline{\mathfrak{X}}}\}$  and, since  $\chi$  was chosen arbitrarily, we conclude  $\{\Gamma(\overline{X}) \mid \overline{X} \in \overline{\overline{\mathfrak{X}}}\} \supseteq X$ .

Observe that, straightforwardly,  $\mathfrak{X} \subseteq \overline{\overline{\mathfrak{X}}}$  implies  $\mathfrak{X} \sqsubseteq \overline{\overline{\mathfrak{X}}}$ .

Let us turn now to proving  $\overline{\overline{\mathfrak{X}}} \sqsubseteq \mathfrak{X}$ . Let  $\overline{X} \in \overline{\overline{\mathfrak{X}}}$ . By definition of  $\overline{\overline{\mathfrak{X}}}$ , there is a function  $\Gamma_{\overline{X}} \in \text{Chc}(\overline{\overline{\mathfrak{X}}})$  such that  $\overline{X} = \{\Gamma_{\overline{X}}(\overline{X}) \mid \overline{X} \in \overline{\overline{\mathfrak{X}}}\}$ . Towards a contradiction, assume that for every  $X \in \mathfrak{X}$  there is  $\chi_X \in X \setminus \overline{X}$ . Let us define  $\Gamma$  as  $\Gamma(X) = \chi_X$  for every  $X \in \mathfrak{X}$ . Notice that  $\Gamma \in \text{Chc}(\mathfrak{X})$ . Thus,  $\overline{X} \triangleq \{\chi_X \mid X \in \mathfrak{X}\} \in \overline{\overline{\mathfrak{X}}}$  and  $\overline{X} \cap \overline{X} = \emptyset$ . However,  $\Gamma_{\overline{X}}(\overline{X}) \in \overline{X} \cap \overline{X}$ , thus rising a contradiction.  $\square$

**Lemma 1** (Dualization). *The following equivalences hold true, for all QPTL formulae  $\varphi$  and hyperassignments  $\mathfrak{X} \in \text{HAsg}_{\subseteq}(\text{free}(\varphi))$ .*

(1) *Statements 1a and 1b are equivalent:*

- (a) *there exists a set of assignments  $X \in \mathfrak{X}$  such that  $\chi \models \varphi$ , for all assignments  $\chi \in X$ ;*
- (b) *for all sets of assignments  $X \in \overline{\overline{\mathfrak{X}}}$ , it holds that  $\chi \models \varphi$ , for some assignment  $\chi \in X$ .*

(2) *Statements 2a and 2b are equivalent:*

- (a) *for all sets of assignments  $X \in \mathfrak{X}$ , it holds that  $\chi \models \varphi$ , for some assignment  $\chi \in X$ ;*
- (b) *there exists a set of assignments  $X \in \overline{\overline{\mathfrak{X}}}$  such that  $\chi \models \varphi$ , for all assignments  $\chi \in X$ .*

**PROOF.** (1a  $\Rightarrow$  1b) By 1a, there is  $X \in \mathfrak{X}$  such that  $\chi \models \varphi$  holds for every  $\chi \in X$ . By definition of  $\overline{\overline{\mathfrak{X}}}$ , for every  $\overline{X} \in \overline{\overline{\mathfrak{X}}}$  there is  $\Gamma_{\overline{X}}$  such that  $\Gamma_{\overline{X}}(X) \in X$  and  $\overline{X} = \{\Gamma_{\overline{X}}(X) : X \in \mathfrak{X}\}$ ; by 1a,  $\Gamma_{\overline{X}}(X) \models \varphi$ ; since, in addition,  $\Gamma_{\overline{X}}(X) \in \overline{X}$ , the thesis holds.

(1b  $\Rightarrow$  1a) By 1b, for every  $\overline{X} \in \overline{\overline{\mathfrak{X}}}$  there is  $\chi_{\overline{X}} \in \overline{X}$  such that  $\chi_{\overline{X}} \models \varphi$ . Consider the function

$\Gamma \in \text{Chc}(\overline{\overline{\mathfrak{X}}})$  defined as:  $\Gamma(\overline{X}) = \chi_{\overline{X}}$ , for every  $\overline{X} \in \overline{\overline{\mathfrak{X}}}$ . By definition of  $\overline{\overline{\mathfrak{X}}}$ , we have that

$\{\Gamma(\overline{X}) : \overline{X} \in \overline{\overline{\mathfrak{X}}}\} \in \overline{\overline{\mathfrak{X}}}$ . By Proposition 1, it holds  $\overline{\overline{\mathfrak{X}}} \sqsubseteq \mathfrak{X}$ , which means that there is  $X \in \mathfrak{X}$ , with  $X \subseteq \{\Gamma(\overline{X}) : \overline{X} \in \overline{\overline{\mathfrak{X}}}\}$ . Since, by construction,  $\Gamma(\overline{X}) \models \varphi$  for every  $\overline{X} \in \overline{\overline{\mathfrak{X}}}$ , the thesis holds.

(2a  $\Leftrightarrow$  2b) By statement 1 of this lemma, we have that 1a is false if and only if 1b is false (not 1a  $\Leftrightarrow$  not 1b, for short). By instantiating, in this last equivalence,  $\varphi$  with  $\neg\varphi$ , we have 1a'  $\Leftrightarrow$  1b', where 1a' and 1b' are abbreviations for, respectively:

- for all sets of assignments  $X \in \mathfrak{X}$ , there exists an assignment  $\chi \in X$  such that  $\chi \not\models \neg\varphi$ ;

- there exists a set of assignments  $X \in \overline{\mathfrak{X}}$  such that, for all assignments  $\chi \in X$ , it holds that  $\chi \not\models \neg\varphi$ .

By applying semantics of negation, it is straightforward to see that  $1a'$  and  $1b'$  correspond to  $2a$  and  $2b$ , respectively, hence the thesis follows.  $\square$

**Lemma 2** (Boolean Connectives). *The following equivalences hold true, for all QPTL formulae  $\varphi_1$  and  $\varphi_2$  and hyperassignments  $\mathfrak{X} \in \text{HAsg}_{\subseteq}(\text{P})$ , with  $\text{P} \triangleq \text{free}(\varphi_1) \cup \text{free}(\varphi_2)$ .*

(1) *Statements 1a and 1b are equivalent:*

- (a) *there exists a set of assignments  $X \in \mathfrak{X}$  such that  $\chi \models \varphi_1 \wedge \varphi_2$ , for all assignments  $\chi \in X$ ;*
- (b) *for each bipartition  $(\mathfrak{X}_1, \mathfrak{X}_2) \in \text{par}(\mathfrak{X})$  of  $\mathfrak{X}$ , there exist an index  $i \in \{1, 2\}$  and a set of assignments  $X \in \mathfrak{X}_i$  such that  $\chi \models \varphi_i$ , for all assignments  $\chi \in X$ .*

(2) *Statements 2a and 2b are equivalent:*

- (a) *for all sets of assignments  $X \in \mathfrak{X}$ , it holds that  $\chi \models \varphi_1 \vee \varphi_2$ , for some assignment  $\chi \in X$ ;*
- (b) *there exists a bipartition  $(\mathfrak{X}_1, \mathfrak{X}_2) \in \text{par}(\mathfrak{X})$  of  $\mathfrak{X}$  such that, for all indexes  $i \in \{1, 2\}$  and sets of assignments  $X \in \mathfrak{X}_i$ , it holds that  $\chi \models \varphi_i$ , for some  $\chi \in X$ .*

PROOF. ( $1a \Rightarrow 1b$ ) Let  $X \in \mathfrak{X}$  be such that  $\chi \models \varphi_1 \wedge \varphi_2$  holds for every  $\chi \in X$  and consider an arbitrary pair  $(\mathfrak{X}_1, \mathfrak{X}_2) \in \text{par}(\mathfrak{X})$ . Since  $(\mathfrak{X}_1, \mathfrak{X}_2)$  is a partition of  $\mathfrak{X}$ , either  $X \in \mathfrak{X}_1$  or  $X \in \mathfrak{X}_2$ : in the former case, let  $i = 1$ ; in the latter, let  $i = 2$ . Since  $X \in \mathfrak{X}_i$  and  $\chi \models \varphi_i$  holds for every  $\chi \in X$ , the thesis holds.

( $1b \Rightarrow 1a$ ) Consider  $\mathring{\mathfrak{X}} = \{X \in \mathfrak{X} : \forall \chi \in X. \chi \models \varphi_1\}$  and the pair  $(\mathfrak{X}_1 \triangleq \mathring{\mathfrak{X}}, \mathfrak{X}_2 \triangleq \mathfrak{X} \setminus \mathring{\mathfrak{X}}) \in \text{par}(\mathfrak{X})$ . Observe that, by definition of  $\mathfrak{X}_1$ , there is no  $X \in \mathfrak{X}_1$  such that  $\chi \models \varphi_1$  holds for every  $\chi \in X$ . Thus, by  $1b$ , there must exist  $X \in \mathfrak{X}_2$  such that  $\chi \models \varphi_2$  holds for every  $\chi \in X$ . By definition of  $\mathfrak{X}_2$ , it also holds that  $\chi \models \varphi_1$  for every  $\chi \in X$ , hence the thesis.

( $2a \Leftrightarrow 2b$ ) By statement 1 of this lemma, we have that  $1a$  is false if and only if  $1b$  is false (*not*  $1a \Leftrightarrow$  *not*  $1b$ , for short). By instantiating, in this last equivalence,  $\varphi_1$  with  $\neg\varphi_1$  and  $\varphi_2$  with  $\neg\varphi_2$ , we have  $1a' \Leftrightarrow 1b'$ , where  $1a'$  and  $1b'$  are abbreviations for, respectively:

- for all sets of assignments  $X \in \mathfrak{X}$ , there exists an assignment  $\chi \in X$  such that  $\chi \not\models \neg\varphi_1 \wedge \neg\varphi_2$ ;
- there exists a pair of hyperassignments  $(\mathfrak{X}_1, \mathfrak{X}_2) \in \text{par}(\mathfrak{X})$  such that, for all indexes  $i \in \{1, 2\}$  and sets of assignments  $X \in \mathfrak{X}_i$ , there exists an assignment  $\chi \in X$  for which it holds that  $\chi \not\models \neg\varphi_i$ .

By applying the semantics of negation and the classical De Morgan's laws on the semantic rules, it is straightforward to see that  $1a'$  and  $1b'$  correspond to  $2a$  and  $2b$ , respectively, hence the thesis.  $\square$

**Lemma 3** (Hyperassignment Extensions). *The following equivalences hold true, for all QPTL formulae  $\varphi$ , atomic propositions  $p \in \text{AP}$ , and hyperassignments  $\mathfrak{X} \in \text{HAsg}_{\subseteq}(\text{free}(\varphi) \setminus \{p\})$ .*

(1) *Statements 1a and 1b are equivalent:*

- (a) *there exists a set of assignments  $X \in \mathfrak{X}$  such that  $\chi \models \exists p. \varphi$ , for all assignments  $\chi \in X$ ;*
- (b) *there exists a set of assignments  $X \in \text{ext}(\mathfrak{X}, p)$  such that  $\chi \models \varphi$ , for all assignments  $\chi \in X$ .*

(2) *Statements 2a and 2b are equivalent:*

- (a) *for all sets of assignments  $X \in \mathfrak{X}$ , it holds that  $\chi \models \forall p. \varphi$ , for some assignment  $\chi \in X$ ;*
- (b) *for all sets of assignments  $X \in \text{ext}(\mathfrak{X}, p)$ , it holds that  $\chi \models \varphi$ , for some assignment  $\chi \in X$ .*

PROOF. ( $1a \Rightarrow 1b$ ) Let  $X \in \mathfrak{X}$  be such that  $\chi \models \exists p. \varphi$  holds for every  $\chi \in X$ . By semantics (Def. 2, item 3a), for every  $\chi \in X$ , there is a temporal function  $f_\chi \in \mathbb{N} \rightarrow \mathbb{B}$  such that  $\chi[p \mapsto f_\chi] \models \varphi$ . Let  $F \in \text{Fnc}(\text{ap}(\mathfrak{X}))$  be such that  $F(\chi) = f_\chi$  for every  $\chi \in X$  and let  $X_F = \{\chi[p \mapsto F(\chi)] : \chi \in X\}$ . Since  $X_F \in \text{ext}(\mathfrak{X}, p)$  and  $\chi \models \varphi$  holds for every  $\chi \in X_F$ , the thesis holds.



(1b  $\Rightarrow$  1a) Let  $X_F \in \text{ext}(\mathfrak{X}, p)$  be such that  $\chi \models \varphi$  holds for every  $\chi \in X_F$ . By definition of  $\text{ext}(\mathfrak{X}, p)$ , there are  $X \in \mathfrak{X}$  and  $F \in \text{Fnc}(\text{ap}(\mathfrak{X}))$  such that  $X_F = \{\chi[p \mapsto F(\chi)] : \chi \in X\}$ . Clearly, by semantics (Def. 2, item 3a),  $\chi \models \exists p.\varphi$  holds for every  $\chi \in X$ , hence the thesis follows.

(2a  $\Leftrightarrow$  2b) By statement 1 of this lemma, we have that 1a is false if and only if 1b is false (*not 1a  $\Leftrightarrow$  not 1b*, for short). By instantiating, in this last equivalence,  $\varphi$  with  $\neg\varphi$ , we have  $1a' \Leftrightarrow 1b'$ , where  $1a'$  and  $1b'$  are abbreviations for, respectively:

- for all sets of assignments  $X \in \mathfrak{X}$ , there exists an assignment  $\chi \in X$  such that  $\chi \not\models \exists p.\neg\varphi$ ;
- for all sets of assignments  $X \in \text{ext}(\mathfrak{X}, p)$ , there exists an assignment  $\chi \in X$  such that  $\chi \not\models \neg\varphi$ .

By applying semantics of negation and duality of  $\exists$  and  $\forall$ , it is straightforward to see that  $1a'$  and  $1b'$  correspond to 2a and 2b, respectively, hence the thesis.  $\square$

Next, we prove Theorem 1. Here is the graph of dependency presenting the lemmata and propositions used for this proof, an edge meaning that the source is directly cited in the proof of the target.

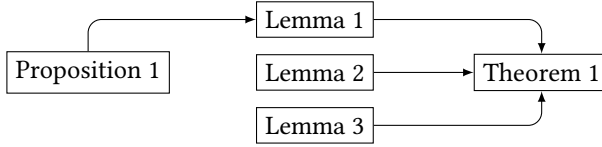

**Theorem 1** (Semantics Adequacy). *For all QPTL formulae  $\varphi$  and hyperassignments  $\mathfrak{X} \in \text{HAsg}_{\subseteq}(\text{free}(\varphi))$ :*

- (1)  $\mathfrak{X} \models^{\exists\forall} \varphi$  iff there exists a set of assignments  $X \in \mathfrak{X}$  such that  $\chi \models \varphi$ , for all assignments  $\chi \in X$ ;
- (2)  $\mathfrak{X} \models^{\forall\exists} \varphi$  iff, for all sets of assignments  $X \in \mathfrak{X}$ , it holds that  $\chi \models \varphi$ , for some assignment  $\chi \in X$ .

**PROOF.** Both claims 1 and 2 are proved together, by induction on the structure of the formula.

(base case) If  $\varphi \in \text{LTL}$ , then the claims immediately follows from the semantics (Definition 3, item 1).

(inductive step) If  $\varphi = \neg\psi$ , then we have, by semantics,  $\mathfrak{X} \models^{\alpha} \varphi$  if and only if  $\mathfrak{X} \not\models^{\bar{\alpha}} \psi$ . If  $\alpha = \exists\forall$ , then, by inductive hypothesis, it is not the case that for every  $X \in \mathfrak{X}$  there is  $\chi \in X$  such that  $\chi \models \psi$ , which amounts to say that there is  $X \in \mathfrak{X}$  such that for every  $\chi \in X$  it holds  $\chi \not\models \psi$ , from which the thesis follows. If, instead,  $\alpha = \forall\exists$ , then, by inductive hypothesis, there is no  $X \in \mathfrak{X}$  such that for every  $\chi \in X$  it holds  $\chi \models \psi$ , which amounts to say that for every  $X \in \mathfrak{X}$  there is  $\chi \in X$  such that  $\chi \not\models \psi$ , from which the thesis follows.

If  $\varphi = \varphi_1 \wedge \varphi_2$  and  $\alpha = \exists\forall$ , then we have, by semantics,  $\mathfrak{X} \models^{\alpha} \varphi$  if and only if for every  $(\mathfrak{X}_1, \mathfrak{X}_2) \in \text{par}(\mathfrak{X})$  it holds true that  $\mathfrak{X}_1 \neq \emptyset$  and  $\mathfrak{X}_1 \models^{\alpha} \varphi_1$  or it holds true that  $\mathfrak{X}_2 \neq \emptyset$  and  $\mathfrak{X}_2 \models^{\alpha} \varphi_2$ . By inductive hypothesis, this amounts to say that for every  $(\mathfrak{X}_1, \mathfrak{X}_2) \in \text{par}(\mathfrak{X})$  there is  $i \in \{1, 2\}$  and  $X \in \mathfrak{X}_i$  such that for every  $\chi \in X$  it holds  $\chi \models \varphi_i$ . The thesis follows from Lemma 2, item 1.

If  $\varphi = \varphi_1 \wedge \varphi_2$  and  $\alpha = \forall\exists$ , then we have, by semantics,  $\mathfrak{X} \models^{\alpha} \varphi$  if and only if  $\bar{\mathfrak{X}} \models^{\bar{\alpha}} \varphi$ . By proceeding as before, i.e., by applying semantics, inductive hypothesis, and Lemma 2, item 1, we have that there is  $\bar{X} \in \bar{\mathfrak{X}}$  such that for every  $\bar{\chi} \in \bar{X}$  it holds  $\bar{\chi} \models \varphi$ . The thesis follows from Lemma 1, item 2.

If  $\varphi = \varphi_1 \vee \varphi_2$  and  $\alpha = \forall\exists$ , then we have, by semantics,  $\mathfrak{X} \models^{\alpha} \varphi$  if and only if there is  $(\mathfrak{X}_1, \mathfrak{X}_2) \in \text{par}(\mathfrak{X})$  such that  $\mathfrak{X}_1 \neq \emptyset$  implies  $\mathfrak{X}_1 \models^{\alpha} \varphi_1$  and  $\mathfrak{X}_2 \neq \emptyset$  implies  $\mathfrak{X}_2 \models^{\alpha} \varphi_2$ . By inductive hypothesis, this amounts to say that there is  $(\mathfrak{X}_1, \mathfrak{X}_2) \in \text{par}(\mathfrak{X})$  such that for every  $i \in \{1, 2\}$  and  $X \in \mathfrak{X}_i$  there is  $\chi \in X$  for which it holds  $\chi \models \varphi_i$ . The thesis follows from Lemma 2, item 2.

If  $\varphi = \varphi_1 \vee \varphi_2$  and  $\alpha = \exists\forall$ , then we have, by semantics,  $\mathfrak{X} \models^\alpha \varphi$  if and only if  $\overline{\mathfrak{X}} \models^{\overline{\alpha}} \varphi$ . By proceeding as before, i.e., by applying semantics, inductive hypothesis, and Lemma 2, item 2, we have that for every  $\overline{X} \in \overline{\mathfrak{X}}$  there is  $\overline{\chi} \in \overline{X}$  such that  $\overline{\chi} \models \varphi$ . The thesis follows from Lemma 1, item 1.

If  $\varphi = \exists p.\psi$  and  $\alpha = \exists\forall$ , then we have, by semantics,  $\mathfrak{X} \models^\alpha \varphi$  if and only if  $\text{ext}(\mathfrak{X}, p) \models^\alpha \psi$ . By inductive hypothesis, this amounts to say that there is  $X \in \text{ext}(\mathfrak{X}, p)$  such that for every  $\chi \in X$  it holds  $\chi \models \psi$ . The thesis follows from Lemma 3, item 1.

If  $\varphi = \exists p.\psi$  and  $\alpha = \forall\exists$ , then we have, by semantics,  $\mathfrak{X} \models^\alpha \varphi$  if and only if  $\overline{\mathfrak{X}} \models^{\overline{\alpha}} \varphi$ . By proceeding as before, i.e., by applying semantics, inductive hypothesis, and Lemma 3, item 1, we have that there is  $\overline{X} \in \overline{\mathfrak{X}}$  such that for every  $\overline{\chi} \in \overline{X}$  it holds  $\overline{\chi} \models \varphi$ . The thesis follows from Lemma 1, item 2.

If  $\varphi = \forall p.\psi$  and  $\alpha = \forall\exists$ , then we have, by semantics,  $\mathfrak{X} \models^\alpha \varphi$  if and only if  $\text{ext}(\mathfrak{X}, p) \models^\alpha \psi$ . By inductive hypothesis, this amounts to say that for every  $X \in \text{ext}(\mathfrak{X}, p)$  there is  $\chi \in X$  such that  $\chi \models \psi$ . The thesis follows from Lemma 3, item 2.

If  $\varphi = \forall p.\psi$  and  $\alpha = \exists\forall$ , then we have, by semantics,  $\mathfrak{X} \models^\alpha \varphi$  if and only if  $\overline{\mathfrak{X}} \models^{\overline{\alpha}} \varphi$ . By proceeding as before, i.e., by applying semantics, inductive hypothesis, and Lemma 3, item 2, we have that for every  $\overline{X} \in \overline{\mathfrak{X}}$  there is  $\overline{\chi} \in \overline{X}$  such that  $\overline{\chi} \models \varphi$ . The thesis follows from Lemma 1, item 1.  $\square$

## B PROOFS OF SECTION 3

**Proposition 2.** *Let  $P \subseteq AP$  be a set of atomic propositions,  $\chi_1, \chi_2 \in \text{Asg}(P)$  two assignments,  $\Theta \in \Theta$  a quantifier specification, and  $k \in \mathbb{N}$  a time instant. Then,  $\chi_1 \approx_{\Theta}^k \chi_2$  iff the following hold true:*

- (1)  $\chi_1(q) = \chi_2(q)$ , for all  $q \in P \setminus (P_B \cup P_S)$ ;
- (2)  $\chi_1(p)(t) = \chi_2(p)(t)$ , for all  $t \leq k$  and  $p \in (P_B \cap P) \setminus P_S$ ;
- (3)  $\chi_1(p)(t) = \chi_2(p)(t)$ , for all  $t < k$  and  $p \in P_S \cap P$ .

**PROOF.** Assume  $\chi_1 \approx_{\Theta}^k \chi_2$ . Because  $\approx_{\Theta}^k$  is the transitive closure of  $\sim_{\Theta}^k$ , we have  $\chi_1 = \chi^{(1)} \sim_{\Theta}^k \chi^{(2)} \sim_{\Theta}^k \dots \sim_{\Theta}^k \chi^{(r)} = \chi_2$ , for some  $\chi^{(1)}, \dots, \chi^{(r)}$ , with  $r \in \mathbb{N} \setminus \{0\}$  (observe that  $\chi_1 = \chi_2$  if  $r = 1$ ).

We prove, by induction on  $r$ , that items 1–3 hold. If  $r = 1$ , then the claim follows trivially. Let  $r > 1$ . Since  $\chi^{(1)} \sim_{\Theta}^k \chi^{(2)}$ , we have that 1–3 hold when instantiated with  $\chi^{(1)}$  and  $\chi^{(2)}$ , by Definition 4. Moreover, by inductive hypothesis, 1–3 hold when instantiated with  $\chi^{(2)}$  and  $\chi^{(r)}$ . The claim follows by transitivity of 1–3.

Now, in order to prove the converse direction, assume that items 1–3 hold. Let  $\{p_1, \dots, p_r\}$  be an enumeration of  $P_B \cup P_S$  and define  $\chi^{(1)} \triangleq \chi_1$  and  $\chi^{(i+1)} \triangleq \chi^{(i)}[p_i \mapsto \chi_2(p_i)]$  for  $i \in [1, \dots, r]$ . It is not difficult to convince oneself that  $\chi_1 = \chi^{(1)} \sim_{\Theta}^k \chi^{(2)} \sim_{\Theta}^k \dots \sim_{\Theta}^k \chi^{(r+1)} = \chi_2$  holds, hence  $\chi_1 \approx_{\Theta}^k \chi_2$ .  $\square$

**Proposition 3.** *If  $\chi_1 \approx_{\Theta}^k \chi_2$  then  $F(\chi_1)(k) = F(\chi_2)(k)$ , for all assignments  $\chi_1, \chi_2 \in \text{Asg}(P)$ , quantifier specifications  $\Theta \in \Theta$ , time instants  $k \in \mathbb{N}$ , and  $\Theta$ -functors  $F \in \text{Fnc}_{\Theta}(P)$ .*

**PROOF.** Assume  $\chi_1 \approx_{\Theta}^k \chi_2$ , i.e.,  $\chi_1 = \chi^{(1)} \sim_{\Theta}^k \chi^{(2)} \sim_{\Theta}^k \dots \sim_{\Theta}^k \chi^{(r)} = \chi_2$ , for some  $\chi^{(1)}, \dots, \chi^{(r)}$ , with  $r \in \mathbb{N} \setminus \{0\}$  (observe that  $\chi_1 = \chi_2$  if  $r = 1$ ).

We prove, by induction on  $r$ , that  $F(\chi_1)(k) = F(\chi_2)(k)$ . If  $r = 1$ , then the claim follows trivially. Let  $r > 1$ . Since  $\chi^{(1)} \sim_{\Theta}^k \chi^{(2)}$  and  $F \in \text{Fnc}_{\Theta}(P)$ , we have that  $F(\chi^{(1)})(k) = F(\chi^{(2)})(k)$ . Moreover, by inductive hypothesis,  $F(\chi^{(2)})(k) = F(\chi^{(r)})(k)$ . The claim follows by transitivity.  $\square$

**Proposition 4.** *Let  $\mathfrak{X}_1, \mathfrak{X}_2 \in \text{HAsg}$  be two hyperassignments with  $\mathfrak{X}_1 \sqsubseteq \mathfrak{X}_2$ . Then, the following properties hold true:*

- (1)  $\overline{\mathfrak{X}_2} \sqsubseteq \overline{\mathfrak{X}_1}$ ;
- (2) for every  $(\mathfrak{X}'_2, \mathfrak{X}''_2) \in \text{par}(\mathfrak{X}_2)$ , there exists  $(\mathfrak{X}'_1, \mathfrak{X}''_1) \in \text{par}(\mathfrak{X}_1)$  such that  $\mathfrak{X}'_1 \sqsubseteq \mathfrak{X}'_2$  and  $\mathfrak{X}''_1 \sqsubseteq \mathfrak{X}''_2$ , and, in addition,  $\mathfrak{X}'_2 = \emptyset$  implies  $\mathfrak{X}'_1 = \emptyset$  and  $\mathfrak{X}''_2 = \emptyset$  implies  $\mathfrak{X}''_1 = \emptyset$ ;
- (3)  $\text{ext}_\Theta(\mathfrak{X}_1, p) \sqsubseteq \text{ext}_\Theta(\mathfrak{X}_2, p)$ , for every  $\Theta \in \Theta$  and  $p \in \text{AP}$ .

PROOF. Proof of point (1). Assume  $\mathfrak{X}_1 \sqsubseteq \mathfrak{X}_2$  and let  $\overline{X_2} \in \overline{\mathfrak{X}_2}$ . We have to show that there exists  $\overline{X_1} \in \overline{\mathfrak{X}_1}$  such that  $\overline{X_1} \subseteq \overline{X_2}$ . By  $\mathfrak{X}_1 \sqsubseteq \mathfrak{X}_2$ , there is a function  $f : \mathfrak{X}_1 \rightarrow \mathfrak{X}_2$ , such that  $f(X_1) \subseteq X_2$ . By definition of  $\overline{\mathfrak{X}_2}$ , we have that  $\overline{X_2} = \text{img}(\Gamma_2)$  for some  $\Gamma_2 \in \text{Chc}(\mathfrak{X}_2)$ .

Now, define  $\Gamma_1$  as  $\Gamma_1(X_1) \triangleq \Gamma_2(f(X_1))$  for every  $X_1 \in \mathfrak{X}_1$ . Clearly,  $\Gamma_1 \in \text{Chc}(\mathfrak{X}_1)$ , as  $\Gamma_1(X_1) = \Gamma_2(f(X_1)) \in f(X_1) \subseteq X_1$ , for each  $X_1 \in \mathfrak{X}_1$ , and thus  $\text{img}(\Gamma_1) \in \overline{\mathfrak{X}_1}$ . The thesis follows from the fact that  $\text{img}(\Gamma_1) \subseteq \text{img}(\Gamma_2) = \overline{X_2}$ .

Proof of point (2). Assume  $\mathfrak{X}_1 \sqsubseteq \mathfrak{X}_2$  and let  $(\mathfrak{X}'_2, \mathfrak{X}''_2) \in \text{par}(\mathfrak{X}_2)$ . We have to show that there exists  $(\mathfrak{X}'_1, \mathfrak{X}''_1) \in \text{par}(\mathfrak{X}_1)$  such that  $\mathfrak{X}'_1 \sqsubseteq \mathfrak{X}'_2$  and  $\mathfrak{X}''_1 \sqsubseteq \mathfrak{X}''_2$ . By  $\mathfrak{X}_1 \sqsubseteq \mathfrak{X}_2$ , there is a function  $f : \mathfrak{X}_1 \rightarrow \mathfrak{X}_2$ , such that  $f(X_1) \subseteq X_2$  for each  $X_1 \in \mathfrak{X}_1$ . Consider  $\mathfrak{X}'_1 \triangleq \{X \in \mathfrak{X}_1 \mid f(X) \in \mathfrak{X}'_2\}$  and  $\mathfrak{X}''_1 \triangleq \{X \in \mathfrak{X}_1 \mid f(X) \in \mathfrak{X}''_2\}$ . For any  $X'_1 \in \mathfrak{X}'_1$ , it holds that  $f(X'_1) \subseteq X'_1$ . By definition of  $\mathfrak{X}'_2$ , it also holds that  $f(X'_1) \in \mathfrak{X}'_2$ . Hence  $\mathfrak{X}'_1 \sqsubseteq \mathfrak{X}'_2$ . Furthermore, it is immediate to see that  $\mathfrak{X}'_2 = \emptyset \Rightarrow \mathfrak{X}'_1 = \emptyset$ . The same reasoning holds for  $\mathfrak{X}''_1 \sqsubseteq \mathfrak{X}''_2$ . Thus, the thesis is proven.

Proof of point (3). Assume  $\mathfrak{X}_1 \sqsubseteq \mathfrak{X}_2$  and let  $X'_1 \in \text{ext}_\Theta(\mathfrak{X}_1, p)$ . We have to show that there exists  $X'_2 \in \text{ext}_\Theta(\mathfrak{X}_2, p)$  such that  $X'_2 \subseteq X'_1$ . By definition of  $\text{ext}_\Theta(\mathfrak{X}_1, p)$ , we have that  $X'_1 = \text{ext}(X_1, F, p)$  for some  $X_1 \in \mathfrak{X}_1$  and  $F \in \text{Fnc}_\Theta(\text{ap}(\mathfrak{X}_1))$ . By  $\mathfrak{X}_1 \sqsubseteq \mathfrak{X}_2$  and  $X_1 \in \mathfrak{X}_1$ , we have that there is  $X_2 \in \mathfrak{X}_2$  such that  $X_2 \subseteq X_1$ .

It clearly holds that  $\text{ext}(X_2, F, p) \subseteq \text{ext}(X_1, F, p)$ . The thesis follows, since  $\text{ext}(X_2, F, p) \in \text{ext}_\Theta(\mathfrak{X}_2, p)$ .  $\square$

Next, we prove Theorem 2. Here is the graph of dependency presenting the only proposition used for this proof.



**Theorem 2** (Hyperassignment Refinement). *Let  $\varphi$  be a GFG-QPTL formula and  $\mathfrak{X}_1, \mathfrak{X}_2 \in \text{HASg}_{\subseteq}$  (free( $\varphi$ )) two hyperassignments with  $\mathfrak{X}_1 \sqsubseteq \mathfrak{X}_2$ . Then,  $\mathfrak{X}_1 \models^{\exists\forall} \varphi$  implies  $\mathfrak{X}_2 \models^{\exists\forall} \varphi$  and  $\mathfrak{X}_2 \models^{\forall\exists} \varphi$  implies  $\mathfrak{X}_1 \models^{\forall\exists} \varphi$ .*

PROOF. Assume  $\mathfrak{X}_1 \sqsubseteq \mathfrak{X}_2$ . Thus, there is a function  $f : \mathfrak{X}_1 \rightarrow \mathfrak{X}_2$ , such that  $f(X_1) \subseteq X_2$  for every  $X_1 \in \mathfrak{X}_1$ . The claim is proved by induction on the structure of the formula and the alternation flags. More precisely, we consider, as a basis for the induction, a well-founded preorder  $\leq$  over the set of pairs  $\{\langle \varphi, \alpha \rangle \mid \varphi \text{ is a GFG-QPTL formula and } \alpha \in \{\exists\forall, \forall\exists\}\}$ , such that  $\langle \varphi, \alpha \rangle \leq \langle \varphi', \alpha' \rangle$  if and only if  $\varphi$  is a subformula of  $\varphi'$  or one of the following holds:

- $\varphi = \varphi' = \psi_1 \wedge \psi_2$ ,  $\alpha = \exists\forall$ , and  $\alpha' = \forall\exists$ ,
- $\varphi = \varphi' = \psi_1 \vee \psi_2$ ,  $\alpha = \forall\exists$ , and  $\alpha' = \exists\forall$ ,
- $\varphi = \varphi' = \exists p : \Theta. \psi$ ,  $\alpha = \exists\forall$ , and  $\alpha' = \forall\exists$ ,
- $\varphi = \varphi' = \forall p : \Theta. \psi$ ,  $\alpha = \forall\exists$ , and  $\alpha' = \exists\forall$ .

(base case) If  $\varphi \in \text{LTL}$ , then the claim immediately follows from the semantics (Definition 3, item 1).

(inductive step) – ( $\varphi = \neg\psi$ ) We have, by semantics,  $\mathfrak{X}_1 \models^{\exists\forall} \varphi$  if and only if  $\mathfrak{X}_1 \not\models^{\forall\exists} \psi$ . By inductive hypothesis, this implies  $\mathfrak{X}_2 \not\models^{\forall\exists} \psi$ , which, by semantics, amounts to  $\mathfrak{X}_2 \models^{\exists\forall} \varphi$ .

On the other hand, we also have, by semantics,  $\mathfrak{X}_2 \models^{\forall\exists} \varphi$  if and only if  $\mathfrak{X}_2 \not\models^{\exists\forall} \psi$ . By inductive hypothesis, this implies  $\mathfrak{X}_1 \not\models^{\exists\forall} \psi$ , which, by semantics, amounts to  $\mathfrak{X}_1 \models^{\forall\exists} \varphi$ .

- $(\varphi = \varphi_1 \wedge \varphi_2)$  We have, by semantics,  $\mathfrak{X}_1 \models^{\exists\forall} \varphi$  if and only if for every  $(\mathfrak{X}'_1, \mathfrak{X}''_1) \in \text{par}(\mathfrak{X}_1)$  it holds true that  $\mathfrak{X}'_1 \neq \emptyset$  and  $\mathfrak{X}'_1 \models^{\exists\forall} \varphi_1$  or it holds true that  $\mathfrak{X}''_1 \neq \emptyset$  and  $\mathfrak{X}''_1 \models^{\exists\forall} \varphi_2$ . This implies that  $\mathfrak{X}_1 \neq \emptyset$  and so  $\mathfrak{X}_2 \neq \emptyset$ . Consider  $(\mathfrak{X}'_2, \mathfrak{X}''_2) \in \text{par}(\mathfrak{X}_2)$ . By Proposition 4, there exists  $(\mathfrak{X}'_1, \mathfrak{X}''_1) \in \text{par}(\mathfrak{X}_1)$  such that  $\mathfrak{X}'_1 \sqsubseteq \mathfrak{X}'_2$ ,  $\mathfrak{X}''_1 \sqsubseteq \mathfrak{X}''_2$ ,  $\mathfrak{X}'_2 = \emptyset \Rightarrow \mathfrak{X}'_1 = \emptyset$ , and  $\mathfrak{X}''_2 = \emptyset \Rightarrow \mathfrak{X}''_1 = \emptyset$ . Because  $(\mathfrak{X}'_2, \mathfrak{X}''_2) \in \text{par}(\mathfrak{X}_2)$ , it holds true that  $\mathfrak{X}'_2 \neq \emptyset$  or  $\mathfrak{X}''_2 \neq \emptyset$ . Since  $\mathfrak{X}_1 \models^{\exists\forall} \varphi$ , by inductive hypothesis, it holds true that  $\mathfrak{X}'_1 \neq \emptyset$  and  $\mathfrak{X}'_1 \models^{\exists\forall} \varphi_1$  or it holds true that  $\mathfrak{X}''_1 \neq \emptyset$  and  $\mathfrak{X}''_1 \models^{\exists\forall} \varphi_2$ . Finally, since  $\mathfrak{X}'_2 = \emptyset \Rightarrow \mathfrak{X}'_1 = \emptyset$ , if  $\mathfrak{X}'_2 = \emptyset$ , then  $\mathfrak{X}''_2 \neq \emptyset$  and  $\mathfrak{X}''_2 \models^{\exists\forall} \varphi_2$ , and, similarly, if  $\mathfrak{X}''_2 = \emptyset$ , then  $\mathfrak{X}'_2 \neq \emptyset$  and  $\mathfrak{X}'_2 \models^{\exists\forall} \varphi_1$ . So, it holds true that  $\mathfrak{X}'_2 \neq \emptyset$  and  $\mathfrak{X}'_2 \models^{\exists\forall} \varphi_1$  or it holds true that  $\mathfrak{X}''_2 \neq \emptyset$  and  $\mathfrak{X}''_2 \models^{\exists\forall} \varphi_2$ , which, by semantics, amounts to  $\mathfrak{X}_2 \models^{\exists\forall} \varphi$ .  
On the other hand, we also have, by semantics,  $\mathfrak{X}_2 \models^{\forall\exists} \varphi$  if and only if  $\overline{\mathfrak{X}}_2 \models^{\exists\forall} \varphi$ . By inductive hypothesis and Proposition 4, this implies  $\overline{\mathfrak{X}}_1 \models^{\exists\forall} \varphi$ , which, by semantics, amounts to  $\mathfrak{X}_1 \models^{\forall\exists} \varphi$ .
- $(\varphi = \varphi_1 \vee \varphi_2)$  We have, by semantics,  $\mathfrak{X}_2 \models^{\forall\exists} \varphi$  if and only if there is  $(\mathfrak{X}'_2, \mathfrak{X}''_2) \in \text{par}(\mathfrak{X}_2)$  such that  $\mathfrak{X}'_2 \neq \emptyset$  implies  $\mathfrak{X}'_2 \models^{\forall\exists} \varphi_1$  and  $\mathfrak{X}''_2 \neq \emptyset$  implies  $\mathfrak{X}''_2 \models^{\forall\exists} \varphi_2$ . By Proposition 4, there exists  $(\mathfrak{X}'_1, \mathfrak{X}''_1) \in \text{par}(\mathfrak{X}_1)$  such that  $\mathfrak{X}'_1 \sqsubseteq \mathfrak{X}'_2$ ,  $\mathfrak{X}''_1 \sqsubseteq \mathfrak{X}''_2$ ,  $\mathfrak{X}'_2 = \emptyset \Rightarrow \mathfrak{X}'_1 = \emptyset$ , and  $\mathfrak{X}''_2 = \emptyset \Rightarrow \mathfrak{X}''_1 = \emptyset$ . By inductive hypothesis,  $\mathfrak{X}'_2 \models^{\forall\exists} \varphi_1$  implies  $\mathfrak{X}'_1 \models^{\forall\exists} \varphi_1$  and  $\mathfrak{X}''_2 \models^{\forall\exists} \varphi_2$  implies  $\mathfrak{X}''_1 \models^{\forall\exists} \varphi_2$ . Therefore,  $\mathfrak{X}_1 \models^{\forall\exists} \varphi$  holds.  
On the other hand, we also have, by semantics,  $\mathfrak{X}_1 \models^{\exists\forall} \varphi$  if and only if  $\overline{\mathfrak{X}}_1 \models^{\forall\exists} \varphi$ . By inductive hypothesis and Proposition 4, this implies  $\overline{\mathfrak{X}}_2 \models^{\forall\exists} \varphi$ , which, by semantics, amounts to  $\mathfrak{X}_2 \models^{\exists\forall} \varphi$ .
- $(\varphi = \exists p : \Theta . \psi)$  We have, by semantics,  $\mathfrak{X}_1 \models^{\exists\forall} \varphi$  if and only if  $\text{ext}_{\Theta}(\mathfrak{X}_1, p) \models^{\exists\forall} \psi$ . By inductive hypothesis and Proposition 4, this implies  $\text{ext}_{\Theta}(\mathfrak{X}_2, p) \models^{\exists\forall} \psi$ , which, by semantics, amounts to  $\mathfrak{X}_2 \models^{\exists\forall} \varphi$ .  
On the other hand, we also have, by semantics,  $\mathfrak{X}_2 \models^{\forall\exists} \varphi$  if and only if  $\overline{\mathfrak{X}}_2 \models^{\exists\forall} \varphi$ . By inductive hypothesis and Proposition 4, this implies  $\overline{\mathfrak{X}}_1 \models^{\exists\forall} \varphi$ , which, by semantics, amounts to  $\mathfrak{X}_1 \models^{\forall\exists} \varphi$ .
- $(\varphi = \forall p : \Theta . \psi)$  We have, by semantics,  $\mathfrak{X}_2 \models^{\forall\exists} \varphi$  if and only if  $\text{ext}_{\Theta}(\mathfrak{X}_2, p) \models^{\forall\exists} \psi$ . By inductive hypothesis and Proposition 4, this implies  $\text{ext}_{\Theta}(\mathfrak{X}_1, p) \models^{\forall\exists} \psi$ , which, by semantics, amounts to  $\mathfrak{X}_1 \models^{\forall\exists} \varphi$ .  
On the other hand, we also have, by semantics,  $\mathfrak{X}_1 \models^{\exists\forall} \varphi$  if and only if  $\overline{\mathfrak{X}}_1 \models^{\forall\exists} \varphi$ . By inductive hypothesis and Proposition 4, this implies  $\overline{\mathfrak{X}}_2 \models^{\forall\exists} \varphi$ , which, by semantics, amounts to  $\mathfrak{X}_2 \models^{\exists\forall} \varphi$ .  $\square$

Next, we prove Theorem 3. Here is the graph of dependency presenting the lemma, proposition, corollary and theorem used for this proof. The ellipsis symbolizing dependencies already presented in a previous graph.

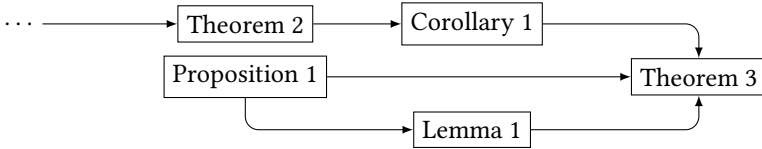

**Theorem 3** (Double Dualization). *Let  $\varphi$  be a GFG-QPTL formula and  $\mathfrak{X} \in \text{HAsg}_{\subseteq}(\text{free}(\varphi))$  a hyperassignment. Then,  $\overline{\mathfrak{X}} \models^{\alpha} \varphi$  iff  $\overline{\overline{\mathfrak{X}}} \models^{\alpha} \varphi$  iff  $\mathfrak{X} \models^{\alpha} \varphi$ .*

PROOF. The fact that

$$\mathfrak{X} \models^\alpha \varphi \text{ iff } \overline{\overline{\mathfrak{X}}} \models^\alpha \varphi \quad (\text{Thm. 3a})$$

immediately follows from  $\mathfrak{X} \equiv \overline{\overline{\mathfrak{X}}}$  (Proposition 1) and Corollary 1.

We now turn to proving that  $\mathfrak{X} \models^\alpha \varphi \text{ iff } \overline{\overline{\mathfrak{X}}} \models^\alpha \varphi$ , for all  $\mathfrak{X} \in \text{HAsg}_{\subseteq}(\text{free}(\varphi))$ . The proof is done by structural induction on the formula.

- If  $\varphi \in \text{LTL}$ , then the claim follows immediately from the semantics and Lemma 1.
- If  $\varphi = \neg\psi$ , then we have:  $\mathfrak{X} \models^\alpha \varphi \stackrel{\text{sem.}}{\Leftrightarrow} \mathfrak{X} \not\models^\alpha \psi \stackrel{\text{ind.hp.}}{\Leftrightarrow} \overline{\overline{\mathfrak{X}}} \not\models^\alpha \psi \stackrel{\text{sem.}}{\Leftrightarrow} \overline{\overline{\mathfrak{X}}} \models^\alpha \varphi$ .
- If  $\varphi = \varphi_1 \wedge \varphi_2$ , then we have:
  - $\overline{\overline{\mathfrak{X}}} \models^{\exists\forall} \varphi \stackrel{\text{sem.}}{\Leftrightarrow} \overline{\overline{\mathfrak{X}}} \models^{\exists\forall} \varphi \stackrel{\text{Thm. 3a}}{\Leftrightarrow} \mathfrak{X} \models^{\exists\forall} \varphi$ ; and
  - $\mathfrak{X} \models^{\forall\exists} \varphi \stackrel{\text{sem.}}{\Leftrightarrow} \overline{\overline{\mathfrak{X}}} \models^{\forall\exists} \varphi$ .
- If  $\varphi = \varphi_1 \vee \varphi_2$ , then we have:
  - $\mathfrak{X} \models^{\exists\forall} \varphi \stackrel{\text{sem.}}{\Leftrightarrow} \overline{\overline{\mathfrak{X}}} \models^{\exists\forall} \varphi$ ; and
  - $\overline{\overline{\mathfrak{X}}} \models^{\forall\exists} \varphi \stackrel{\text{sem.}}{\Leftrightarrow} \overline{\overline{\mathfrak{X}}} \models^{\forall\exists} \varphi \stackrel{\text{Thm. 3a}}{\Leftrightarrow} \mathfrak{X} \models^{\forall\exists} \varphi$ .
- If  $\varphi = \exists p : \Theta. \psi$ , then we have:
  - $\overline{\overline{\mathfrak{X}}} \models^{\exists\forall} \varphi \stackrel{\text{sem.}}{\Leftrightarrow} \overline{\overline{\mathfrak{X}}} \models^{\exists\forall} \varphi \stackrel{\text{Thm. 3a}}{\Leftrightarrow} \mathfrak{X} \models^{\exists\forall} \varphi$ ; and
  - $\mathfrak{X} \models^{\forall\exists} \varphi \stackrel{\text{sem.}}{\Leftrightarrow} \overline{\overline{\mathfrak{X}}} \models^{\forall\exists} \varphi$ .
- If  $\varphi = \forall p : \Theta. \psi$ , then we have:
  - $\mathfrak{X} \models^{\exists\forall} \varphi \stackrel{\text{sem.}}{\Leftrightarrow} \overline{\overline{\mathfrak{X}}} \models^{\exists\forall} \varphi$ ;
  - $\overline{\overline{\mathfrak{X}}} \models^{\forall\exists} \varphi \stackrel{\text{sem.}}{\Leftrightarrow} \overline{\overline{\mathfrak{X}}} \models^{\forall\exists} \varphi \stackrel{\text{Thm. 3a}}{\Leftrightarrow} \mathfrak{X} \models^{\forall\exists} \varphi$ .

□

**Lemma 4** (Boolean Laws). *Let  $\varphi, \varphi_1, \varphi_2$  be GFG-QPTL formulae:*

- (1)  $\varphi \equiv \neg\neg\varphi$ ;
- (2)  $\varphi_1 \wedge \varphi_2 \Rightarrow \varphi_1$ ;
- (3)  $\varphi_1 \Rightarrow \varphi_1 \vee \varphi_2$ ;
- (4)  $\varphi_1 \wedge \varphi_2 \equiv \varphi_2 \wedge \varphi_1$ ;
- (5)  $\varphi_1 \vee \varphi_2 \equiv \varphi_2 \vee \varphi_1$ ;
- (6)  $\varphi_1 \wedge (\varphi \wedge \varphi_2) \equiv (\varphi_1 \wedge \varphi) \wedge \varphi_2$ ;
- (7)  $\varphi_1 \vee (\varphi \vee \varphi_2) \equiv (\varphi_1 \vee \varphi) \vee \varphi_2$ ;
- (8)  $\varphi_1 \wedge \varphi_2 \equiv \neg(\neg\varphi_1 \vee \neg\varphi_2)$ ;
- (9)  $\varphi_1 \vee \varphi_2 \equiv \neg(\neg\varphi_1 \wedge \neg\varphi_2)$ ;
- (10)  $\exists^\Theta p. \varphi \equiv \neg(\forall^\Theta p. \neg\varphi)$ ;
- (11)  $\forall^\Theta p. \varphi \equiv \neg(\exists^\Theta p. \neg\varphi)$ .

**PROOF.** Thanks to Corollary 2, it suffices to prove the equivalence for  $\equiv^\alpha$  for some  $\alpha \in \{\exists\forall, \forall\exists\}$ . Let  $\varphi$  be a QPTL formula and  $\mathfrak{X} \in \text{HAsg}(\text{free}(\varphi))$  a hyperassignment.

- 1) From  $\mathfrak{X} \models^{\exists\forall} \neg\neg\varphi$ , applying the semantics twice leads to  $\mathfrak{X} \models^{\exists\forall} \varphi$ .
- 2) If  $\mathfrak{X} \models^{\exists\forall} \varphi_1 \wedge \varphi_2$  then by semantics, the partition  $(\mathfrak{X}_1 \triangleq \mathfrak{X}, \mathfrak{X}_2 \triangleq \emptyset)$  proves that  $\mathfrak{X} \models^{\exists\forall} \varphi_1$ .
- 3) If  $\mathfrak{X} \models^{\forall\exists} \varphi_1$  then, by considering the partition  $(\mathfrak{X}_1 \triangleq \mathfrak{X}, \mathfrak{X}_2 \triangleq \emptyset)$  it follows that  $\mathfrak{X} \models^{\forall\exists} \varphi_1 \vee \varphi_2$ .
- 4-5) Remark that if  $(\mathfrak{X}_1, \mathfrak{X}_2) \in \text{par}(\mathfrak{X})$ , then  $(\mathfrak{X}_2, \mathfrak{X}_1) \in \text{par}(\mathfrak{X})$ .
- 6-7) Remark that every 3-partition can be obtained by bi-partitioning twice. Furthermore, the second partitioning can be performed on the first part or the second part equivalently. Thus, by applying this idea to the semantics rules, the two points hold.
- 8) By semantics,  $\mathfrak{X} \models^{\exists\forall} \varphi_1 \wedge \varphi_2$  means that for all partition  $(\mathfrak{X}_1, \mathfrak{X}_2) \in \text{par}(\mathfrak{X})$  it holds  $(\mathfrak{X}_1 \neq \emptyset$  and  $\mathfrak{X}_1 \models^{\exists\forall} \varphi_1)$  or  $(\mathfrak{X}_2 \neq \emptyset$  and  $\mathfrak{X}_2 \models^{\exists\forall} \varphi_2)$ . Then, by applying 1) and the semantics rule of negation consecutively in each term of the disjunction, it results that for all  $(\mathfrak{X}_1, \mathfrak{X}_2) \in \text{par}(\mathfrak{X})$

it holds  $(\mathfrak{X}_1 \neq \emptyset \text{ and } \mathfrak{X}_1 \models^{\forall\exists} \neg\varphi_1)$  or  $(\mathfrak{X}_2 \neq \emptyset \text{ and } \mathfrak{X}_2 \models^{\forall\exists} \neg\varphi_2)$  which is the semantic of  $\mathfrak{X} \models^{\forall\exists} \neg\varphi_1 \vee \neg\varphi_2$ , hence  $\mathfrak{X} \models^{\exists\forall} \neg(\neg\varphi_1 \vee \neg\varphi_2)$ . Since all transformations are equivalences, the reverse path holds.

- 9) By semantics,  $\mathfrak{X} \models^{\forall\exists} \varphi_1 \vee \varphi_2$  means that there is a partition  $(\mathfrak{X}_1, \mathfrak{X}_2) \in \text{par}(\mathfrak{X})$  such that  $(\mathfrak{X}_1 \neq \emptyset \text{ implies } \mathfrak{X}_1 \models^{\forall\exists} \varphi_1)$  and  $(\mathfrak{X}_2 \neq \emptyset \text{ implies } \mathfrak{X}_2 \models^{\forall\exists} \varphi_2)$ . Then, by applying 1) and the semantics rule of negation consecutively in each term of the conjunction, it results that there is  $(\mathfrak{X}_1, \mathfrak{X}_2) \in \text{par}(\mathfrak{X})$  such that  $(\mathfrak{X}_1 \neq \emptyset \text{ implies } \mathfrak{X}_1 \models^{\exists\forall} \neg\varphi_1)$  and  $(\mathfrak{X}_2 \neq \emptyset \text{ implies } \mathfrak{X}_2 \models^{\exists\forall} \neg\varphi_2)$  which is the semantics for  $\mathfrak{X} \models^{\exists\forall} \neg\varphi_1 \wedge \neg\varphi_2$ , hence  $\mathfrak{X} \models^{\forall\exists} \neg(\neg\varphi_1 \wedge \neg\varphi_2)$ . Since all transformations are equivalences, the reverse path holds.
- 10) By semantics,  $\mathfrak{X} \models^{\exists\forall} \exists p: \Theta. \psi$  means that  $\text{ext}_\Theta(\mathfrak{X}, p) \models^{\exists\forall} \psi$ . Then by applying the point 1) and the semantics rule for negation consecutively, it results that  $\text{ext}_\Theta(\mathfrak{X}, p) \not\models^{\forall\exists} \neg\psi$ . We now introduce the universal quantifier using the semantics rule associated and obtain  $\mathfrak{X} \not\models^{\forall\exists} \forall p: \Theta. \neg\psi$  which is the semantics for  $\mathfrak{X} \models^{\exists\forall} \neg\forall p: \Theta. \neg\psi$ . Since all transformations are equivalences, the reverse path holds.
- 11) By semantics,  $\mathfrak{X} \models^{\forall\exists} \forall p: \Theta. \psi$  means that  $\text{ext}_\Theta(\mathfrak{X}, p) \models^{\forall\exists} \psi$ . Then by applying the point 1) and the semantics rule for negation consecutively, it results that  $\text{ext}_\Theta(\mathfrak{X}, p) \not\models^{\exists\forall} \neg\psi$ . We now introduce the existential quantifier using the semantics rule associated and obtain  $\mathfrak{X} \not\models^{\exists\forall} \exists p: \Theta. \neg\psi$  which is the semantics for  $\mathfrak{X} \models^{\forall\exists} \neg\exists p: \Theta. \neg\psi$ . Since all transformations are equivalences, the reverse path holds.  $\square$

**Proposition 5.** *Let  $\mathfrak{X}_1, \mathfrak{X}_2 \in \text{HAsg}$  be two hyperassignments with  $\mathfrak{X}_1 \sqsubseteq \mathfrak{X}_2$  and  $\varphi \in \text{Qn}$ . Then, the following holds true:  $\text{evl}_\alpha(\mathfrak{X}_1, \varphi) \sqsubseteq \text{evl}_\alpha(\mathfrak{X}_2, \varphi)$ .*

PROOF. The proof proceeds by induction on the length of the quantification prefix  $\varphi$ .

(base case) If  $\varphi = \varepsilon$ , then we have  $\text{evl}_\alpha(\mathfrak{X}_1, \varphi) = \mathfrak{X}_1 \sqsubseteq \mathfrak{X}_2 = \text{evl}_\alpha(\mathfrak{X}_2, \varphi)$ .

(inductive step) If  $\varphi = Q^\Theta p. \varphi'$ , then we distinguish two cases.

- If  $\alpha$  and  $Q$  are coherent, then we have  $\text{evl}_\alpha(\mathfrak{X}_1, \varphi) = \text{evl}_\alpha(\text{ext}_\Theta(\mathfrak{X}_1, p), \varphi')$  and  $\text{evl}_\alpha(\mathfrak{X}_2, \varphi) = \text{evl}_\alpha(\text{ext}_\Theta(\mathfrak{X}_2, p), \varphi')$ . By Proposition 4,  $\mathfrak{X}_1 \sqsubseteq \mathfrak{X}_2$  implies  $\text{ext}_\Theta(\mathfrak{X}_1, p) \sqsubseteq \text{ext}_\Theta(\mathfrak{X}_2, p)$  and, by inductive hypothesis,  $\text{evl}_\alpha(\text{ext}_\Theta(\mathfrak{X}_1, p), \varphi') \sqsubseteq \text{evl}_\alpha(\text{ext}_\Theta(\mathfrak{X}_2, p), \varphi')$ , hence the thesis.
- If  $\alpha$  and  $Q$  are not coherent, then we have  $\text{evl}_\alpha(\mathfrak{X}_1, \varphi) = \text{evl}_\alpha(\overline{\text{ext}_\Theta(\mathfrak{X}_1, p)}, \varphi')$  and  $\text{evl}_\alpha(\mathfrak{X}_2, \varphi) = \text{evl}_\alpha(\overline{\text{ext}_\Theta(\mathfrak{X}_2, p)}, \varphi')$ . By Proposition 4,  $\mathfrak{X}_1 \sqsubseteq \mathfrak{X}_2$  implies  $\overline{\text{ext}_\Theta(\mathfrak{X}_1, p)} \sqsubseteq \overline{\text{ext}_\Theta(\mathfrak{X}_2, p)}$ , and, by inductive hypothesis,  $\text{evl}_\alpha(\overline{\text{ext}_\Theta(\mathfrak{X}_1, p)}, \varphi') \sqsubseteq \text{evl}_\alpha(\overline{\text{ext}_\Theta(\mathfrak{X}_2, p)}, \varphi')$ , hence the thesis.  $\square$

**Lemma 5 (Prefix Evolution).** *Let  $\varphi\phi$  be a GFG-QPTL formula with quantifier prefix  $\varphi \in \text{Qn}$ . Then,  $\mathfrak{X} \models^\alpha \varphi\phi$  iff  $\text{evl}_\alpha(\mathfrak{X}, \varphi) \models^\alpha \phi$ , for all hyperassignments  $\mathfrak{X} \in \text{HAsg}(\text{free}(\varphi\phi))$ .*

PROOF. The proof is done by induction on the quantifier prefix  $\varphi$ .

(base case) If  $\varphi = \varepsilon$  the claim is trivial.

(inductive step) If  $\varphi = \exists^\Theta p. \varphi'$ :

- If  $\alpha$  is coherent with the first quantifier ( $\alpha = \exists\forall$ ) then by semantics rule,  $\mathfrak{X} \models^{\exists\forall} \exists^\Theta p. \varphi'. \psi \Leftrightarrow \text{ext}_\Theta(\mathfrak{X}, p) \models^{\exists\forall} \varphi'. \psi$ . We can apply the inductive hypothesis with  $\text{ext}_\Theta(\mathfrak{X}, p)$  resulting in  $\text{evl}_{\exists\forall}(\text{ext}_\Theta(\mathfrak{X}, p), \varphi') \models^{\exists\forall} \psi$  which, by definition of the operator  $\text{evl}$  results in  $\text{evl}_{\exists\forall}(\mathfrak{X}, \exists^\Theta p. \varphi') \models^{\exists\forall} \psi$ .
- If  $\alpha$  is not coherent with the first quantifier ( $\alpha = \forall\exists$ ) then by semantics rule twice,  $\mathfrak{X} \models^{\forall\exists} \exists^\Theta p. \varphi'. \psi \Leftrightarrow \overline{\mathfrak{X}} \models^{\exists\forall} \exists^\Theta p. \varphi'. \psi \Leftrightarrow \text{ext}_\Theta(\overline{\mathfrak{X}}, p) \models^{\exists\forall} \varphi'. \psi$ . By Theorem 3,  $\text{ext}_\Theta(\overline{\mathfrak{X}}, p) \models^{\forall\exists} \psi$

$\wp'. \psi$  and then, by inductive hypothesis,  $\text{evl}_{\forall\exists}(\overline{\text{ext}_{\Theta}(\overline{\mathfrak{X}}, p)}, \wp') \models^{\forall\exists} \psi$ . Finally, by definition of  $\text{evl}$  operator,  $\text{evl}_{\forall\exists}(\mathfrak{X}, \exists^{\Theta} p. \wp') \models^{\forall\exists} \psi$ .

If  $\wp = \forall^{\Theta} p. \wp'$ , the proofs when  $\alpha$  is coherent with the first quantifier and when it is not are the same as the first inductive case (by replacing  $\forall\exists$  with  $\exists\forall$  and *vice versa*).  $\square$

## C PROOFS OF SECTION 4

Now, we showcase the graph of dependency for Theorem 4, presenting the lemma, corollary and theorem used for the proof in the main paper.

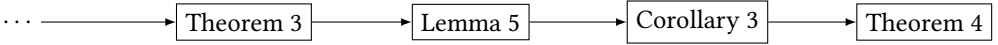

In order to provide the missing proofs of Theorems 5 and 8 and Proposition 6, in this appendix we shall also need to prove the auxiliary Propositions 7, 8, 9, 10, 11, 12, 13, and 14 and to introduce, later on, the notion of *normal evolution function* and a refinement of the order between hyperassignments.

**Proposition 7.** *Let  $\mathfrak{X} \in \text{HAsg}(\mathbb{P})$  be a hyperassignment over  $\mathbb{P} \subseteq \text{AP}$ ,  $\Theta \in \Theta$  a quantifier specification,  $p \in \text{AP} \setminus \mathbb{P}$  an atomic proposition, and  $\Psi \subseteq \text{Asg}(\mathbb{P} \cup \{p\})$  a set of assignments. There exists a set of assignments  $W \in \text{evl}_{\alpha}(\mathfrak{X}, Q^{\Theta} p)$  such that  $W \subseteq \Psi$  iff the following conditions hold true:*

- 1) *there exist  $F \in \text{Fnc}_{\Theta}(\mathbb{P})$  and  $X \in \mathfrak{X}$  such that  $\text{ext}(X, F, p) \subseteq \Psi$ , whenever  $\alpha$  and  $Q$  are coherent;*
- 2) *for all  $F \in \text{Fnc}_{\Theta}(\mathbb{P})$ , there is  $X \in \mathfrak{X}$  such that  $\text{ext}(X, F, p) \subseteq \Psi$ , whenever  $\alpha$  and  $Q$  are not coherent.*

PROOF. We consider the two conditions separately.

- [1] If  $\alpha$  and  $Q$  are coherent, by definition of evolution function, we have

$$\text{evl}_{\alpha}(\mathfrak{X}, Q^{\Theta} p) = \text{ext}_{\Theta}(\mathfrak{X}, p) = \{\text{ext}(X, F, p) \mid X \in \mathfrak{X}, F \in \text{Fnc}_{\Theta}(\text{ap}(\mathfrak{X}))\}.$$

Thus, for every set of assignments  $W \subseteq \text{Asg}(\mathbb{P} \cup \{p\})$ , it holds that  $W \in \text{evl}_{\alpha}(\mathfrak{X}, Q^{\Theta} p)$  iff there exists a  $\Theta$ -functor  $F \in \text{Fnc}_{\Theta}(\mathbb{P})$  and a set of assignments  $X \in \mathfrak{X}$  such that  $W = \text{ext}(X, F, p)$ . Hence, Condition 1 immediately follows.

- [2] If  $\alpha$  and  $Q$  are not coherent, by definition of evolution function, we have

$$\text{evl}_{\alpha}(\mathfrak{X}, Q^{\Theta} p) = \overline{\text{ext}_{\Theta}(\overline{\mathfrak{X}}, p)} = \left\{ \text{img}(\Gamma) \mid \Gamma \in \text{Chc}\left(\text{ext}_{\Theta}(\overline{\mathfrak{X}}, p)\right) \right\}.$$

Thus, for every set of assignments  $W \subseteq \text{Asg}(\mathbb{P} \cup \{p\})$ , it holds that  $W \in \text{evl}_{\alpha}(\mathfrak{X}, Q^{\Theta} p)$  iff there exists a choice function  $\Gamma \in \text{Chc}\left(\text{ext}_{\Theta}(\overline{\mathfrak{X}}, p)\right)$  such that  $W = \text{img}(\Gamma) = \left\{ \Gamma(Z) \mid Z \in \text{ext}_{\Theta}(\overline{\mathfrak{X}}, p) \right\}$ .

This means that  $W \subseteq \Psi$  iff  $\Gamma(Z) \in \Psi$ , for all  $Z \in \text{ext}_{\Theta}(\overline{\mathfrak{X}}, p)$ . Now, it is clear that there exists a choice function  $\Gamma \in \text{Chc}\left(\text{ext}_{\Theta}(\overline{\mathfrak{X}}, p)\right)$  such that  $\Gamma(Z) \in \Psi$ , for all  $Z \in \text{ext}_{\Theta}(\overline{\mathfrak{X}}, p)$

iff, for every  $Z \in \text{ext}_{\Theta}(\overline{\mathfrak{X}}, p) = \left\{ \text{ext}(Y, F, p) \mid Y \in \overline{\mathfrak{X}}, F \in \text{Fnc}_{\Theta}(\mathbb{P}) \right\}$ , there exists  $\chi_Z \in Z$  such that  $\chi_Z \in \Psi$ . The latter property, however, means that, for every  $F \in \text{Fnc}_{\Theta}(\mathbb{P})$  and  $Y \in \overline{\mathfrak{X}} = \left\{ \text{img}(\Lambda) \mid \Lambda \in \text{Chc}(\overline{\mathfrak{X}}) \right\}$ , there exists  $\chi_{F,Y} \in \text{ext}(Y, F, p)$  such that  $\chi_{F,Y} \in \Psi$ , which in turn can be written as, for every  $F \in \text{Fnc}_{\Theta}(\mathbb{P})$  and  $\Lambda \in \text{Chc}(\overline{\mathfrak{X}})$ , there exists  $\chi_{F,\Lambda} \in \text{ext}(\text{img}(\Lambda), F, p) = \text{ext}(\{\Lambda(X) \mid X \in \overline{\mathfrak{X}}\}, F, p)$  such that  $\chi_{F,\Lambda} \in \Psi$ . Now, notice that  $\chi_{F,\Lambda} \in \text{ext}(\{\Lambda(X) \mid X \in \overline{\mathfrak{X}}\}, F, p)$  iff there exists  $X \in \overline{\mathfrak{X}}$  such that  $\chi_{F,\Lambda} = \text{ext}(\Lambda(X), F, p)$ .

Thus, up to this point, we have shown that the following two properties are equivalent:

- there exists  $W \in \text{evl}_{\alpha}(\mathfrak{X}, Q^{\Theta} p)$  such that  $W \subseteq \Psi$ ;
- for all  $F \in \text{Fnc}_{\Theta}(\mathbb{P})$  and  $\Lambda \in \text{Chc}(\overline{\mathfrak{X}})$ , there exists  $X \in \overline{\mathfrak{X}}$  such that  $\text{ext}(\Lambda(X), F, p) \in \Psi$ .

Now, by deHerbrandizing<sup>3</sup> the universal quantification of  $\Lambda$  w.r.t. the existential quantification of  $X$  in the last item and recalling that  $\Lambda(X) \in X$ , we obtain that, for all  $F \in \text{Fnc}_\Theta(P)$ , there exists  $X \in \mathfrak{X}$  such that  $\text{ext}(\chi, F, p) \in \Psi$ , for all  $\chi \in X$ . But this means that, for all  $F \in \text{Fnc}_\Theta(P)$ , there exists  $X \in \mathfrak{X}$  such that  $\text{ext}(X, F, p) \subseteq \Psi$ , as required by Condition 2.  $\square$

Next, we prove Theorem 5. Here is the graph of dependency presenting the proposition used for the proof in the main paper.



**Theorem 5** (Quantification Game I). *For each behavioural quantification prefix  $\wp \in \text{Qn}_B$  and Borelian property  $\Psi \subseteq \text{Asg}(\text{ap}(\wp))$ , the game  $\mathcal{D}_\wp^\Psi$  satisfies the following two properties:*

- 1) *if Eloise wins then  $E \subseteq \Psi$ , for some  $E \in \text{evl}_{\exists\forall}(\text{C}_{\forall\exists}(\wp))$ ;*
- 2) *if Abelard wins then  $E \not\subseteq \Psi$ , for all  $E \in \text{evl}_{\exists\forall}(\text{C}_{\forall\exists}(\wp))$ .*

PROOF. Let  $\mathcal{D}_\wp^\Psi$  be the game defined as prescribed in Construction 1. Obviously, this is a Borelian game, due to the hypothesis on the property  $\Psi$ .

Before continuing, first observe that, thanks to the specific structure of the game, every history  $\rho \cdot v \in \text{Hst}_\alpha$  is bijectively correlated with the sequence of positions  $\text{obs}(\rho) \cdot v \in \text{Ob}^* \cdot \text{Ps}_\alpha$ , for any player  $\alpha \in \{E, A\}$ . In other words, the functions  $J_\alpha: \text{Hst}_\alpha \rightarrow \text{Ob}^* \cdot \text{Ps}_\alpha$  defined as  $J_\alpha(\rho \cdot v) \triangleq \text{obs}(\rho) \cdot v$  are bijective. Thanks to this observation, it is thus immediate to show that, for each strategy  $\sigma_E \in \text{Str}_E$ , there is a unique function  $\widehat{\sigma}_E: \text{Ob}^* \cdot \text{Ps}_E \rightarrow \text{Ps}$  and, *vice versa*, for each function  $\widehat{\sigma}_E: \text{Ob}^* \cdot \text{Ps}_E \rightarrow \text{Ps}$ , there is a unique strategy  $\sigma_E \in \text{Str}_E$  such that

$$\widehat{\sigma}_E(J_E(\rho)) = \sigma_E(\rho), \text{ for all histories } \rho \in \text{Hst}_E.$$

Similarly, for each strategy  $\sigma_A \in \text{Str}_A$ , there is a unique function  $\widehat{\sigma}_A: \text{Ob}^* \cdot \text{Ps}_A \rightarrow \text{Ps}$  and, *vice versa*, for each function  $\widehat{\sigma}_A: \text{Ob}^* \cdot \text{Ps}_A \rightarrow \text{Ps}$ , there is a unique strategy  $\sigma_A \in \text{Str}_A$  satisfying the equality

$$\widehat{\sigma}_A(J_A(\rho)) = \sigma_A(\rho), \text{ for all histories } \rho \in \text{Hst}_A.$$

We can now proceed with the proof of the two properties.

- [1] Since Eloise wins the game, she has a winning strategy, *i.e.*, there is  $\sigma_E \in \text{Str}_E$  such that  $\text{obs}(\text{play}(\sigma_E, \sigma_A)) \in \text{Wn}$ , for all  $\sigma_A \in \text{Str}_A$ . We want to prove that there exists  $E \in \text{evl}_{\exists\forall}(\text{C}_{\forall\exists}(\wp))$  such that  $E \subseteq \Psi$ .

First, recall that  $\text{C}_{\forall\exists}(\wp) = \forall^B \vec{p}. \exists^{\vec{\Theta}} \vec{q}$ , for some vectors of atomic propositions  $\vec{p}, \vec{q} \in \text{AP}^*$  and quantifier specifications  $\vec{\Theta} \in \Theta^{|\vec{q}|}$ . Moreover, thanks to Proposition 7, the following claim can be proved by induction on the number of existential variables.

**Claim 1.**  $E \subseteq \Psi$ , for some  $E \in \text{evl}_{\exists\forall}(\text{C}_{\forall\exists}(\wp))$ , iff there exists a vector of functors  $\vec{F} \in \text{Fnc}_\Theta(\vec{p})$  such that  $\text{ext}(\chi, \vec{F}, \vec{q}) \in \Psi$ , for all assignments  $\chi \in \text{Asg}(\vec{p})$ .

PROOF. As previously observed,  $\text{C}_{\forall\exists}(\wp) = \forall^B \vec{p}. \exists^{\vec{\Theta}} \vec{q}$ , for some vectors  $\vec{p}, \vec{q} \in \text{AP}^*$  and  $\vec{\Theta} \in \Theta^{|\vec{q}|}$ . Thus,  $\text{evl}_{\exists\forall}(\text{C}_{\forall\exists}(\wp)) = \text{evl}_{\exists\forall}(\forall^B \vec{p}. \exists^{\vec{\Theta}} \vec{q}) = \text{evl}_{\exists\forall}(\text{evl}_{\exists\forall}(\forall^B \vec{p}), \exists^{\vec{\Theta}} \vec{q}) = \text{evl}_{\exists\forall}(\{\text{Asg}(\vec{p})\}, \exists^{\vec{\Theta}} \vec{q})$ . At this point, the proof proceeds by induction on the length of the vector  $\vec{q}$ . If  $|\vec{q}| = 0$ , there is nothing really to prove, as the thesis follows immediately from the fact that  $\text{evl}_{\exists\forall}(\text{C}_{\forall\exists}(\wp)) = \{\text{Asg}(\vec{p})\}$ . Let us now consider the case  $|\vec{q}| > 0$  and split both  $\vec{q}$  and  $\vec{\Theta}$  as follows:  $\vec{q} = \vec{q}' \cdot q$  and

<sup>3</sup>The Herbrandization process [7, 80] is the dual of the well known Skolemization process and transforms a logic formula of the form  $\exists x \forall y. \psi(x, y)$  into the equivalent (higher-order) formula  $\forall F \exists x. \psi(x, F(x))$ , where  $F$  is the *Herbrand function* for the universally-quantified variable  $y$ . The deHerbrandizing process is the inverse transformation from  $\forall F \exists x. \psi(x, F(x))$  to  $\exists x \forall y. \psi(x, y)$ . Note that here the process is applied at the meta level of the proof.



$\vec{\Theta} = \vec{\Theta}' \cdot \Theta$ . Obviously,  $\text{evl}_{\exists\forall}(\text{C}_{\forall\exists}(\varphi)) = \text{evl}_{\exists\forall}(\text{evl}_{\exists\forall}(\{\text{Asg}(\vec{p})\}, \exists\vec{\Theta}' \vec{q}', \exists\Theta q))$ . Now, by Item 1 of Proposition 7,  $E \subseteq \Psi$ , for some  $E \in \text{evl}_{\exists\forall}(\text{C}_{\forall\exists}(\varphi))$ , iff there exist a functor  $F \in \text{Fnc}_{\Theta}(\vec{p} \cdot \vec{q}')$  and a set  $X \in \text{evl}_{\exists\forall}(\{\text{Asg}(\vec{p})\}, \exists\vec{\Theta}' \vec{q}')$  such that  $\text{ext}(X, F, q) \subseteq \Psi$ . The latter inclusion can be rewritten as  $X \subseteq \text{prj}(\Psi, F, q)$ , where  $\text{prj}(\Psi, F, q) \triangleq \{\chi \in \text{Asg}(\vec{p} \cdot \vec{q}') \mid \text{ext}(\chi, F, q) \subseteq \Psi\}$ . At this point, by the inductive hypothesis applied to the inclusion  $X \subseteq \text{prj}(\Psi, F, q)$ , for some  $X \in \text{evl}_{\exists\forall}(\{\text{Asg}(\vec{p})\}, \exists\vec{\Theta}' \vec{q}')$ , we obtain that  $E \subseteq \Psi$ , for some  $E \in \text{evl}_{\exists\forall}(\text{C}_{\forall\exists}(\varphi))$ , iff there exist a functor  $F \in \text{Fnc}_{\Theta}(\vec{p} \cdot \vec{q}')$  and a vector of functors  $\vec{F}' \in \text{Fnc}_{\vec{\Theta}' }(\vec{p})$  such that  $\text{ext}(\text{Asg}(\vec{p}), \vec{F}', \vec{q}') \subseteq \text{prj}(\Psi, F, q)$ . The latter inclusion can now be rewritten as  $\text{ext}(\text{ext}(\text{Asg}(\vec{p}), \vec{F}', \vec{q}'), F, q) \subseteq \Psi$ . To conclude the proof, the vector of functors  $\vec{F} \in \text{Fnc}_{\vec{\Theta}}(\vec{p})$  is obtained by juxtaposing the vector  $\vec{F}'$  with the functor  $F^* \in \text{Fnc}_{\Theta}(\vec{p})$  obtained by composing  $F$  with  $\vec{F}'$  as follows:  $F^*(\chi) \triangleq F(\text{ext}(\chi, \vec{F}', \vec{q}'))$ .  $\square$

Due to the above characterisation of the existence of a set  $E \in \text{evl}_{\exists\forall}(\text{C}_{\forall\exists}(\varphi))$  such that  $E \subseteq \Psi$ , the thesis can be proved by defining a suitable vector of functors  $\vec{F} \in \text{Fnc}_{\vec{\Theta}}(\vec{p})$ . Consider an arbitrary assignment  $\chi \in \text{Asg}(\vec{p})$  and define the function  $\widehat{\sigma}_A^\chi: \text{Ob}^* \cdot \text{Ps}_A \rightarrow \text{Ps}$  as follows, for all finite sequences of observable positions  $w \in \text{Ob}^*$  and Abelard's positions  $\xi \in \text{Ps}_A$ :

$$\widehat{\sigma}_A^\chi(w \cdot \xi) \triangleq \begin{cases} \emptyset, & \text{if } \xi \in \text{Ob}; \\ \xi[x \mapsto \chi(x)(|w|)], & \text{otherwise;} \end{cases}$$

where  $x \in \vec{p}$  is the atomic proposition at position  $\#(\xi)$  in the prefix  $\varphi$ , i.e.,  $(\varphi)_{\#(\xi)} = \forall^B x$ . Due to the bijective correspondence previously described, there is a unique strategy  $\sigma_A^\chi \in \text{Str}_A$  such that  $\sigma_A^\chi(\rho) = \widehat{\sigma}_A^\chi(J_A(\rho))$ , for all histories  $\rho \in \text{Hst}_A$ . Obviously, the induced play  $\pi^\chi \triangleq \text{play}(\sigma_E, \sigma_A^\chi)$  is won by Eloise, i.e.,  $w^\chi \triangleq \text{obs}(\pi^\chi) \in \text{Wn}$ .

Thanks to all the infinite sequences  $w^\chi$ , one for each assignment  $\chi \in \text{Asg}(\vec{p})$ , we can now define every component  $(\vec{F})_i$  of the vector of functors  $\vec{F} \in (\text{Fnc}(\vec{p}))^{|\vec{q}|}$  as follows, for all instants of time  $t \in \mathbb{N}$ , where  $i \in [0, |\vec{q}|)$ :

$$(\vec{F})_i(\chi)(t) \triangleq (w^\chi)_t((\vec{q})_i).$$

It is not too hard to show that, by construction, this functor complies with the vector  $\vec{\Theta}$  of quantifier specifications.

**Claim 2.**  $\vec{F} \in \text{Fnc}_{\vec{\Theta}}(\vec{p})$ .

At this point, for all assignments  $\chi \in \text{Asg}(\vec{p})$ , let  $\chi_{\vec{F}} \triangleq \text{ext}(\chi, \vec{F}, \vec{q})$ . We can argue that  $\chi_{\vec{F}} \in \Psi$ . Indeed, by construction of the strategy  $\sigma_A^\chi$  and the vector of functors  $\vec{F}$ , it holds that  $\chi_{\vec{F}}(x)(t) = (w^\chi)_t(x)$ , for all instants of time  $t \in \mathbb{N}$  and atomic propositions  $x \in \vec{p} \cdot \vec{q}$ . Hence,  $\text{wrd}(\chi_{\vec{F}}) = w^\chi$ , which implies  $\chi_{\vec{F}} \in \Psi$ , since  $w^\chi \in \text{Wn}$ .

- [2] Since Abelard wins the game, he has a winning strategy, i.e., there is  $\sigma_A \in \text{Str}_A$  such that  $\text{obs}(\text{play}(\sigma_E, \sigma_A)) \notin \text{Wn}$ , for all  $\sigma_E \in \text{Str}_E$ . We want to prove that, for all  $E \in \text{evl}_{\exists\forall}(\text{C}_{\forall\exists}(\varphi))$ , it holds that  $E \not\subseteq \Psi$ .

First, recall that  $\text{C}_{\exists\forall}(\varphi) = \exists^B \vec{q}. \forall^{\vec{\Theta}} \vec{p}$ , for some vectors of atomic propositions  $\vec{p}, \vec{q} \in \text{AP}^*$  and quantifier specifications  $\vec{\Theta} \in \Theta^{|\vec{p}|}$ . Moreover, thanks to Proposition 7, the following claim can be proved by induction on the number of universal variables.

**Claim 3.**  $E \not\subseteq \Psi$ , for all  $E \in \text{evl}_{\exists\forall}(\mathcal{C}_{\exists\forall}(\wp))$ , iff there exists a vector of functors  $\vec{G} \in \text{Fnc}_{\vec{\Theta}}(\vec{q})$  such that  $\text{ext}(\chi, \vec{G}, \vec{p}) \notin \Psi$ , for all assignments  $\chi \in \text{Asg}(\vec{q})$ .

**PROOF.** For technical convenience, we prove the counter-positive version of the statement:  $E \subseteq \Psi$ , for some  $E \in \text{evl}_{\exists\forall}(\mathcal{C}_{\exists\forall}(\wp))$ , iff, for all vectors of functors  $\vec{G} \in \text{Fnc}_{\vec{\Theta}}(\vec{q})$ , it holds that  $\text{ext}(\text{Asg}(\vec{q}), \vec{G}, \vec{p}) \cap \Psi \neq \emptyset$ . As previously observed,  $\mathcal{C}_{\exists\forall}(\wp) = \exists^{\mathbb{B}}\vec{q} \cdot \forall^{\vec{\Theta}}\vec{p}$ , for some vectors  $\vec{p}, \vec{q} \in \text{AP}^*$  and  $\vec{\Theta} \in \Theta^{|\vec{p}|}$ . Thus,  $\text{evl}_{\exists\forall}(\mathcal{C}_{\exists\forall}(\wp)) = \text{evl}_{\exists\forall}(\exists^{\mathbb{B}}\vec{q} \cdot \forall^{\vec{\Theta}}\vec{p}) = \text{evl}_{\exists\forall}(\text{evl}_{\exists\forall}(\exists^{\mathbb{B}}\vec{q}), \forall^{\vec{\Theta}}\vec{p}) = \text{evl}_{\exists\forall}(\{\{\chi\} \mid \chi \in \text{Asg}(\vec{q})\}, \forall^{\vec{\Theta}}\vec{p})$ . At this point, the proof proceeds by induction on the length of the vector  $\vec{p}$ . If  $|\vec{p}| = 0$ , there is nothing really to prove, as the thesis follows immediately from the fact that  $\text{evl}_{\exists\forall}(\mathcal{C}_{\exists\forall}(\wp)) = \{\{\chi\} \mid \chi \in \text{Asg}(\vec{q})\}$ . Let us now consider the case  $|\vec{p}| > 0$  and split both  $\vec{p}$  and  $\vec{\Theta}$  as follows:  $\vec{p} = \vec{p}' \cdot p$  and  $\vec{\Theta} = \vec{\Theta}' \cdot \Theta$ . Obviously,  $\text{evl}_{\exists\forall}(\mathcal{C}_{\exists\forall}(\wp)) = \text{evl}_{\exists\forall}(\text{evl}_{\exists\forall}(\{\{\chi\} \mid \chi \in \text{Asg}(\vec{q})\}, \forall^{\vec{\Theta}'}\vec{p}'), \forall^{\Theta}p)$ . Now, by Item 2 of Proposition 7,  $E \subseteq \Psi$ , for some  $E \in \text{evl}_{\exists\forall}(\mathcal{C}_{\exists\forall}(\wp))$ , iff, for all functors  $G \in \text{Fnc}_{\Theta}(\vec{q} \cdot \vec{p}')$ , there exists a set  $X \in \text{evl}_{\exists\forall}(\{\{\chi\} \mid \chi \in \text{Asg}(\vec{q})\}, \forall^{\vec{\Theta}'}\vec{p}')$  such that  $\text{ext}(X, G, p) \subseteq \Psi$ . The latter inclusion can be rewritten as  $X \subseteq \text{prj}(\Psi, G, p)$ , where  $\text{prj}(\Psi, G, p) \triangleq \{\chi \in \text{Asg}(\vec{q} \cdot \vec{p}') \mid \text{ext}(\chi, G, p) \in \Psi\}$ . At this point, by the inductive hypothesis applied to the inclusion  $X \subseteq \text{prj}(\Psi, G, p)$ , for some  $X \in \text{evl}_{\exists\forall}(\{\{\chi\} \mid \chi \in \text{Asg}(\vec{q})\}, \forall^{\vec{\Theta}'}\vec{p}')$ , we obtain that  $E \subseteq \Psi$ , for some  $E \in \text{evl}_{\exists\forall}(\mathcal{C}_{\exists\forall}(\wp))$ , iff for all functors  $G \in \text{Fnc}_{\Theta}(\vec{q} \cdot \vec{p}')$  and vectors of functors  $\vec{G}' \in \text{Fnc}_{\vec{\Theta}'}$ , it holds that  $\text{ext}(\text{Asg}(\vec{q}), \vec{G}', \vec{p}') \cap \text{prj}(\Psi, G, p) \neq \emptyset$ . The latter inequality can now be rewritten as  $\text{ext}(\text{ext}(\text{Asg}(\vec{q}), \vec{G}', \vec{p}'), G, p) \cap \Psi \neq \emptyset$ . To conclude the proof, it is enough to observe that the vectors of functors  $\vec{G} \in \text{Fnc}_{\vec{\Theta}}(\vec{q})$  can always be obtained by juxtaposing the vectors  $\vec{G}'$  with the functors  $G^* \in \text{Fnc}_{\Theta}(\vec{q})$  obtained by composing  $G$  with  $\vec{G}'$  as follows:  $G^*(\chi) \triangleq G(\text{ext}(\chi, \vec{G}', \vec{p}'))$ .  $\square$

Due to the above characterisation of non-existence of a set  $E \in \text{evl}_{\exists\forall}(\mathcal{C}_{\exists\forall}(\wp))$  such that  $E \subseteq \Psi$ , the thesis can be proved by defining a suitable vector of functors  $\vec{G} \in \text{Fnc}_{\vec{\Theta}}(\vec{q})$ . Consider an arbitrary assignment  $\chi \in \text{Asg}(\vec{q})$  and define the function  $\widehat{\sigma}_E^\chi: \text{Ob}^* \cdot \text{Ps}_E \rightarrow \text{Ps}$  as follows, for all finite sequences of observable positions  $w \in \text{Ob}^*$  and Eloise's positions  $\xi \in \text{Ps}_E$ :

$$\widehat{\sigma}_E^\chi(w \cdot \xi) \triangleq \xi[x \mapsto \chi(x)(|w|)],$$

where  $x \in \vec{q}$  is the atomic proposition at position  $\#(\xi)$  in the prefix  $\wp$ , i.e.,  $(\wp)_{\#(\xi)} = \exists^{\mathbb{B}}x$ . Due to the bijective correspondence previously described, there is a unique strategy  $\sigma_E^\chi \in \text{Str}_E$  such that  $\sigma_E^\chi(\rho) = \widehat{\sigma}_E^\chi(j_E(\rho))$ , for all histories  $\rho \in \text{Hst}_E$ . Obviously, the induced play  $\pi^\chi \triangleq \text{play}(\sigma_E^\chi, \sigma_A)$  is won by Abelard, i.e.,  $w^\chi \triangleq \text{obs}(\pi^\chi) \notin \text{Wn}$ .

Thanks to all the infinite sequences  $w^\chi$ , one for each assignment  $\chi \in \text{Asg}(\vec{q})$ , we can now define every component  $(\vec{G})_i$  of the vector of functors  $\vec{G} \in (\text{Fnc}(\vec{q}))^{|\vec{p}|}$  as follows, for all instants of time  $t \in \mathbb{N}$ , where  $i \in [0, |\vec{p}|)$ :

$$(\vec{G})_i(\chi)(t) \triangleq (w^\chi)_t((\vec{p})_i).$$

It is not too hard to show that, by construction, this functor complies with the vector  $\vec{\Theta}$  of quantifier specifications.

**Claim 4.**  $\vec{G} \in \text{Fnc}_{\vec{\Theta}}(\vec{q})$ .

At this point, for all assignments  $\chi \in \text{Asg}(\vec{q})$ , let  $\chi_{\vec{G}} \triangleq \text{ext}(\chi, \vec{G}, \vec{p})$ . We can argue that  $\chi_{\vec{G}} \notin \Psi$ . Indeed, by construction of the strategy  $\sigma_{\vec{E}}^\chi$  and the vector of functors  $\vec{G}$ , it holds that  $\chi_{\vec{G}}(x)(t) = (w^\chi)_t(x)$ , for all instants of time  $t \in \mathbb{N}$  and atomic propositions  $x \in \vec{q} \cdot \vec{p}$ . Hence,  $\text{wr}d(\chi_{\vec{G}}) = w^\chi$ , which implies  $\chi_{\vec{G}} \notin \Psi$ , since  $w^\chi \notin \text{Wn}$ .  $\square$

The two conditions stated in Proposition 7 allow us to introduce a different, but equivalent (in terms of the equivalence relation  $\equiv$  between hyperassignments), definition of evolution function that we call *normal*, in symbols  $\text{nevl}$ . This new notion will be useful to show important properties that would be, otherwise, much more cumbersome to prove by appealing directly to the original definition of the evolution function  $\text{evl}$ .

$$\text{nevl}_\alpha(\mathfrak{X}, Q^\ominus p) \triangleq \begin{cases} \text{ext}_\Theta(\mathfrak{X}, p), & \text{if } Q \text{ is } \alpha\text{-coherent;} \\ \{\text{ext}(\vec{\delta}, p) \mid \vec{\delta} \in \text{Fnc}_\Theta(\text{ap}(\mathfrak{X})) \rightarrow \mathfrak{X}\}, & \text{otherwise;} \end{cases}$$

where  $\text{ext}(\vec{\delta}, p) \triangleq \bigcup \{\text{ext}(\vec{\delta}(F), F, p) \mid F \in \text{dom}(\vec{\delta})\}$ . Intuitively, *w.r.t.*  $\text{evl}$ , we just modified the non  $\alpha$ -coherent case, in order to avoid the double application of the dualization function, by replacing this with a choice of a selection map  $\vec{\delta} \in \text{Fnc}_\Theta(\text{ap}(\mathfrak{X})) \rightarrow \mathfrak{X}$  selecting, in fact, for each  $\Theta$ -functor  $F \in \text{Fnc}_\Theta(\text{ap}(\mathfrak{X}))$ , a set of assignments  $\vec{\delta}(F) \in \mathfrak{X}$ .

The new evolution operator lifts naturally to an arbitrary quantification prefix  $\wp \in \text{Qn}$  as follows: (1)  $\text{nevl}_\alpha(\mathfrak{X}, \epsilon) \triangleq \mathfrak{X}$ ; (2)  $\text{nevl}_\alpha(\mathfrak{X}, Q^\ominus p, \wp) \triangleq \text{nevl}_\alpha(\text{nevl}_\alpha(\mathfrak{X}, Q^\ominus p), \wp)$ . As we have done for  $\text{evl}$ , we also set  $\text{nevl}_\alpha(\wp) \triangleq \text{nevl}_\alpha(\{\{\emptyset\}, \wp\})$ .

**Example 12.** Consider the quantifier  $\exists q$  and the hyperassignment  $\mathfrak{X} = \{X_1, X_2\}$  with  $X_i = \{\chi_i\}$ , where  $i \in \{1, 2\}$  and  $\chi_1 \triangleq \{p \mapsto \top^\omega\}$  and  $\chi_2 \triangleq \{p \mapsto \perp^\omega\}$ . Since  $\exists q$  is  $\exists\forall$ -coherent, we have

$$\text{nevl}_{\exists\forall}(\mathfrak{X}, \exists q) = \text{ext}(\mathfrak{X}, q).$$

On the other hand,  $\exists q$  is not  $\forall\exists$ -coherent, thus

$$\text{nevl}_{\forall\exists}(\mathfrak{X}, \exists q) = \{\text{ext}(\vec{\delta}, q) \mid \vec{\delta} \in \text{Fnc}(\text{ap}(\mathfrak{X})) \rightarrow \mathfrak{X}\}.$$

For instance, consider  $\vec{\delta}_0 : \text{Fnc}_\Theta(\text{ap}(\mathfrak{X})) \rightarrow \mathfrak{X}$  defined as follows:

$$\vec{\delta}_0(F) \triangleq \begin{cases} X_1, & \text{if } F(\chi_1)(0) = \top \\ X_2, & \text{otherwise.} \end{cases}$$

Intuitively, the selection function  $\vec{\delta}_0$  bipartitions the functors according to the value that they assign to  $\chi_1$  at time 0, by associating each functor with one of the two sets of assignments,  $X_1$  or  $X_2$ . We thus have

$$\begin{aligned} \text{ext}(\vec{\delta}_0, q) &= \bigcup \{\text{ext}(\vec{\delta}_0(F), F, q) \mid F \in \text{Fnc}_\Theta(\text{ap}(\mathfrak{X}))\} \\ &= \bigcup \{\text{ext}(X_1, F, q) \mid F \in \text{Fnc}_\Theta(\text{ap}(\mathfrak{X})), F(\chi_1)(0) = \top\} \cup \\ &\quad \bigcup \{\text{ext}(X_2, F, q) \mid F \in \text{Fnc}_\Theta(\text{ap}(\mathfrak{X})), F(\chi_1)(0) = \perp\}. \end{aligned}$$

**Proposition 8.** If  $\mathfrak{X}_1 \equiv \mathfrak{X}_2$  then  $\text{nevl}_\alpha(\mathfrak{X}_1, Q^\ominus p) \equiv \text{evl}_\alpha(\mathfrak{X}_2, Q^\ominus p)$ , for all hyperassignments  $\mathfrak{X}_1, \mathfrak{X}_2 \in \text{HAsg}$ , quantifier symbols  $Q \in \{\exists, \forall\}$ , quantifier specifications  $\Theta \in \Theta$ , and atomic propositions  $p \in \text{AP} \setminus \text{ap}(\mathfrak{X})$ .

**PROOF.** The proof proceeds by a case analysis on the coherence of  $\alpha$  and  $Q$ .

- [**Q is  $\alpha$ -coherent**] By definition,  $\text{nevl}_\alpha(\mathfrak{X}_1, Q^\ominus p) = \text{ext}_\Theta(\mathfrak{X}_1, p)$  and  $\text{evl}_\alpha(\mathfrak{X}_2, Q^\ominus p) = \text{ext}_\Theta(\mathfrak{X}_2, p)$ . Since  $\mathfrak{X}_1 \equiv \mathfrak{X}_2$ , by Proposition 4, it holds that  $\text{ext}_\Theta(\mathfrak{X}_1, p) \equiv \text{ext}_\Theta(\mathfrak{X}_2, p)$ , which conclude this case of the proof.

- **[Q is not  $\alpha$ -coherent]** By definition,  $\text{nevl}_\alpha(\mathfrak{X}_1, Q^\ominus p) = \{\text{ext}(\bar{\delta}, p) \mid \bar{\delta} \in \text{Fnc}_\ominus(\text{ap}(\mathfrak{X}_1)) \rightarrow \mathfrak{X}_1\}$  and  $\text{evl}_\alpha(\mathfrak{X}_2, Q^\ominus p) = \text{ext}_\ominus(\overline{\mathfrak{X}_2}, p)$ . We now prove the two inclusions  $\text{nevl}_\alpha(\mathfrak{X}_1, Q^\ominus p) \sqsubseteq \text{evl}_\alpha(\mathfrak{X}_2, Q^\ominus p)$  and  $\text{nevl}_\alpha(\mathfrak{X}_1, Q^\ominus p) \supseteq \text{evl}_\alpha(\mathfrak{X}_2, Q^\ominus p)$  separately.
    - $[\sqsubseteq]$  To prove  $\text{nevl}_\alpha(\mathfrak{X}_1, Q^\ominus p) \sqsubseteq \text{evl}_\alpha(\mathfrak{X}_2, Q^\ominus p)$ , we need to show that, for any  $\Psi \in \text{nevl}_\alpha(\mathfrak{X}_1, Q^\ominus p)$  there is  $W_\Psi \in \text{evl}_\alpha(\mathfrak{X}_2, Q^\ominus p)$  such that  $W_\Psi \subseteq \Psi$ . Obviously, for any  $\Psi \in \text{nevl}_\alpha(\mathfrak{X}_1, Q^\ominus p)$ , it holds that  $\Psi = \text{ext}(\bar{\delta}, p) = \bigcup \{\text{ext}(\bar{\delta}(F), F, p) \mid F \in \text{dom}(\bar{\delta})\}$ , for some selection function  $\bar{\delta} \in \text{Fnc}_\ominus(\text{ap}(\mathfrak{X}_1)) \rightarrow \mathfrak{X}_1$ . This means that, for every  $F \in \text{Fnc}_\ominus(\text{ap}(\mathfrak{X}_1))$ , there is  $X_F \triangleq \bar{\delta}(F) \in \mathfrak{X}_1$  such that  $\text{ext}(X_F, F, p) \subseteq \Psi$ . Now, by Item 2 of Proposition 7, there exists  $W_1 \in \text{evl}_\alpha(\mathfrak{X}_1, Q^\ominus p)$  such that  $W_1 \subseteq \Psi$ . Since, thanks to Proposition 5,  $\mathfrak{X}_1 \equiv \mathfrak{X}_2$  implies  $\text{evl}_\alpha(\mathfrak{X}_1, Q^\ominus p) \equiv \text{evl}_\alpha(\mathfrak{X}_2, Q^\ominus p)$ , we have that there is  $W_2 \in \text{evl}_\alpha(\mathfrak{X}_2, Q^\ominus p)$  such that  $W_2 \subseteq W_1 \subseteq \Psi$ . Finally, by setting  $W_\Psi \triangleq W_2$ , we obtain what is required.
    - $[\supseteq]$  To prove  $\text{nevl}_\alpha(\mathfrak{X}_1, Q^\ominus p) \supseteq \text{evl}_\alpha(\mathfrak{X}_2, Q^\ominus p)$ , we need to show that, for any  $\Psi \in \text{evl}_\alpha(\mathfrak{X}_2, Q^\ominus p)$  there is  $W_\Psi \in \text{nevl}_\alpha(\mathfrak{X}_1, Q^\ominus p)$  such that  $W_\Psi \subseteq \Psi$ . By instantiating  $W$  with  $\Psi$  in Proposition 7, since  $W = \Psi \in \text{evl}_\alpha(\mathfrak{X}_2, Q^\ominus p)$ , from Item 2 we derive that, for all  $F \in \text{Fnc}_\ominus(\text{ap}(\mathfrak{X}_2))$ , there is  $X_{F_2} \in \mathfrak{X}_2$  such that  $\text{ext}(X_{F_2}, F, p) \subseteq \Psi$ . Now, since  $\mathfrak{X}_1 \equiv \mathfrak{X}_2$ , there is  $X_{F_1} \in \mathfrak{X}_1$  such that  $X_{F_1} \subseteq X_{F_2}$ , which in turn implies  $\text{ext}(X_{F_1}, F, p) \subseteq \text{ext}(X_{F_2}, F, p) \subseteq \Psi$ . At this point, define the selection map  $\bar{\delta} \in \text{Fnc}_\ominus(\text{ap}(\mathfrak{X}_1)) \rightarrow \mathfrak{X}_1$  as follows:  $\bar{\delta}(F) \triangleq X_{F_1}$ , for every  $F \in \text{Fnc}_\ominus(\text{ap}(\mathfrak{X}_1)) = \text{Fnc}_\ominus(\text{ap}(\mathfrak{X}_2))$ . Clearly, by setting  $W_\Psi \triangleq \text{ext}(\bar{\delta}, p)$ , both  $W_\Psi = \bigcup \{\text{ext}(\bar{\delta}(F), F, p) \mid F \in \text{dom}(\bar{\delta})\} \subseteq \Psi$  and  $W_\Psi \in \text{nevl}_\alpha(\mathfrak{X}_1, Q^\ominus p)$  holds true, as required.
- This concludes the proof of the second and last case.  $\square$

The following examples is meant to show how the normal  $\alpha$ -evolution function for non-coherent quantifier simulates the  $\alpha$ -evolution function for the same quantifier.

**Example 13.** The function  $\bar{\delta}_0$  of Example 12 can be viewed as a choice function on  $\text{ext}(\overline{\mathfrak{X}}, q)$ . First, recall that  $\overline{\mathfrak{X}} = \{X_{12}\}$  with  $X_{12} = \{\chi_1, \chi_2\}$  and let  $\dot{X} \in \text{ext}(\overline{\mathfrak{X}}, q)$ . Then, there is  $F \in \text{Fnc}(\text{ap}(\mathfrak{X}))$  such that  $\dot{X} = \text{ext}(X_{12}, F, q)$ . If we define a choice function  $\Gamma \in \text{Chc}(\text{ext}(\overline{\mathfrak{X}}, q))$  so that

$$\Gamma(\dot{X}) = \Gamma(\text{ext}(X_{12}, F, q)) = \begin{cases} \chi_1[q \mapsto F(\chi_1)], & \text{if } F(\chi_1)(0) = \top, \\ \chi_2[q \mapsto F(\chi_2)], & \text{otherwise,} \end{cases}$$

it is straightforward to see that  $\text{ext}(\bar{\delta}_0, q) = \text{img}(\Gamma) \in \text{evl}_{\forall\exists}(\mathfrak{X}, \exists q)$ .

**Proposition 9.** If  $\mathfrak{X}_1 \equiv \mathfrak{X}_2$  then  $\text{nevl}_\alpha(\mathfrak{X}_1, \wp) \equiv \text{evl}_\alpha(\mathfrak{X}_2, \wp)$ , for all hyperassignments  $\mathfrak{X}_1, \mathfrak{X}_2 \in \text{HAsg}$  and quantifier prefixes  $\wp \in \text{Qn}$ , with  $\text{ap}(\mathfrak{X}) \cap \text{ap}(\wp) = \emptyset$ .

**PROOF.** The proof proceeds by simple induction on the length of the quantification prefix  $\wp$ .

- **[Base case  $\wp = \varepsilon$ ]**  $\text{nevl}_\alpha(\mathfrak{X}_1, \varepsilon) = \mathfrak{X}_1 \equiv \mathfrak{X}_2 = \text{evl}_\alpha(\mathfrak{X}_2, \varepsilon)$ .
- **[Inductive case  $\wp = Q^\ominus p. \wp'$ ]** By definition, we have  $\text{nevl}_\alpha(\mathfrak{X}_1, Q^\ominus p. \wp') = \text{nevl}_\alpha(\text{nevl}_\alpha(\mathfrak{X}_1, Q^\ominus p), \wp')$  and  $\text{evl}_\alpha(\mathfrak{X}_2, Q^\ominus p. \wp') = \text{evl}_\alpha(\text{evl}_\alpha(\mathfrak{X}_2, Q^\ominus p), \wp')$ . Now, by Proposition 8,  $\text{nevl}_\alpha(\mathfrak{X}_1, Q^\ominus p) \equiv \text{evl}_\alpha(\mathfrak{X}_2, Q^\ominus p)$ , since  $\mathfrak{X}_1 \equiv \mathfrak{X}_2$ . Thus, the thesis follows by a straightforward application of the inductive hypothesis.  $\square$

In the following, by  $\ominus_B$  we denote the set of behavioural quantifier specifications, i.e., quantifier specifications of the form  $B \cup \langle S : P_S \rangle$  for some set of atomic propositions  $P_S \subseteq \text{AP}$ .

**Proposition 10.**  $\text{evl}_\alpha(\mathfrak{X}, \overline{Q}^B p. Q^{\ominus \cup \langle S : P \rangle} q) \sqsubseteq \text{evl}_\alpha(\mathfrak{X}, Q^\ominus q. \overline{Q}^B p)$ , for all hyperassignments  $\mathfrak{X} \in \text{HAsg}$ ,  $\alpha$ -coherent quantifier symbols  $Q \in \{\exists, \forall\}$ , quantifier specifications  $\Theta \in \ominus_B$ , and atomic propositions  $p, q \in \text{AP} \setminus \text{ap}(\mathfrak{X})$ .

PROOF. Due to the specific definition of the normal evolution function  $\text{nevl}_\alpha(\mathfrak{X}, \wp)$ , and by exploiting Proposition 9, the following claim can be shown.

**Claim 5.** *The following two properties are equivalent:*

- $\text{evl}_\alpha(\mathfrak{X}, \bar{Q}^B p. Q^{\Theta \cup \langle S : p \rangle} q) \sqsubseteq \text{evl}_\alpha(\mathfrak{X}, Q^\Theta q. \bar{Q}^B p)$ ;
- for all  $(\Theta \cup \langle S : p \rangle)$ -functors  $J \in \text{Fnc}_{\Theta \cup \langle S : p \rangle}(\text{ap}(\mathfrak{X}) \cup \{p\})$ , functions  $\bar{\delta} \in \text{Fnc}_B(\text{ap}(\mathfrak{X})) \rightarrow \mathfrak{X}$ , and behavioural functors  $G \in \text{Fnc}_B(\text{ap}(\mathfrak{X}) \cup \{q\})$ , there exists a  $\Theta$ -functor  $F \in \text{Fnc}_\Theta(\text{ap}(\mathfrak{X}))$  and a set of assignments  $X \in \mathfrak{X}$  such that  $\text{ext}(\text{ext}(X, F, q), G, p) \subseteq \text{ext}(\text{ext}(\bar{\delta}, p), J, q)$ .

PROOF. By Proposition 9, the inclusion  $\text{evl}_\alpha(\mathfrak{X}, \bar{Q}^B p. Q^{\Theta \cup \langle S : p \rangle} q) \sqsubseteq \text{evl}_\alpha(\mathfrak{X}, Q^\Theta q. \bar{Q}^B p)$  is equivalent to the inclusion  $\text{nevl}_\alpha(\mathfrak{X}, \bar{Q}^B p. Q^{\Theta \cup \langle S : p \rangle} q) \sqsubseteq \text{nevl}_\alpha(\mathfrak{X}, Q^\Theta q. \bar{Q}^B p)$ , which in turn means that, for all sets  $W_1 \in \text{nevl}_\alpha(\mathfrak{X}, \bar{Q}^B p. Q^{\Theta \cup \langle S : p \rangle} q)$ , there exists a set  $W_2 \in \text{nevl}_\alpha(\mathfrak{X}, Q^\Theta q. \bar{Q}^B p)$  such that  $W_2 \subseteq W_1$ . Now, by definition of normal evolution function, we have that

$$\text{nevl}_\alpha(\mathfrak{X}, \bar{Q}^B p. Q^{\Theta \cup \langle S : p \rangle} q) = \text{ext}_{\Theta \cup \langle S : p \rangle}(\{\text{ext}(\bar{\delta}, p) \mid \bar{\delta} \in \text{Fnc}_B(\text{ap}(\mathfrak{X})) \rightarrow \mathfrak{X}\}, q)$$

and

$$\text{nevl}_\alpha(\mathfrak{X}, Q^\Theta q. \bar{Q}^B p) = \{\text{ext}(\bar{\delta}, p) \mid \bar{\delta} \in \text{Fnc}_B(\text{ap}(\mathfrak{X}) \cup \{q\}) \rightarrow \text{ext}_\Theta(\mathfrak{X}, q)\}.$$

Thus, every set  $W_1$  is equal to  $\text{ext}(\text{ext}(\bar{\delta}, p), J, q)$ , for some  $(\Theta \cup \langle S : p \rangle)$ -functor  $J \in \text{Fnc}_{\Theta \cup \langle S : p \rangle}(\text{ap}(\mathfrak{X}) \cup \{p\})$  and selection function  $\bar{\delta} \in \text{Fnc}_B(\text{ap}(\mathfrak{X})) \rightarrow \mathfrak{X}$ , while every set  $W_2$  is equal to  $\text{ext}(\bar{\delta}', p)$ , for some selection function  $\bar{\delta}' \in \text{Fnc}_B(\text{ap}(\mathfrak{X}) \cup \{q\}) \rightarrow \text{ext}_\Theta(\mathfrak{X}, q)$ . As a consequence, the previous property concerning the inclusion  $W_2 \subseteq W_1$  can be equivalently rewritten as follows: for all  $(\Theta \cup \langle S : p \rangle)$ -functors  $J \in \text{Fnc}_{\Theta \cup \langle S : p \rangle}(\text{ap}(\mathfrak{X}) \cup \{p\})$  and selection functions  $\bar{\delta} \in \text{Fnc}_B(\text{ap}(\mathfrak{X})) \rightarrow \mathfrak{X}$ , there exists a selection function  $\bar{\delta}' \in \text{Fnc}_B(\text{ap}(\mathfrak{X}) \cup \{q\}) \rightarrow \text{ext}_\Theta(\mathfrak{X}, q)$  such that  $\text{ext}(\bar{\delta}', p) \subseteq \text{ext}(\text{ext}(\bar{\delta}, p), J, q)$ . Since,  $\text{ext}(\bar{\delta}', p) = \bigcup \{\text{ext}(\bar{\delta}'(G), G, p) \mid G \in \text{Fnc}_B(\text{ap}(\mathfrak{X}) \cup \{q\})\}$ , the inclusion  $\text{ext}(\bar{\delta}', p) \subseteq \text{ext}(\text{ext}(\bar{\delta}, p), J, q)$  is equivalent to  $\text{ext}(\bar{\delta}'(G), G, p) \subseteq \text{ext}(\text{ext}(\bar{\delta}, p), J, q)$ , for all behavioural functors  $G \in \text{Fnc}_B(\text{ap}(\mathfrak{X}) \cup \{q\})$ . Hence, up to this point, we have proved that the following two properties are equivalent:

- $\text{evl}_\alpha(\mathfrak{X}, \bar{Q}^B p. Q^{\Theta \cup \langle S : p \rangle} q) \sqsubseteq \text{evl}_\alpha(\mathfrak{X}, Q^\Theta q. \bar{Q}^B p)$ ;
- for all  $(\Theta \cup \langle S : p \rangle)$ -functors  $J \in \text{Fnc}_{\Theta \cup \langle S : p \rangle}(\text{ap}(\mathfrak{X}) \cup \{p\})$  and functions  $\bar{\delta} \in \text{Fnc}_B(\text{ap}(\mathfrak{X})) \rightarrow \mathfrak{X}$ , there exists a function  $\bar{\delta}' \in \text{Fnc}_B(\text{ap}(\mathfrak{X}) \cup \{q\}) \rightarrow \text{ext}_\Theta(\mathfrak{X}, q)$  such that, for all behavioural functors  $G \in \text{Fnc}_B(\text{ap}(\mathfrak{X}) \cup \{q\})$ , it holds that  $\text{ext}(\bar{\delta}'(G), G, p) \subseteq \text{ext}(\text{ext}(\bar{\delta}, p), J, q)$ .

Now, by deSkolemizing the existential quantification of  $\bar{\delta}'$  w.r.t. the universal quantification of  $G$ , the second point is equivalent to the following: for all  $(\Theta \cup \langle S : p \rangle)$ -functors  $J \in \text{Fnc}_{\Theta \cup \langle S : p \rangle}(\text{ap}(\mathfrak{X}) \cup \{p\})$ , functions  $\bar{\delta} \in \text{Fnc}_B(\text{ap}(\mathfrak{X})) \rightarrow \mathfrak{X}$ , and behavioural functors  $G \in \text{Fnc}_B(\text{ap}(\mathfrak{X}) \cup \{q\})$ , there exists a set  $Y \in \text{ext}_\Theta(\mathfrak{X}, q)$  such that  $\text{ext}(Y, G, p) \subseteq \text{ext}(\text{ext}(\bar{\delta}, p), J, q)$ . Finally, to obtain what is required by the statement of the claim, it is enough to observe that every set  $Y$  is equal to  $\text{ext}(X, F, q)$ , for some  $\Theta$ -functor  $F \in \text{Fnc}_\Theta(\text{ap}(\mathfrak{X}))$  and set  $X \in \mathfrak{X}$ .  $\square$

Thanks to the given characterisation, we can now show that the inclusion  $\text{evl}_\alpha(\mathfrak{X}, \bar{Q}^B p. Q^{\Theta \cup \langle S : p \rangle} q) \sqsubseteq \text{evl}_\alpha(\mathfrak{X}, Q^\Theta q. \bar{Q}^B p)$  actually holds true by proving the existence of a suitable functor  $F$  and set of assignments  $X$ , in dependence of the functors  $J$  and  $G$  and the selection map  $\bar{\delta}$ , that satisfy the inclusion  $\text{ext}(\text{ext}(X, F, q), G, p) \subseteq \text{ext}(\text{ext}(\bar{\delta}, p), J, q)$ . In order to define such a functor  $F$ , let us inductively construct, for every given assignment  $\chi \in \text{Asg}(\text{ap}(\mathfrak{X}))$ , the following infinite families of assignments  $\{a_t^\chi \in \text{Asg}(\text{ap}(\mathfrak{X}) \cup \{p\})\}_{t \in \mathbb{N}}$ , Boolean values  $\{v_t^\chi \in \mathbb{B}\}_{t \in \mathbb{N}}$ , and assignments  $\{b_t^\chi \in \text{Asg}(\text{ap}(\mathfrak{X}) \cup \{q\})\}_{t \in \mathbb{N}}$ , indexed by the time instants:

- **[Base step  $t = 0$ ]** as base step, we choose  $a_0^\chi \in \text{Asg}(\text{ap}(\mathfrak{X}) \cup \{p\})$  as an arbitrary assignment for which the equality  $a_0^\chi \upharpoonright \text{ap}(\mathfrak{X}) = \chi$  holds true, the Boolean value  $v_0^\chi \in \mathbb{B}$  as  $J(a_0^\chi)(0)$ , i.e.,

$v_0^X \triangleq J(a_0^X)(0)$ , and  $b_0^X \in \text{Asg}(\text{ap}(\mathfrak{X}) \cup \{q\})$  as an arbitrary assignment with  $b_0^X \upharpoonright \text{ap}(\mathfrak{X}) = \chi$  such that, at time 0 on the variable  $q$ , assumes  $v_0^X$  as value, i.e.,  $b_0^X(q)(0) = v_0^X$ ;

- **[Inductive step  $t > 0$ ]** as inductive step, we derive the assignment  $a_t^X \in \text{Asg}(\text{ap}(\mathfrak{X}) \cup \{p\})$  from  $G(b_{t-1}^X)$ , i.e.,  $a_t^X \triangleq \chi[p \mapsto G(b_{t-1}^X)]$ , and the Boolean value  $v_t^X \in \mathbb{B}$  from  $J(a_t^X)(t)$ , i.e.,  $v_t^X \triangleq J(a_t^X)(t)$ ; moreover, we choose  $b_t^X \in \text{Asg}(\text{ap}(\mathfrak{X}) \cup \{q\})$  as an arbitrary assignment with  $b_t^X \upharpoonright \text{ap}(\mathfrak{X}) = \chi$  such that, on the variable  $q$ , is equal to  $b_{t-1}^X$  up to time  $t$  excluded and assumes  $v_t^X$  as value at time  $t$ , i.e.,  $b_t^X(q)(h) = b_{t-1}^X(q)(h)$ , for all  $h \in [0, t)$ , and  $b_t^X(q)(t) = v_t^X$ .

The above inductive construction can be schematically summarised as follows, where, for every  $t \in \mathbb{N}$ , both  $g_t$  and  $j_t$  are temporal assignments, i.e., functions of the form  $g_t, j_t \in \mathbb{N} \rightarrow \mathbb{B}$ :

$$\frac{a_0^X \triangleq \chi[p \mapsto g_0], \text{ for some } g_0; \quad v_0^X \triangleq J(a_0^X)(0); \quad b_0^X \triangleq \chi[q \mapsto j_0], \text{ for some } j_0 \text{ with } j_0(0) = v_0^X;}{a_t^X \triangleq \chi[p \mapsto G(b_{t-1}^X)]; \quad v_t^X \triangleq J(a_t^X)(t); \quad b_t^X \triangleq \chi[q \mapsto j_t], \text{ for some } j_t \text{ such that, for all } h \in [0, t], \quad j_t(h) = \begin{cases} j_{t-1}(h), & \text{if } h < t; \\ v_t^X, & \text{if } h = t. \end{cases}}$$

Thanks to the infinite family of Boolean values  $\{v_t^X \in \mathbb{B}\}_{t \in \mathbb{N}}$ , one for each assignment  $\chi \in \text{Asg}(\text{ap}(\mathfrak{X}))$ , we can define the functor  $F \in \text{Fnc}(\text{ap}(\mathfrak{X}))$  as follows, for every instant of time  $t \in \mathbb{N}$ :

$$F(\chi)(t) \triangleq v_t^X.$$

It is easy to show that this functor complies with the quantifier specification  $\Theta$ , since the functor  $J$ , from which  $F$  is derived, is compliant with the quantifier specification  $\Theta \cup \{S : p\}$ .

**Claim 6.**  $F \in \text{Fnc}_\Theta(\text{ap}(\mathfrak{X}))$ .

Before continuing, let us first introduce the functor  $H \in \text{Fnc}(\text{ap}(\mathfrak{X}))$  as follows, for every assignment  $\chi \in \text{Asg}(\text{ap}(\mathfrak{X}))$ :

$$H(\chi) \triangleq \text{ext}(\text{ext}(\chi, F, q), G, p)(p).$$

It is not hard to verify that such a functor is behavioural, since  $F$  is  $\Theta$ -compliant and  $G$  is behavioural.

**Claim 7.**  $H \in \text{Fnc}_\mathbb{B}(\text{ap}(\mathfrak{X}))$ .

At this point, consider the set of assignments  $X \triangleq \bar{\delta}(H)$ . Thanks to the specific definitions of the two functors  $F$  and  $H$ , the following claim can be proved.

**Claim 8.**  $\text{ext}(\text{ext}(X, F, q), G, p) \subseteq \text{ext}(\text{ext}(X, H, p), J, q)$ .

Now, it is obvious that  $\text{ext}(X, H, p) \subseteq \text{ext}(\bar{\delta}, p)$ , due to the definition of the latter and the choice of the set  $X$ , which immediately implies  $\text{ext}(\text{ext}(X, H, p), J, q) \subseteq \text{ext}(\text{ext}(\bar{\delta}, p), J, q)$ . Therefore,  $\text{ext}(\text{ext}(X, F, q), G, p) \subseteq \text{ext}(\text{ext}(\bar{\delta}, p), J, q)$ , which concludes the proof.  $\square$

**Proposition 11.**  $\text{evl}_\alpha(\mathfrak{X}, \bar{Q} \bar{p}. \bar{Q}^{\bar{\Theta} \cup \langle S; \bar{p} \rangle} \bar{q}) \sqsubseteq \text{evl}_\alpha(\mathfrak{X}, \bar{Q}^{\bar{\Theta}} \bar{q}. \bar{Q}^{\bar{B}} \bar{p})$ , for all hyperassignments  $\mathfrak{X} \in \text{HAsg}$ ,  $\alpha$ -coherent quantifier symbols  $Q \in \{\exists, \forall\}$ , vectors of quantifier specifications  $\bar{\Theta} \in \Theta_{\mathbb{B}}^*$ , and vectors of atomic propositions  $\bar{p}, \bar{q} \in (\text{AP} \setminus \text{ap}(\mathfrak{X}))^*$ , with  $|\bar{q}| = |\bar{\Theta}|$ .

**PROOF.** The proof of the statements proceeds by combining two independent inductions. In particular, we first show, by exploiting Proposition 10 via an induction on the length of the vector

of atomic propositions  $\vec{p}$ , that  $\text{evl}_\alpha(\mathfrak{X}, \vec{Q}^{\vec{B}} \vec{p}. Q^{\Theta \cup \langle S; \vec{p} \rangle} q) \sqsubseteq \text{evl}_\alpha(\mathfrak{X}, Q^\Theta q. \vec{Q}^{\vec{B}} \vec{p})$ . Indeed, one can easily verify the correctness of the following chain of equalities/inequalities:

$$\text{evl}_\alpha(\mathfrak{X}, \vec{Q}^{\vec{B}} \vec{p}. \vec{Q}^{\vec{B}} p. Q^{\Theta \cup \langle S; \vec{p} p \rangle} q) = \text{evl}_\alpha(\text{evl}_\alpha(\mathfrak{X}, \vec{Q}^{\vec{B}} \vec{p}), \vec{Q}^{\vec{B}} p. Q^{(\Theta \cup \langle S; \vec{p} \rangle) \cup \langle S; p \rangle} q) \quad (1a)$$

$$\sqsubseteq \text{evl}_\alpha(\text{evl}_\alpha(\mathfrak{X}, \vec{Q}^{\vec{B}} \vec{p}), Q^{\Theta \cup \langle S; \vec{p} \rangle} q. \vec{Q}^{\vec{B}} p) \quad (1b)$$

$$= \text{evl}_\alpha(\text{evl}_\alpha(\mathfrak{X}, \vec{Q}^{\vec{B}} \vec{p}. Q^{\Theta \cup \langle S; \vec{p} \rangle} q), \vec{Q}^{\vec{B}} p) \quad (1c)$$

$$\sqsubseteq \text{evl}_\alpha(\text{evl}_\alpha(\mathfrak{X}, Q^\Theta q. \vec{Q}^{\vec{B}} \vec{p}), \vec{Q}^{\vec{B}} p) \quad (1d)$$

$$= \text{evl}_\alpha(\mathfrak{X}, Q^\Theta q. \vec{Q}^{\vec{B}} \vec{p}. \vec{Q}^{\vec{B}} p). \quad (1e)$$

Steps 1a, 1c, and 1e are due to the definition of evolution function of a quantifier prefix, Step 1b is due to Proposition 10 applied to the outer evolution function, and, finally, Step 1d is just an application of the inductive hypothesis to the inner evolution function combined with the monotonicity property of Proposition 5.

At this point, by exploiting what we have just derived via an induction on the length of the vector of atomic propositions  $\vec{q}$ , we can prove the correctness of the statement by means of the following chain of equalities/inequalities:

$$\text{evl}_\alpha(\mathfrak{X}, \vec{Q}^{\vec{B}} \vec{p}. Q^{\Theta \cup \langle S; \vec{p} \rangle} \vec{q}. Q^{\Theta \cup \langle S; \vec{p} \rangle} q) = \text{evl}_\alpha(\text{evl}_\alpha(\mathfrak{X}, \vec{Q}^{\vec{B}} \vec{p}. Q^{\Theta \cup \langle S; \vec{p} \rangle} \vec{q}), Q^{\Theta \cup \langle S; \vec{p} \rangle} q) \quad (2a)$$

$$\sqsubseteq \text{evl}_\alpha(\text{evl}_\alpha(\mathfrak{X}, Q^{\Theta} \vec{q}. \vec{Q}^{\vec{B}} \vec{p}), Q^{\Theta \cup \langle S; \vec{p} \rangle} q) \quad (2b)$$

$$= \text{evl}_\alpha(\text{evl}_\alpha(\mathfrak{X}, Q^{\Theta} \vec{q}), \vec{Q}^{\vec{B}} \vec{p}. Q^{\Theta \cup \langle S; \vec{p} \rangle} q) \quad (2c)$$

$$\sqsubseteq \text{evl}_\alpha(\text{evl}_\alpha(\mathfrak{X}, Q^{\Theta} \vec{q}), Q^\Theta q. \vec{Q}^{\vec{B}} \vec{p}) \quad (2d)$$

$$= \text{evl}_\alpha(\mathfrak{X}, Q^{\Theta} \vec{q}. Q^\Theta q. \vec{Q}^{\vec{B}} \vec{p}). \quad (2e)$$

Steps 2a, 2c, and 2e are due to the definition of evolution function of a quantifier prefix, Step 2b is just an application of the inductive hypothesis to the inner evolution function combined with the monotonicity property of Proposition 5, and, finally, Step 2d is due to the previously proved inequality  $\text{evl}_\alpha(\mathfrak{X}, \vec{Q}^{\vec{B}} \vec{p}. Q^{\Theta \cup \langle S; \vec{p} \rangle} q) \sqsubseteq \text{evl}_\alpha(\mathfrak{X}, Q^\Theta q. \vec{Q}^{\vec{B}} \vec{p})$  applied to the outer evolution function.  $\square$

Towards the proof of Proposition 6, we show the following more general result.

**Proposition 12.** *Let  $\mathfrak{X} \in \text{HAsg}$  be an hyperassignment and  $\wp, \wp_1, \wp_2, \wp_3 \in \text{Qn}_B$  behavioral quantifier prefixes, such that  $\wp = \wp_1 \cdot \wp_2 \cdot \wp_3$  and  $\text{ap}(\wp) \cap \text{ap}(\mathfrak{X}) = \emptyset$ . Then, it holds that  $\text{evl}_\alpha(\mathfrak{X}, C_{\vec{\alpha}}(\wp)) \sqsubseteq \text{evl}_\alpha(\mathfrak{X}, \wp_1 \cdot C_{\vec{\alpha}}(\wp_2) \cdot \wp_3) \sqsubseteq \text{evl}_\alpha(\mathfrak{X}, \wp) \sqsubseteq \text{evl}_\alpha(\mathfrak{X}, \wp_1 \cdot C_\alpha(\wp_2) \cdot \wp_3) \sqsubseteq \text{evl}_\alpha(\mathfrak{X}, C_\alpha(\wp))$ .*

**PROOF.** We separately prove the two chains of inequalities forming the statement, namely  $\text{evl}_\alpha(\mathfrak{X}, C_{\vec{\alpha}}(\wp)) \sqsubseteq \text{evl}_\alpha(\mathfrak{X}, \wp_1 \cdot C_{\vec{\alpha}}(\wp_2) \cdot \wp_3) \sqsubseteq \text{evl}_\alpha(\mathfrak{X}, \wp)$  and  $\text{evl}_\alpha(\mathfrak{X}, \wp) \sqsubseteq \text{evl}_\alpha(\mathfrak{X}, \wp_1 \cdot C_\alpha(\wp_2) \cdot \wp_3) \sqsubseteq \text{evl}_\alpha(\mathfrak{X}, C_\alpha(\wp))$ , by using different technical expedients.

- $[\text{evl}_\alpha(\mathfrak{X}, C_{\vec{\alpha}}(\wp)) \sqsubseteq \text{evl}_\alpha(\mathfrak{X}, \wp_1 \cdot C_{\vec{\alpha}}(\wp_2) \cdot \wp_3) \sqsubseteq \text{evl}_\alpha(\mathfrak{X}, \wp)]$  To prove that the first chain of inequalities holds, let us fix a well-founded preorder  $\leq$  over the set of triples of quantifier prefixes  $\mathcal{T} = \{ \langle \wp_1, \wp_2, \wp_3 \rangle \in \text{Qn}_B \times \text{Qn}_B \times \text{Qn}_B \mid \wp = \wp_1 \cdot \wp_2 \cdot \wp_3 \}$  defined as follows:  $\langle \wp_1, \wp_2, \wp_3 \rangle \leq \langle \wp'_1, \wp'_2, \wp'_3 \rangle$  iff  $\wp'_2 = \wp_l \cdot \wp_2 \cdot \wp_r$ , for some  $\wp_l, \wp_r \in \text{Qn}_B$ , i.e.,  $\wp_2$  is a (not necessarily proper) infix of  $\wp'_2$ . Notice that, given the definition of the set  $\mathcal{T}$ , the relation  $\langle \wp_1, \wp_2, \wp_3 \rangle \leq \langle \wp'_1, \wp'_2, \wp'_3 \rangle$  also implies  $\wp_1 = \wp'_1 \cdot \wp_l$  and  $\wp_3 = \wp_r \cdot \wp'_3$ . In addition, let us introduce  $C_{\vec{\alpha}}(T)$  as an abbreviation for  $\wp_1 \cdot C_{\vec{\alpha}}(\wp_2) \cdot \wp_3$ , given an arbitrary triple  $T = \langle \wp_1, \wp_2, \wp_3 \rangle \in \mathcal{T}$ . Now, to show that the chain of inequalities holds true, it is enough to prove that  $\text{evl}_\alpha(\mathfrak{X}, C_{\vec{\alpha}}(T')) \sqsubseteq \text{evl}_\alpha(\mathfrak{X}, C_{\vec{\alpha}}(T))$ , for all  $T, T' \in \mathcal{T}$  with  $T \leq T'$ . The proof shall proceed by structural induction on the preorder  $\leq$ .

- **[Base case  $T = T'$ ]** Obviously  $C_{\bar{\alpha}}(T) = C_{\bar{\alpha}}(T')$ . Thus, the property trivially holds, as  $\text{evl}_{\alpha}(\mathfrak{X}, C_{\bar{\alpha}}(T')) = \text{evl}_{\alpha}(\mathfrak{X}, C_{\bar{\alpha}}(T))$ .
- **[Inductive case  $T < T'$ ]** Since  $T < T'$ , there necessarily exists a triple  $T'' = \langle \wp_1'', \wp_2'', \wp_3'' \rangle \in \mathcal{T}$  such that  $T < T'' \leq T'$  and either (a)  $\wp_1 = \wp_1'' \cdot Q^{\text{B}}p$ ,  $\wp_2'' = Q^{\text{B}}p \cdot \wp_2$ , and  $\wp_3 = \wp_3''$ , or (b)  $\wp_1 = \wp_1''$ ,  $\wp_2'' = \wp_2 \cdot Q^{\text{B}}p$ , and  $\wp_3 = Q^{\text{B}}p \cdot \wp_3''$ , for some quantifier symbol  $Q \in \{\exists, \forall\}$  and atomic proposition  $p \in \text{AP}$ . By inductive hypothesis, it holds that  $\text{evl}_{\alpha}(\mathfrak{X}, C_{\bar{\alpha}}(T')) \sqsubseteq \text{evl}_{\alpha}(\mathfrak{X}, C_{\bar{\alpha}}(T''))$ . Thus, to conclude, we need to show that  $\text{evl}_{\alpha}(\mathfrak{X}, C_{\bar{\alpha}}(T'')) \sqsubseteq \text{evl}_{\alpha}(\mathfrak{X}, C_{\bar{\alpha}}(T))$ . If  $C_{\bar{\alpha}}(T) = C_{\bar{\alpha}}(T'')$ , there is nothing really to prove, as  $\text{evl}_{\alpha}(\mathfrak{X}, C_{\bar{\alpha}}(T'')) = \text{evl}_{\alpha}(\mathfrak{X}, C_{\bar{\alpha}}(T))$ . Hence, let us assume  $C_{\bar{\alpha}}(T) \neq C_{\bar{\alpha}}(T'')$ . The proof now proceeds with the following case analysis.

- (a) [ $\wp_1 = \wp_1'' \cdot Q^{\text{B}}p$ ,  $\wp_2'' = Q^{\text{B}}p \cdot \wp_2$ , **and**  $\wp_3 = \wp_3''$ ] First observe that  $Q$  is  $\alpha$ -coherent. If this were not the case, indeed, we would have had  $C_{\bar{\alpha}}(\wp_2'') = C_{\bar{\alpha}}(Q^{\text{B}}p \cdot \wp_2) = Q^{\text{B}}p \cdot C_{\bar{\alpha}}(\wp_2)$ , which in turn would have implied  $C_{\bar{\alpha}}(T'') = \wp_1'' \cdot C_{\bar{\alpha}}(\wp_2'') \cdot \wp_3'' = \wp_1'' \cdot C_{\bar{\alpha}}(Q^{\text{B}}p \cdot \wp_2) \cdot \wp_3'' = \wp_1'' \cdot Q^{\text{B}}p \cdot C_{\bar{\alpha}}(\wp_2) \cdot \wp_3'' = \wp_1 \cdot C_{\bar{\alpha}}(\wp_2) \cdot \wp_3 = C_{\bar{\alpha}}(T)$ , contradicting the previous assumption  $C_{\bar{\alpha}}(T) \neq C_{\bar{\alpha}}(T'')$ . Both  $C_{\bar{\alpha}}(\wp_2)$  and  $C_{\bar{\alpha}}(\wp_2'')$  are prefix canonicalisation, featuring at most one quantifier alternation starting with a  $\bar{\alpha}$ -coherent quantifier  $\bar{Q}$ . Specifically, these can be written as  $C_{\bar{\alpha}}(\wp_2) = \bar{Q}^{\text{B}}\vec{q} \cdot Q^{\text{B}}\vec{r}$  and  $C_{\bar{\alpha}}(\wp_2'') = C_{\bar{\alpha}}(Q^{\text{B}}p \cdot \wp_2) = \bar{Q}^{\text{B}}\vec{q} \cdot Q^{\text{BU}(\text{S}:\vec{q})}p \cdot Q^{\text{B}}\vec{r}$ , for some vectors of atomic propositions  $\vec{q}$  and  $\vec{r}$ , and a vector of quantifiers specifications  $\vec{\Theta} \in \mathbb{O}_{\text{B}}^*$  with  $|\vec{\Theta}| = |\vec{r}|$ . At this point, the induction proof terminates by checking the following chain of equalities/inequalities:

$$\text{evl}_{\alpha}(\mathfrak{X}, C_{\bar{\alpha}}(T'')) = \text{evl}_{\alpha}(\mathfrak{X}, \wp_1'' \cdot C_{\bar{\alpha}}(\wp_2'') \cdot \wp_3'') \quad (3a)$$

$$= \text{evl}_{\alpha}(\text{evl}_{\alpha}(\text{evl}_{\alpha}(\mathfrak{X}, \wp_1''), C_{\bar{\alpha}}(\wp_2'')), \wp_3'') \quad (3b)$$

$$= \text{evl}_{\alpha}(\text{evl}_{\alpha}(\text{evl}_{\alpha}(\mathfrak{X}, \wp_1''), \bar{Q}^{\text{B}}\vec{q} \cdot Q^{\text{BU}(\text{S}:\vec{q})}p \cdot Q^{\text{B}}\vec{r}), \wp_3'') \quad (3c)$$

$$= \text{evl}_{\alpha}(\text{evl}_{\alpha}(\text{evl}_{\alpha}(\mathfrak{X}, \wp_1''), \bar{Q}^{\text{B}}\vec{q} \cdot Q^{\text{BU}(\text{S}:\vec{q})}p), Q^{\text{B}}\vec{r} \cdot \wp_3'') \quad (3d)$$

$$\sqsubseteq \text{evl}_{\alpha}(\text{evl}_{\alpha}(\text{evl}_{\alpha}(\mathfrak{X}, \wp_1''), Q^{\text{B}}p \cdot \bar{Q}^{\text{B}}\vec{q}), Q^{\text{B}}\vec{r} \cdot \wp_3'') \quad (3e)$$

$$= \text{evl}_{\alpha}(\text{evl}_{\alpha}(\text{evl}_{\alpha}(\mathfrak{X}, \wp_1''), Q^{\text{B}}p \cdot \bar{Q}^{\text{B}}\vec{q} \cdot Q^{\text{B}}\vec{r}), \wp_3'') \quad (3f)$$

$$= \text{evl}_{\alpha}(\text{evl}_{\alpha}(\text{evl}_{\alpha}(\mathfrak{X}, \wp_1''), Q^{\text{B}}p), \bar{Q}^{\text{B}}\vec{q} \cdot Q^{\text{B}}\vec{r} \cdot \wp_3'') \quad (3g)$$

$$= \text{evl}_{\alpha}(\text{evl}_{\alpha}(\text{evl}_{\alpha}(\mathfrak{X}, \wp_1), C_{\bar{\alpha}}(\wp_2)), \wp_3) \quad (3h)$$

$$= \text{evl}_{\alpha}(\mathfrak{X}, \wp_1 \cdot C_{\bar{\alpha}}(\wp_2) \cdot \wp_3) \quad (3i)$$

$$= \text{evl}_{\alpha}(\mathfrak{X}, C_{\bar{\alpha}}(T)). \quad (3j)$$

Step 3e is due to Proposition 11 applied to  $\text{evl}_{\alpha}(\text{evl}_{\alpha}(\mathfrak{X}, \wp_1''), \bar{Q}^{\text{B}}\vec{q} \cdot Q^{\text{BU}(\text{S}:\vec{q})}p)$  combined with Proposition 5. All the other steps are just immediate consequences of the definition of evolution function and the structure of both the quantifier prefixes  $\wp_1''$ ,  $\wp_2''$ , and  $\wp_3''$ , and the canonical forms  $C_{\bar{\alpha}}(T)$  and  $C_{\bar{\alpha}}(T'')$ .

- (b) [ $\wp_1 = \wp_1''$ ,  $\wp_2'' = \wp_2 \cdot Q^{\text{B}}p$ , **and**  $\wp_3 = Q^{\text{B}}p \cdot \wp_3''$ ] Similarly to the previous case, from  $C_{\bar{\alpha}}(T) \neq C_{\bar{\alpha}}(T'')$ , one can derive that  $Q$  is  $\bar{\alpha}$ -coherent. Consequently,  $C_{\bar{\alpha}}(\wp_2)$  and  $C_{\bar{\alpha}}(\wp_2'')$  can be written as  $C_{\bar{\alpha}}(\wp_2) = Q^{\text{B}}\vec{q} \cdot \bar{Q}^{\text{B}}\vec{r}$  and  $C_{\bar{\alpha}}(\wp_2'') = C_{\bar{\alpha}}(\wp_2 \cdot Q^{\text{B}}p) = Q^{\text{B}}\vec{q} \cdot Q^{\text{B}}p \cdot \bar{Q}^{\text{B}}\vec{r}$ , for some vectors of atomic propositions  $\vec{q}$  and  $\vec{r}$ , and vectors of quantifiers specifications  $\vec{\Theta}, \vec{\Theta}' \in \mathbb{O}_{\text{B}}^*$  with  $|\vec{\Theta}| = |\vec{\Theta}'| = |\vec{r}|$  and  $\vec{\Theta}' = \vec{\Theta} \cup \{\text{S} : p\}$ . At this point, the induction proof terminates by checking the following chain of equalities/inequalities:

$$\text{evl}_{\alpha}(\mathfrak{X}, C_{\bar{\alpha}}(T'')) = \text{evl}_{\alpha}(\mathfrak{X}, \wp_1'' \cdot C_{\bar{\alpha}}(\wp_2'') \cdot \wp_3'') \quad (4a)$$

$$= \text{evl}_{\alpha}(\text{evl}_{\alpha}(\text{evl}_{\alpha}(\mathfrak{X}, \wp_1''), C_{\bar{\alpha}}(\wp_2'')), \wp_3'') \quad (4b)$$



$$= \text{evl}_\alpha(\text{evl}_\alpha(\text{evl}_\alpha(\mathfrak{X}, \wp_1''), Q^{\text{B}\bar{q}}. Q^{\text{B}p}. \bar{Q}^{\bar{\wp}'}, \wp_3'')) \quad (4c)$$

$$= \text{evl}_\alpha(\text{evl}_\alpha(\text{evl}_\alpha(\mathfrak{X}, \wp_1'' \cdot Q^{\text{B}\bar{q}}, Q^{\text{B}p}. \bar{Q}^{\bar{\wp}'}, \wp_3'')) \quad (4d)$$

$$\sqsubseteq \text{evl}_\alpha(\text{evl}_\alpha(\text{evl}_\alpha(\mathfrak{X}, \wp_1'' \cdot Q^{\text{B}\bar{q}}, \bar{Q}^{\bar{\wp}'}. Q^{\text{B}p}), \wp_3'')) \quad (4e)$$

$$= \text{evl}_\alpha(\text{evl}_\alpha(\text{evl}_\alpha(\mathfrak{X}, \wp_1''), Q^{\text{B}\bar{q}}. \bar{Q}^{\bar{\wp}'}. Q^{\text{B}p}), \wp_3'')) \quad (4f)$$

$$= \text{evl}_\alpha(\text{evl}_\alpha(\text{evl}_\alpha(\mathfrak{X}, \wp_1''), Q^{\text{B}\bar{q}}. \bar{Q}^{\bar{\wp}'}, Q^{\text{B}p}. \wp_3'')) \quad (4g)$$

$$= \text{evl}_\alpha(\text{evl}_\alpha(\text{evl}_\alpha(\mathfrak{X}, \wp_1), C_{\bar{\alpha}}(\wp_2)), \wp_3) \quad (4h)$$

$$= \text{evl}_\alpha(\mathfrak{X}, \wp_1. C_{\bar{\alpha}}(\wp_2). \wp_3) \quad (4i)$$

$$= \text{evl}_\alpha(\mathfrak{X}, C_{\bar{\alpha}}(T)). \quad (4j)$$

Step 4e is due to Proposition 11 applied to  $\text{evl}_\alpha(\text{evl}_\alpha(\mathfrak{X}, \wp_1''), Q^{\text{B}\bar{q}}, Q^{\text{B}p}. \bar{Q}^{\bar{\wp}'}, \wp_3'')$  combined with Proposition 5. All the other steps are just immediate consequences of the definition of evolution function and the structure of both the quantifier prefixes  $\wp_1'', \wp_2'',$  and  $\wp_3'',$  and the canonical forms  $C_{\bar{\alpha}}(T)$  and  $C_{\bar{\alpha}}(T'')$ .

- $[\text{evl}_\alpha(\mathfrak{X}, \wp) \sqsubseteq \text{evl}_\alpha(\mathfrak{X}, \wp_1. C_{\bar{\alpha}}(\wp_2). \wp_3) \sqsubseteq \text{evl}_\alpha(\mathfrak{X}, C_\alpha(\wp))]$  In order to show that the second chain of inequalities holds as well, we first state the following two simple auxiliary results, one regarding a duality property between the two syntactic canonicalisations of a quantifier prefix and the other concerning the dualization of the evolution function.

**Claim 9.**  $\overline{C_\alpha(\wp)} = C_{\bar{\alpha}}(\bar{\wp})$ , for all quantifier prefixes  $\wp \in \text{Qn}$ .

**Claim 10.**  $\text{evl}_\alpha(\mathfrak{X}, \wp) \equiv \text{evl}_\alpha(\mathfrak{X}, \bar{\wp})$ , for all hyperassignments  $\mathfrak{X} \in \text{HASg}$  and quantifier prefixes  $\wp \in \text{Qn}$ .

**PROOF.** The proof proceeds by induction on the length of  $\wp$ .

– [Base step  $\wp = \varepsilon$ ]  $\overline{\text{evl}_\alpha(\mathfrak{X}, \varepsilon)} = \bar{\mathfrak{X}} = \text{evl}_\alpha(\bar{\mathfrak{X}}, \varepsilon)$ .

– [Inductive step  $\wp = Q^\Theta p. \wp'$ ] First notice that  $\bar{\wp} = \bar{Q}^\Theta p. \bar{\wp}'$  and observe that, thanks to the definition of evolution function and the inductive hypothesis, the following holds true:

$$\overline{\text{evl}_\alpha(\mathfrak{X}, \wp)} = \overline{\text{evl}_\alpha(\text{evl}_\alpha(\mathfrak{X}, Q^\Theta p), \wp')} \equiv \text{evl}_\alpha(\overline{\text{evl}_\alpha(\mathfrak{X}, Q^\Theta p)}, \bar{\wp}').$$

Let us now distinguish two cases based on the coherence of  $\alpha$  and  $Q$ .

\* [Q is  $\alpha$ -coherent]

$$\overline{\text{evl}_\alpha(\mathfrak{X}, \wp)} \equiv \text{evl}_\alpha(\overline{\text{evl}_\alpha(\mathfrak{X}, Q^\Theta p)}, \bar{\wp}') \quad (5a)$$

$$= \text{evl}_\alpha(\overline{\text{ext}_\Theta(\mathfrak{X}, p)}, \bar{\wp}') \quad (5b)$$

$$\equiv \text{evl}_\alpha(\overline{\text{ext}_\Theta(\bar{\mathfrak{X}}, p)}, \bar{\wp}') \quad (5c)$$

$$= \text{evl}_\alpha(\text{evl}_\alpha(\bar{\mathfrak{X}}, \bar{Q}^\Theta p), \bar{\wp}') \quad (5d)$$

$$= \text{evl}_\alpha(\bar{\mathfrak{X}}, \bar{Q}^\Theta p. \bar{\wp}') \quad (5e)$$

$$= \text{evl}_\alpha(\bar{\mathfrak{X}}, \bar{\wp}) \quad (5f)$$

Step 5b and 5d are due to the definition of evolution function over a single quantifier, for the cases when  $\alpha$  and  $Q$  are coherent and non-coherent, respectively. Step 5c is just a simple consequence of Propositions 1, 4, and 5. Finally, Step 5e is given by the definition of evolution function for quantifier prefixes.

\* [Q is not  $\alpha$ -coherent]

$$\overline{\text{evl}_\alpha(\mathfrak{X}, \wp)} \equiv \text{evl}_\alpha(\overline{\text{evl}_\alpha(\mathfrak{X}, \text{Q}^\ominus p)}, \overline{\wp'}) \quad (6a)$$

$$= \text{evl}_\alpha(\overline{\text{ext}_\Theta(\overline{\mathfrak{X}}, p)}, \overline{\wp'}) \quad (6b)$$

$$\equiv \text{evl}_\alpha(\text{ext}_\Theta(\overline{\mathfrak{X}}, p), \overline{\wp'}) \quad (6c)$$

$$= \text{evl}_\alpha(\text{evl}_\alpha(\overline{\mathfrak{X}}, \overline{\text{Q}^\ominus p}), \overline{\wp'}) \quad (6d)$$

$$= \text{evl}_\alpha(\overline{\mathfrak{X}}, \overline{\text{Q}^\ominus p} \cdot \overline{\wp'}) \quad (6e)$$

$$= \text{evl}_\alpha(\overline{\mathfrak{X}}, \overline{\wp}) \quad (6f)$$

Step 6b and 6d are due to the definition of evolution function over a single quantifier, for the cases when  $\alpha$  and Q are non-coherent and coherent, respectively. Step 6c is just a simple consequence of Propositions 1 and 5. Finally, Step 6e is given by the definition of evolution function for quantifier prefixes.  $\square$

In the first item of this proof, we have proved that  $\text{evl}_\alpha(\mathfrak{X}, C_{\overline{\alpha}}(\wp)) \sqsubseteq \text{evl}_\alpha(\mathfrak{X}, \wp_1 \cdot C_{\overline{\alpha}}(\wp_2) \cdot \wp_3) \sqsubseteq \text{evl}_\alpha(\mathfrak{X}, \wp)$  holds true for every  $\mathfrak{X} \in \text{HASg}$  and  $\wp, \wp_1, \wp_2, \wp_3 \in \text{Qn}_B$ , with  $\wp = \wp_1 \cdot \wp_2 \cdot \wp_3$ . By instantiating  $\mathfrak{X}$  and  $\wp$  with  $\overline{\mathfrak{X}}$  and  $\overline{\wp}$ , and observing that  $\overline{\wp} = \overline{\wp_1} \cdot \overline{\wp_2} \cdot \overline{\wp_3}$ , we obtain  $\text{evl}_\alpha(\overline{\mathfrak{X}}, C_{\overline{\alpha}}(\overline{\wp})) \sqsubseteq \text{evl}_\alpha(\overline{\mathfrak{X}}, \overline{\wp_1} \cdot C_{\overline{\alpha}}(\overline{\wp_2}) \cdot \overline{\wp_3}) \sqsubseteq \text{evl}_\alpha(\overline{\mathfrak{X}}, \overline{\wp})$ . Now, thanks to Claims 9 and 10 above, we obtain  $\text{evl}_\alpha(\mathfrak{X}, C_\alpha(\wp)) \sqsubseteq \text{evl}_\alpha(\mathfrak{X}, \wp_1 \cdot C_\alpha(\wp_2) \cdot \wp_3) \sqsubseteq \text{evl}_\alpha(\mathfrak{X}, \wp)$ , as shown in the following two chains of equivalences/inequalities:

$$\overline{\text{evl}_\alpha(\mathfrak{X}, C_\alpha(\wp))} \equiv \text{evl}_\alpha(\overline{\mathfrak{X}}, \overline{C_\alpha(\wp)}) \quad (7a)$$

$$= \text{evl}_\alpha(\overline{\mathfrak{X}}, \overline{C_{\overline{\alpha}}(\overline{\wp})}) \quad (7b)$$

$$\sqsubseteq \text{evl}_\alpha(\overline{\mathfrak{X}}, \overline{\wp_1} \cdot \overline{C_{\overline{\alpha}}(\overline{\wp_2})} \cdot \overline{\wp_3}) \quad (7c)$$

$$= \text{evl}_\alpha(\overline{\mathfrak{X}}, \overline{\wp_1} \cdot \overline{C_\alpha(\wp_2)} \cdot \overline{\wp_3}) \quad (7d)$$

$$= \text{evl}_\alpha(\overline{\mathfrak{X}}, \overline{\wp_1} \cdot C_\alpha(\wp_2) \cdot \wp_3) \quad (7e)$$

$$\equiv \overline{\text{evl}_\alpha(\mathfrak{X}, \wp_1 \cdot C_\alpha(\wp_2) \cdot \wp_3)}. \quad (7f)$$

$$\overline{\text{evl}_\alpha(\mathfrak{X}, \wp_1 \cdot C_\alpha(\wp_2) \cdot \wp_3)} \equiv \text{evl}_\alpha(\overline{\mathfrak{X}}, \overline{\wp_1 \cdot C_\alpha(\wp_2) \cdot \wp_3}) \quad (7g)$$

$$= \text{evl}_\alpha(\overline{\mathfrak{X}}, \overline{\wp_1} \cdot \overline{C_\alpha(\wp_2)} \cdot \overline{\wp_3}) \quad (7h)$$

$$= \text{evl}_\alpha(\overline{\mathfrak{X}}, \overline{\wp_1} \cdot \overline{C_{\overline{\alpha}}(\overline{\wp_2})} \cdot \overline{\wp_3}) \quad (7i)$$

$$\sqsubseteq \text{evl}_\alpha(\overline{\mathfrak{X}}, \overline{\wp}) \quad (7j)$$

$$\equiv \overline{\text{evl}_\alpha(\mathfrak{X}, \wp)}. \quad (7k)$$

At this point, thanks to Propositions 1 and 4, we derive  $\text{evl}_\alpha(\mathfrak{X}, \wp) \sqsubseteq \text{evl}_\alpha(\mathfrak{X}, \wp_1 \cdot C_\alpha(\wp_2) \cdot \wp_3) \sqsubseteq \text{evl}_\alpha(\mathfrak{X}, C_\alpha(\wp))$  from  $\overline{\text{evl}_\alpha(\mathfrak{X}, C_\alpha(\wp))} \sqsubseteq \overline{\text{evl}_\alpha(\mathfrak{X}, \wp_1 \cdot C_\alpha(\wp_2) \cdot \wp_3)} \sqsubseteq \overline{\text{evl}_\alpha(\mathfrak{X}, \wp)}$ .  $\square$

The following proposition is now an immediate consequence of the above result.

**Proposition 6.**  $\text{evl}_\alpha(\mathfrak{X}, C_{\overline{\alpha}}(\wp)) \sqsubseteq \text{evl}_\alpha(\mathfrak{X}, \wp) \sqsubseteq \text{evl}_\alpha(\mathfrak{X}, C_\alpha(\wp))$ , for all hyperassignments  $\mathfrak{X} \in \text{HASg}$  and behavioral quantifier prefixes  $\wp \in \text{Qn}_B$ , with  $\text{ap}(\wp) \cap \text{ap}(\mathfrak{X}) = \emptyset$ .



- **[Base step  $\wp = \varepsilon$ ]**  $\text{evl}_\alpha(\mathfrak{X}_1, \varepsilon) = \mathfrak{X}_1 \sqsubseteq_X \mathfrak{X}_2 = \text{evl}_\alpha(\mathfrak{X}_2, \varepsilon)$ .
- **[Inductive step  $\wp = Q^\Theta p, \wp'$ ]** Let us distinguish two cases based on whether  $Q$  is or not  $\alpha$ -coherent.
  - **[ $Q$  is  $\alpha$ -coherent]** Since  $\alpha$  and  $Q$  are coherent,  $\text{evl}_\alpha(\mathfrak{X}_i, \wp) = \text{evl}_\alpha(\text{ext}_\Theta(\mathfrak{X}_i, p), \wp')$ , for all  $i \in \{1, 2\}$ . We can now focus on showing that  $\text{ext}_\Theta(\mathfrak{X}_1, p) \sqsubseteq_X \text{ext}_\Theta(\mathfrak{X}_2, p)$  holds true, as the thesis follows by applying the inductive hypothesis. Since  $\text{ext}_\Theta(\mathfrak{X}_i, p) = \{\text{ext}(X_i, F_i, p) \mid X_i \in \mathfrak{X}_i, F_i \in \text{Fnc}_\Theta(\text{ap}(\mathfrak{X}_i))\}$ , we have to prove that, for every  $X_1 \in \mathfrak{X}_1$  and  $F_1 \in \text{Fnc}_\Theta(\text{ap}(\mathfrak{X}_1))$ , there exist  $X_2 \in \mathfrak{X}_2$  and  $F_2 \in \text{Fnc}_\Theta(\text{ap}(\mathfrak{X}_2))$  such that  $\text{ext}(X_2, F_2, p) \setminus \{\chi \in \text{Asg} \mid \chi \upharpoonright_P \in X\} \subseteq \text{ext}(X_1, F_1, p)$ . Now, it is easy to see that such a property can be satisfied by choosing  $F_2 \triangleq F_1$ , since  $\text{Fnc}_\Theta(\text{ap}(\mathfrak{X}_1)) = \text{Fnc}_\Theta(\text{ap}(\mathfrak{X}_2))$ , and  $\mathfrak{X}_2 \triangleq f(\mathfrak{X}_1)$ , where  $f: \mathfrak{X}_1 \rightarrow \mathfrak{X}_2$  is a witness for the inclusion  $\mathfrak{X}_1 \sqsubseteq_X \mathfrak{X}_2$ .
  - **[ $Q$  is not  $\alpha$ -coherent]** Since  $\alpha$  and  $Q$  are not coherent, by Propositions 5 and 9, it holds that  $\text{evl}_\alpha(\mathfrak{X}_i, \wp) = \text{evl}_\alpha(\text{evl}_\alpha(\mathfrak{X}_i, Q^\Theta p), \wp') \equiv \text{evl}_\alpha(\text{nevl}_\alpha(\mathfrak{X}_i, Q^\Theta p), \wp')$ , for all  $i \in \{1, 2\}$ . As done in the previous case, we can now focus on showing that  $\text{nevl}_\alpha(\mathfrak{X}_1, Q^\Theta p) \sqsubseteq_X \text{nevl}_\alpha(\mathfrak{X}_2, Q^\Theta p)$  holds true, as the thesis follows by applying the inductive hypothesis. Since  $\text{nevl}_\alpha(\mathfrak{X}_i, Q^\Theta p) = \{\text{ext}(\bar{\partial}_i, p) \mid \bar{\partial}_i \in \text{Fnc}_\Theta(\text{ap}(\mathfrak{X}_i)) \rightarrow \mathfrak{X}_i\}$ , we have to prove that, for every  $\bar{\partial}_1 \in \text{Fnc}_\Theta(\text{ap}(\mathfrak{X}_1)) \rightarrow \mathfrak{X}_1$ , there exists  $\bar{\partial}_2 \in \text{Fnc}_\Theta(\text{ap}(\mathfrak{X}_2)) \rightarrow \mathfrak{X}_2$  such that  $\text{ext}(\bar{\partial}_2, p) \setminus \{\chi \in \text{Asg} \mid \chi \upharpoonright_P \in X\} \subseteq \text{ext}(\bar{\partial}_1, p)$ . To this end, let us define a function  $g: (\text{Fnc}_\Theta(\text{ap}(\mathfrak{X}_1)) \rightarrow \mathfrak{X}_1) \rightarrow (\text{Fnc}_\Theta(\text{ap}(\mathfrak{X}_2)) \rightarrow \mathfrak{X}_2)$  as follows:  $g(\bar{\partial}_1)(F) \triangleq f(\bar{\partial}_1(F))$ , for every  $\bar{\partial}_1 \in \text{Fnc}_\Theta(\text{ap}(\mathfrak{X}_1)) \rightarrow \mathfrak{X}_1$  and  $F \in \text{Fnc}_\Theta(\text{ap}(\mathfrak{X}_1)) = \text{Fnc}_\Theta(\text{ap}(\mathfrak{X}_2))$ , where  $f: \mathfrak{X}_1 \rightarrow \mathfrak{X}_2$  is a witness for the inclusion  $\mathfrak{X}_1 \sqsubseteq_X \mathfrak{X}_2$ . Clearly, it holds that  $g(\bar{\partial}_1)(F) \setminus \{\chi \in \text{Asg} \mid \chi \upharpoonright_P \in X\} \subseteq \bar{\partial}_1(F)$ . Thus, the required property can be satisfied by choosing  $\bar{\partial}_2 \triangleq g(\bar{\partial}_1)$ , since  $\text{ext}(g(\bar{\partial}_1), p) \setminus \{\chi \in \text{Asg} \mid \chi \upharpoonright_P \in X\} \subseteq \text{ext}(\bar{\partial}_1, p)$  holds true.  $\square$

Next, we prove Theorem 8. Here is the graph of dependency presenting the theorem and the propositions used for this proof.

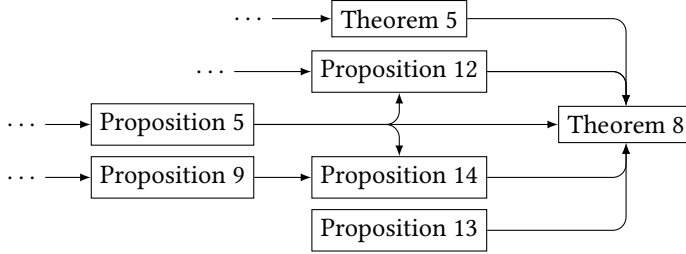

**Theorem 8** (Quantification Game II). *Every  $\Omega$ -game  $\wp$ , for some quantification-game schema  $\Omega \triangleq (\mathfrak{X}, \wp, \Psi)$ , satisfies the following two properties:*

- 1) *if Eloise wins then  $E \subseteq \Psi$ , for some  $E \in \text{evl}_{\exists\forall}(\mathfrak{X}, C_{\forall\exists}(\wp))$ ;*
- 2) *if Abelard wins then  $E \not\subseteq \Psi$ , for all  $E \in \text{evl}_{\exists\forall}(\mathfrak{X}, C_{\exists\forall}(\wp))$ .*

**PROOF.** First of all, recall that the game  $\wp_\Omega$  of Construction 2 is obtained directly from the game  $\wp_\Psi$  of Construction 1, by defining the set of assignments  $\widehat{\wp}$  and the quantifier prefix  $\widehat{\Psi}$  as follows:

- $\widehat{\wp} \triangleq \forall \vec{p}. \widehat{\wp}. \wp$  and
- $\widehat{\Psi} \triangleq \Psi \cup \{\chi \in \text{Asg}(P) \mid \chi \upharpoonright_{\vec{p}} \notin X\}$ ,

with  $\vec{p} \triangleq \text{ap}(\mathfrak{X}) \setminus \text{ap}(\widehat{\wp})$  and  $P \triangleq \text{ap}(\wp) \cup \text{ap}(\mathfrak{X})$ .

We can now proceed with the proof of the two properties.

- [1] If Eloise wins the game, by Item 1 of Theorem 5, there exists a set of assignments  $\widehat{E} \in \text{eval}_{\exists\forall}(\text{C}_{\forall\exists}(\widehat{\varphi}))$  such that  $\widehat{E} \sqsubseteq \widehat{\Psi}$ . Thanks to Propositions 5 and 12, we can show that  $\text{eval}_{\exists\forall}(\text{C}_{\forall\exists}(\widehat{\varphi})) \sqsubseteq \text{eval}_{\exists\forall}(\mathfrak{X}, \text{C}_{\forall\exists}(\varphi))$ . Indeed,

$$\text{eval}_{\exists\forall}(\text{C}_{\forall\exists}(\widehat{\varphi})) = \text{eval}_{\exists\forall}(\text{C}_{\forall\exists}(\forall\vec{p}. \widehat{\varphi}. \varphi)) \quad (8a)$$

$$\sqsubseteq \text{eval}_{\exists\forall}(\forall\vec{p}. \widehat{\varphi}. \text{C}_{\forall\exists}(\varphi)) \quad (8b)$$

$$= \text{eval}_{\exists\forall}(\text{eval}_{\exists\forall}(\text{eval}_{\exists\forall}(\forall\vec{p}), \widehat{\varphi}), \text{C}_{\forall\exists}(\varphi)) \quad (8c)$$

$$= \text{eval}_{\exists\forall}(\text{eval}_{\exists\forall}(\{\text{Asg}(\vec{p})\}, \widehat{\varphi}), \text{C}_{\forall\exists}(\varphi)) \quad (8d)$$

$$\sqsubseteq \text{eval}_{\exists\forall}(\text{eval}_{\exists\forall}(\{X\}, \widehat{\varphi}), \text{C}_{\forall\exists}(\varphi)) \quad (8e)$$

$$= \text{eval}_{\exists\forall}(\mathfrak{X}, \text{C}_{\forall\exists}(\varphi)), \quad (8f)$$

where Step 8b is due to Proposition 12, Step 8d to the equality  $\text{eval}_{\exists\forall}(\forall\vec{p}) = \{\text{Asg}(\vec{p})\}$ , and Step 8e is derived from Proposition 5, thanks to the fact that  $\{\text{Asg}(\vec{p})\} \sqsubseteq \{X\}$ . Now, due to the definition of the ordering  $\sqsubseteq$  between hyperassignments, it follows that  $\text{eval}_{\exists\forall}(\text{C}_{\forall\exists}(\widehat{\varphi})) \sqsubseteq \text{eval}_{\exists\forall}(\mathfrak{X}, \text{C}_{\forall\exists}(\varphi))$  necessarily implies the existence of a set of assignments  $E \in \text{eval}_{\exists\forall}(\mathfrak{X}, \text{C}_{\forall\exists}(\varphi))$  such that  $E \sqsubseteq \widehat{E}$ . Therefore,  $E \sqsubseteq \widehat{\Psi}$ . At this point, we can prove that  $E \sqsubseteq \Psi$ , since  $\widehat{\Psi} = \Psi \cup \{\chi \in \text{Asg}(P) \mid \chi \upharpoonright_{\vec{p}} \notin X\}$  and  $E \cap \{\chi \in \text{Asg}(P) \mid \chi \upharpoonright_{\vec{p}} \notin X\} = \emptyset$ . Indeed,  $E \in \text{eval}_{\exists\forall}(\mathfrak{X}, \text{C}_{\forall\exists}(\varphi)) = \text{eval}_{\exists\forall}(\{X\}, \widehat{\varphi}. \text{C}_{\forall\exists}(\varphi))$  and, by Proposition 13, it follows that  $E \upharpoonright_{\vec{p}} \subseteq X$ .

- [2] If Abelard wins the game, by Item 2 of Theorem 5, it holds that  $\widehat{E} \not\sqsubseteq \widehat{\Psi}$ , for all sets of assignments  $\widehat{E} \in \text{eval}_{\exists\forall}(\text{C}_{\exists\forall}(\widehat{\varphi}))$ . It is easy to observe that  $\{X\} \sqsubseteq_{\overline{X}} \{\text{Asg}(\vec{p})\}$ , since  $\text{Asg}(\vec{p}) \setminus \{\chi \in \text{Asg} \mid \chi \upharpoonright_{\vec{p}} \in \overline{X}\} = \text{Asg}(\vec{p}) \setminus \{\chi \in \text{Asg} \mid \chi \upharpoonright_{\vec{p}} \notin X\} = X$ . Thus, thanks to Propositions 12 and 14, we can show that  $\text{eval}_{\exists\forall}(\mathfrak{X}, \text{C}_{\exists\forall}(\varphi)) \sqsubseteq_{\overline{X}} \text{eval}_{\exists\forall}(\text{C}_{\exists\forall}(\widehat{\varphi}))$ . Indeed,

$$\text{eval}_{\exists\forall}(\mathfrak{X}, \text{C}_{\exists\forall}(\varphi)) = \text{eval}_{\exists\forall}(\text{eval}_{\exists\forall}(\{X\}, \widehat{\varphi}), \text{C}_{\exists\forall}(\varphi)) \quad (9a)$$

$$\sqsubseteq_{\overline{X}} \text{eval}_{\exists\forall}(\text{eval}_{\exists\forall}(\{\text{Asg}(\vec{p})\}, \widehat{\varphi}), \text{C}_{\exists\forall}(\varphi)) \quad (9b)$$

$$= \text{eval}_{\exists\forall}(\text{eval}_{\exists\forall}(\text{eval}_{\exists\forall}(\forall\vec{p}), \widehat{\varphi}), \text{C}_{\exists\forall}(\varphi)) \quad (9c)$$

$$= \text{eval}_{\exists\forall}(\forall\vec{p}. \widehat{\varphi}. \text{C}_{\exists\forall}(\varphi)) \quad (9d)$$

$$\sqsubseteq \text{eval}_{\exists\forall}(\text{C}_{\exists\forall}(\forall\vec{p}. \widehat{\varphi}. \varphi)) \quad (9e)$$

$$= \text{eval}_{\exists\forall}(\text{C}_{\exists\forall}(\widehat{\varphi})), \quad (9f)$$

where Step 9b is due to Proposition 14, thanks to the fact that  $\{X\} \sqsubseteq_{\overline{X}} \{\text{Asg}(\vec{p})\}$ , Step 9c to the equality  $\text{eval}_{\exists\forall}(\forall\vec{p}) = \{\text{Asg}(\vec{p})\}$ , and Step 9e is derived from Proposition 12. Now, due to the definition of the ordering  $\sqsubseteq_{\overline{X}}$  between hyperassignments, it follows that  $\text{eval}_{\exists\forall}(\mathfrak{X}, \text{C}_{\exists\forall}(\varphi)) \sqsubseteq_{\overline{X}} \text{eval}_{\exists\forall}(\text{C}_{\exists\forall}(\widehat{\varphi}))$  necessarily implies the non existence of a set of assignments  $E \in \text{eval}_{\exists\forall}(\mathfrak{X}, \text{C}_{\exists\forall}(\varphi))$  such that  $E \sqsubseteq \widehat{\Psi}$ . Indeed, assume towards a contradiction that there is  $E \in \text{eval}_{\exists\forall}(\mathfrak{X}, \text{C}_{\exists\forall}(\varphi))$  such that  $E \sqsubseteq \widehat{\Psi}$ . By the above inclusion, there is  $\widehat{E} \in \text{eval}_{\exists\forall}(\text{C}_{\exists\forall}(\widehat{\varphi}))$  such that  $\widehat{E} \setminus \{\chi \in \text{Asg} \mid \chi \upharpoonright_{\vec{p}} \in \overline{X}\} \subseteq E \subseteq \widehat{\Psi}$ . Since  $\widehat{E} \cap \{\chi \in \text{Asg} \mid \chi \upharpoonright_{\vec{p}} \in \overline{X}\} \subseteq \{\chi \in \text{Asg}(P) \mid \chi \upharpoonright_{\vec{p}} \notin X\} \subseteq \widehat{\Psi}$ , we have that  $\widehat{E} \subseteq \widehat{\Psi}$ , which contradicts the fact that Abelard wins the game. Hence,  $E \not\sqsubseteq \widehat{\Psi}$  holds, for all  $E \in \text{eval}_{\exists\forall}(\mathfrak{X}, \text{C}_{\exists\forall}(\varphi))$ , which implies that  $E \not\sqsubseteq \Psi$ , being  $\Psi \subseteq \widehat{\Psi}$ .  $\square$

Now, we have proven everything that is used for the proof of Theorem 9 from the main paper. Here is the graph of dependency presenting the lemma, the propositions, the corollaries and theorems used for this proof.

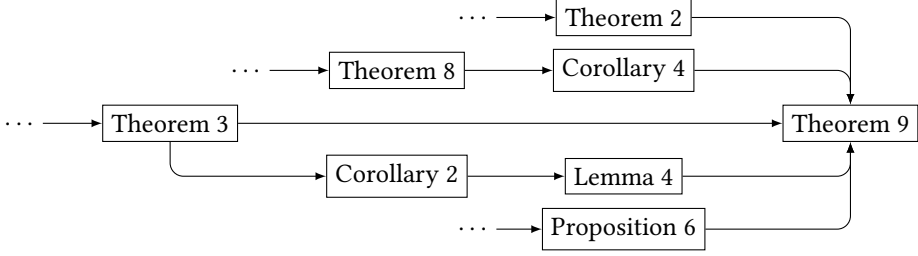

And finally, we have proven everything that is used for the proof of Theorem 7 from the main paper. Here is the graph of dependency presenting the corollary and the theorem used for this proof.

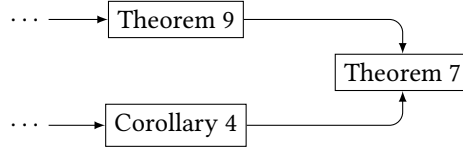

## D PROOFS OF SECTION 5

The following theorem relies on both the notions of parity game and parity automaton [14, 64, 65] (see also [26, 45]). Parity games are perfect-information two-player turn-based games of infinite duration, usually played on finite directed graphs. Their vertices, called positions, are labelled by natural numbers, called priorities, and are assigned to one of two players, namely 0 and 1. The game starts at a given position and, during its evolution, players can take a move (an outgoing edge) only at their own positions. The moves selected by the players induce an infinite sequence of vertices, called play. If the maximal priority of the vertices occurring infinitely often in the play is even, then the play is winning for player 0, otherwise, player 1 takes it all. Similarly, the states of a (non-deterministic) parity automaton are labelled with natural numbers (priorities) and an infinite word given in input is accepted by the automaton *iff* there exists a run induced by such a word, for which the maximal priority seen infinitely often along it has even parity.

**Theorem 10** (Satisfiability Game). *For every behavioral GFG-QPTL sentence  $\varphi$  there is a parity game, with  $2^{2^{O(|\varphi|)}}$  positions and  $2^{O(|\varphi|)}$  priorities, won by Eloise iff  $\varphi$  is satisfiable.*

**PROOF.** Let  $\varphi = \wp\psi$  be a behavioral GFG-QPTL sentence with  $\wp$  a quantification prefix and  $\psi$  an LTL formula. Additionally, let  $\Psi \triangleq \{\chi \in \text{Asg}(\text{ap}(\varphi)) \mid \chi \models \psi\}$ . The idea of the proof is to construct a parity game  $\mathcal{G}_\varphi$  that is equivalent to the game  $\mathcal{G}_\varphi^\Psi \triangleq \mathcal{G}_\varphi^\Psi \triangleq \langle \mathcal{A}_\varphi^\Psi, \text{Ob}_\varphi^\Psi, \text{Wn}_\varphi^\Psi \rangle$  defined in Construction 1, where  $\mathcal{A}_\varphi^\Psi \triangleq \langle \text{PsE}^{\wp,\psi}, \text{PsA}^{\wp,\psi}, \text{vI}^{\wp,\psi}, \text{Mv}^{\wp,\psi} \rangle$ . Intuitively,  $\mathcal{G}_\varphi$  simulates the synchronous product of arena  $\mathcal{A}_\varphi^\Psi$  with the deterministic automaton  $\mathcal{D}_\psi$  recognising models of  $\psi$ , where  $\mathcal{D}_\psi$  changes state only when Abelard takes a move starting from an observable position containing full valuation of the propositions. Such valuation determines the successor state.

The deterministic automaton  $\mathcal{D}_\psi$  recognising models of  $\psi$  can be obtained in a standard way, by first constructing a non-deterministic Büchi automaton  $A_\psi$  that recognises models of  $\psi$ , using the Vardi-Wolper construction [81], and then by determinising  $A_\psi$  (via a Safra-like determinisation procedure [69]) into an equivalent deterministic parity automaton  $\mathcal{D}_\psi = \langle Q, q_0, \Sigma, \delta, \text{Acc} \rangle$ , where

- $Q$  is the finite set of states,
- $q_0 \in Q$  is the initial state,
- $\Sigma = \text{Val}(\text{ap}(\varphi))$  is the alphabet,

- $\delta : Q \times \Sigma \rightarrow Q$  is the transition function,
- $\text{Acc} : Q \rightarrow \mathbb{N}$  is the parity condition.

Now, the parity game  $\mathcal{D}_\varphi$  associated with  $\varphi$  is a pair  $\mathcal{D}_\varphi \triangleq \langle \mathcal{A}_\varphi, \text{Wn}_\varphi \rangle$ , where:

- $\mathcal{A}_\varphi \triangleq \langle \text{Ps}_E^\varphi, \text{Ps}_A^\varphi, v_I^\varphi, Mv^\varphi \rangle$  is the arena;
- the set of positions  $\text{P}_S^\varphi \triangleq \text{Ps}_E^\varphi \uplus \text{Ps}_A^\varphi = Q \times (\text{Ps}_E^{\varphi, \psi} \cup \text{Ps}_A^{\varphi, \psi})$  contains exactly the pairs consisting of a state of the automaton  $\mathcal{D}_\psi$  and a valuation  $\xi \in \text{Val}$  which is a position of  $\mathcal{D}_\psi^\psi$ ;
- the set of Eloise's positions  $\text{Ps}_E^\varphi \subseteq \text{P}_S^\varphi$  only contains the positions  $(q, \xi) \in \text{P}_S^\varphi$  where  $\xi$  is an Eloise's position in  $\mathcal{D}_\psi^\psi$ ;
- the initial position  $v_I^\varphi \triangleq (q_0, \emptyset)$  is just the initial state of  $\mathcal{D}_\psi$  paired with the initial state of  $\mathcal{D}_\psi^\psi$ ;
- the move relation  $Mv^\varphi \subseteq \text{P}_S^\varphi \times \text{P}_S^\varphi$  contains exactly those pairs of positions  $((q_1, \xi_1), (q_2, \xi_2)) \in \text{P}_S^\varphi \times \text{P}_S^\varphi$  such that:
  - $(\xi_1, \xi_2)$  is a move in  $\mathcal{D}_\psi^\psi$ ;
  - if  $\xi_2 = \emptyset$  then  $q_2 = \delta(q_1, \xi_1)$ , otherwise,  $q_1 = q_2$ ;
- the winning condition  $\text{Wn}_\varphi$  is deduced from the accepting condition of the automaton  $\mathcal{D}_\psi$ . More precisely, the priority of a position  $(q, \xi) \in \text{P}_S^\varphi$  is defined as the priority  $\text{Acc}(q)$  of  $q$ , i.e.,  $\text{Wn}_\varphi((q, \xi)) = \text{Acc}(q)$  for all  $(q, \xi) \in \text{P}_S^\varphi$ .

We want to show that there is a strategy for Eloise to win  $\mathcal{D}_\varphi$  if and only if there is a strategy for her to win  $\mathcal{D}_\psi^\psi$ .

Towards the definition of a correspondence between Eloise's strategies in  $\mathcal{D}_\varphi$  and Eloise's strategies in  $\mathcal{D}_\psi^\psi$ , we define now a bijection  $f$  between initial paths on  $\mathcal{D}_\varphi$  (denoted  $\text{Pth}_{\text{init}}(\mathcal{D}_\varphi)$ ) and initial paths on  $\mathcal{D}_\psi^\psi$  (denoted  $\text{Pth}_{\text{init}}(\mathcal{D}_\psi^\psi)$ ). Given two sets  $S, S'$  and a pair  $(x, y) \in S \times S'$ , we let  $\text{proj}_1(x, y) = x$  and  $\text{proj}_2(x, y) = y$ , that is, functions  $\text{proj}_1$  and  $\text{proj}_2$  return the first and the second element of their argument, respectively. Furthermore, we denote by  $\tau \circ \pi \triangleq ((\tau)_0, (\pi)_0)((\tau)_1, (\pi)_1) \dots$  the *pairing product* of two sequences. Let  $\pi \in \text{Pth}_{\text{init}}(\mathcal{D}_\varphi)$ , with  $\pi$ , be an initial path on  $\mathcal{D}_\varphi$ . Function  $f$  maps  $\pi$  into the initial path on  $\mathcal{D}_\psi^\psi$  obtained by projecting on the second component of each position of  $\pi$ , that is,  $f(\pi) = \langle \text{proj}_2((\pi)_i) \rangle_{i \in [0, |\pi|)}$ . The fact that  $f$  is a bijection, as stated in Corollary 5, is an immediate consequence of the following claim.

**Claim 11.** *For every initial path  $\pi \in \text{Pth}_{\text{init}}(\mathcal{D}_\psi^\psi)$  there is exactly one sequence of automaton states  $\tau \in Q^\infty$  such that  $|\pi| = |\tau|$  and  $\tau \circ \pi \in \text{Pth}_{\text{init}}(\mathcal{D}_\varphi)$ .*

**PROOF.** The claim follows from the fact that, according to the definition of  $Mv^\varphi$ , the first component of each position of a path on  $\mathcal{D}_\varphi$  is univocally determined by the second component of that position and by the previous position in the path (the fact that  $\mathcal{D}_\psi$  is deterministic plays an important role in this). More formally,  $\tau$  is constructed inductively as:  $(\tau)_0 = q_0$  is the initial state of  $\mathcal{D}_\psi$  and, for  $i \in \mathbb{N}$ , with  $i > 0$ :

$$(\tau)_i = \begin{cases} (\tau)_{i-1} & \text{if } (\pi)_i \neq \emptyset \\ \delta((\tau)_{i-1}, (\pi)_{i-1}) & \text{if } (\pi)_i = \emptyset \end{cases}$$

Clearly,  $\tau \circ \pi \in \text{Pth}_{\text{init}}(\mathcal{D}_\varphi)$  since  $\pi$  is a path on  $\mathcal{D}_\psi^\psi$  and  $\tau$  closely follow the move relation  $Mv^\varphi$ . It is also easy to see that for any other  $\tau' \in Q^\infty$ , with  $\tau' \neq \tau$ , it holds that  $\tau' \circ \pi \notin \text{Pth}_{\text{init}}(\mathcal{D}_\varphi)$ . Indeed, assume, towards a contradiction, that  $\tau' \circ \pi \in \text{Pth}_{\text{init}}(\mathcal{D}_\varphi)$ , and let  $i$  be the smallest index such that  $(\tau)_i \neq (\tau')_i$ . If  $i = 0$ , then  $((\tau')_i, (\pi)_i)$  is not the initial position of  $\mathcal{D}_\psi^\psi$  thus contradicting the assumption; if  $i > 0$  and  $(\pi)_i \neq \emptyset$ , we have:  $(\tau)_i = (\tau)_{i-1} = (\tau')_{i-1}$ , which implies  $(\tau')_{i-1} \neq (\tau')_i$ , and thus  $((\tau')_{i-1}, (\pi)_{i-1}), ((\tau')_i, (\pi)_i)$  is not a move of  $\mathcal{D}_\varphi$ , according  $Mv^\varphi$ , and the assumption

is contradicted; finally, if  $i > 0$  and  $(\pi)_i = \emptyset$ , we have  $(\tau)_i = \delta((\tau)_{i-1}, (\pi)_{i-1}) = \delta((\tau')_{i-1}, (\pi)_{i-1})$ , which implies  $(\tau')_i \neq \delta((\tau')_{i-1}, (\pi)_{i-1})$ , and the assumption is contradicted once again, since  $((\tau')_{i-1}, (\pi)_{i-1}, ((\tau')_i, (\pi)_i))$  is not a move of  $\mathcal{D}_\varphi$  for any  $(\tau')_i \neq \delta((\tau')_{i-1}, (\pi)_{i-1})$ , according  $MV^\varphi$ .  $\square$

**Corollary 5.** *Function  $f : \text{Pth}_{\text{init}}(\mathcal{D}_\varphi) \rightarrow \text{Pth}_{\text{init}}(\mathcal{D}_\varphi^\psi)$  is a bijection.*

We define now a bijection  $\kappa$  from strategies (for both Eloise (E) and Abelard (A)) in  $\mathcal{D}_\varphi$  to strategies in  $\mathcal{D}_\varphi^\psi$ . For  $\alpha \in \{E, A\}$ , let  $\text{Hst}_\alpha(\mathcal{D}_\varphi)$  and  $\text{Hst}_\alpha(\mathcal{D}_\varphi^\psi)$  be the sets of histories for  $\alpha$  (i.e., the sets of finite initial paths terminating in an  $\alpha$ -position) in  $\mathcal{D}_\varphi$  and  $\mathcal{D}_\varphi^\psi$ , respectively, and let  $\text{Str}_\alpha(\mathcal{D}_\varphi)$  and  $\text{Str}_\alpha(\mathcal{D}_\varphi^\psi)$  be the sets of strategies for player  $\alpha$  in  $\mathcal{D}_\varphi$  and  $\mathcal{D}_\varphi^\psi$ , respectively. Observe that  $\text{Hst}_\alpha(\mathcal{D}_\varphi) \subseteq \text{Pth}_{\text{init}}(\mathcal{D}_\varphi)$  and  $\text{Hst}_\alpha(\mathcal{D}_\varphi^\psi) \subseteq \text{Pth}_{\text{init}}(\mathcal{D}_\varphi^\psi)$ . We define  $\kappa : \text{Str}_\alpha(\mathcal{D}_\varphi) \rightarrow \text{Str}_\alpha(\mathcal{D}_\varphi^\psi)$  as follows: for every  $\sigma \in \text{Str}_\alpha(\mathcal{D}_\varphi)$  and every history  $\rho \in \text{Hst}_\alpha(\mathcal{D}_\varphi^\psi)$ , we set  $\kappa(\sigma)(\rho) = \text{proj}_2(\sigma(f^{-1}(\rho)))$ . Intuitively,  $\kappa(\sigma)$  acts like  $\sigma$  restricted to the second component of positions.

**Claim 12.** *Function  $\kappa : \text{Str}_\alpha(\mathcal{D}_\varphi) \rightarrow \text{Str}_\alpha(\mathcal{D}_\varphi^\psi)$  is a bijection.*

**PROOF.** In order to see that  $\kappa$  is injective, we show that  $\sigma \neq \sigma'$  implies  $\kappa(\sigma) \neq \kappa(\sigma')$ , for every  $\sigma, \sigma' \in \text{Str}_\alpha(\mathcal{D}_\varphi)$ . Let  $\sigma, \sigma' \in \text{Str}_\alpha(\mathcal{D}_\varphi)$  and let  $\rho \in \text{Hst}_\alpha(\mathcal{D}_\varphi)$  be such that  $\sigma(\rho) \neq \sigma'(\rho)$ . We first prove that  $\text{proj}_2(\sigma(\rho)) \neq \text{proj}_2(\sigma'(\rho))$ . Let  $\rho = \rho(q, \xi)$  with  $\rho$  potentially empty. Let  $\sigma(\rho) = (q^*, \xi^*)$  with  $q^* = q$  if  $\xi^* \neq \emptyset$  and  $q^* = \delta(q, \xi)$  otherwise. Toward contradiction, suppose that  $\text{proj}_2(\sigma(\rho)) = \text{proj}_2(\sigma'(\rho)) = \xi^*$ . Then, by definition,  $\text{proj}_1(\sigma(\rho)) = \text{proj}_1(\sigma'(\rho)) = q^*$  and then  $\sigma(\rho) = \sigma'(\rho)$  which is a contradiction. Then, we have  $\kappa(\sigma)(f(\rho)) = \text{proj}_2(\sigma(\rho)) \neq \text{proj}_2(\sigma'(\rho)) = \kappa(\sigma')(f(\rho))$ , and therefore  $\kappa(\sigma) \neq \kappa(\sigma')$ .

In order to show that  $\kappa$  is surjective as well, let  $\sigma \in \text{Str}_\alpha(\mathcal{D}_\varphi^\psi)$ . We build a strategy  $\sigma' \in \text{Str}_\alpha(\mathcal{D}_\varphi)$  such that  $\kappa(\sigma') = \sigma$ . Intuitively,  $\sigma'$  returns a pair (a position in  $\mathcal{D}_\varphi$ ) whose second component is chosen according to the output of strategy  $\sigma$  in  $\mathcal{D}_\varphi^\psi$  and whose first component is univocally determined (thanks to Claim 11) by the choice of the second component and the argument history. Formally, for every  $\rho \in \text{Hst}_\alpha(\mathcal{D}_\varphi^\psi)$  we denote by  $\text{ext}(\rho)$  the initial path of  $\mathcal{D}_\varphi^\psi$  obtained by appending to  $\rho$  the output the strategy  $\sigma$  on  $\rho$  itself, i.e.,  $\text{ext}(\rho) = \rho \cdot \sigma(\rho)$ ; notice that  $f^{-1}(\text{ext}(\rho)) \in \text{Pth}_{\text{init}}(\mathcal{D}_\varphi)$ . Thus, we define  $\sigma'$  as:  $\sigma'(\rho) \triangleq \text{lst}(f^{-1}(\text{ext}(f(\rho))))$ , for every history  $\rho \in \text{Hst}_\alpha(\mathcal{D}_\varphi)$ . It is not difficult to see that  $\kappa(\sigma') = \sigma$ : indeed, it holds that  $\kappa(\sigma')(\rho) = \text{proj}_2(\sigma'(f^{-1}(\rho))) = \text{proj}_2(\text{lst}(f^{-1}(\text{ext}(\rho)))) = \text{proj}_2(\text{lst}(f^{-1}(\rho \cdot \sigma(\rho)))) = \sigma(\rho)$ , for every  $\rho \in \text{Hst}_\alpha(\mathcal{D}_\varphi)$ . This concludes the proof.  $\square$

The next claim states that the bijection  $\kappa$  preserves the possible plays resulting from the application of a strategy by Eloise in  $\mathcal{D}_\varphi$  and its image in  $\mathcal{D}_\varphi^\psi$  modulo the correspondence between plays of  $\mathcal{D}_\varphi$  and  $\mathcal{D}_\varphi^\psi$  established by the bijection  $f$ . Let  $\text{Play}(\mathcal{D}_\varphi)$  be the set of plays of  $\mathcal{D}_\varphi$ .

**Claim 13.**  *$\pi$  is compatible with  $\sigma$  iff  $f(\pi)$  is compatible with  $\kappa(\sigma)$ , for every  $\sigma \in \text{Str}_E(\mathcal{D}_\varphi)$  and  $\pi \in \text{Play}(\mathcal{D}_\varphi)$ .*

**PROOF.** It is easy to verify that a play  $\pi \in \text{Play}(\mathcal{D}_\varphi)$  is compatible with a pair of strategies  $(\sigma_E, \sigma_A) \in \text{Str}_E(\mathcal{D}_\varphi) \times \text{Str}_A(\mathcal{D}_\varphi)$  if and only if  $f(\pi)$  is compatible with  $(\kappa(\sigma_E), \kappa(\sigma_A))$ . The thesis immediately follows.  $\square$

As a final ingredient in our proof, we establish a correspondence  $g$  between plays of  $\mathcal{D}_\varphi$  that are won by Eloise and models of  $\psi$ , recognised by  $\mathcal{D}_\psi$ . Function  $g : \text{Play}(\mathcal{D}_\varphi) \rightarrow \text{Val}(\text{ap}(\varphi))^\omega$  is defined as:  $g(\pi) \triangleq \text{obs}(f(\pi))$  for every  $\pi \in \text{Play}(\mathcal{D}_\varphi)$ . The correctness of such a correspondence is stated in the next claim.



**Claim 14.**  $\pi$  is won by Eloise in  $\mathcal{D}_\varphi$  iff  $g(\pi)$  is recognised by  $\mathcal{D}_\psi$ , for every  $\pi \in \text{Play}(\mathcal{D}_\varphi)$ .

PROOF. By the definition of  $\mathcal{D}_\varphi$ , if we restrict a play  $\pi \in \text{Play}(\mathcal{D}_\varphi)$  to those position  $(q, \xi) \in P_S^\varphi$  where  $\xi \in \text{Val}(\text{ap}(\varphi))$  (thus discharging partial valuations, which do not assign a truth value to all propositions occurring in  $\psi$ ), we obtain a sequence  $\pi'$  that encodes to the unique run of  $\mathcal{D}_\psi$  on  $f(\pi)$ , where the sequence  $(\pi')_{|_1}$  of first components of each position (i.e.,  $(\pi')_{|_1} \triangleq \langle \text{proj}_1((\pi')_i) \rangle_{i \in \mathbb{N}}$ ) corresponds to the states visited by the automaton while reading the word  $(\pi')_{|_2}$  corresponding to the sequence of second components of the positions in  $\pi'$  (i.e.,  $(\pi')_{|_2} \triangleq \langle \text{proj}_2((\pi')_i) \rangle_{i \in \mathbb{N}}$  – recall that  $\mathcal{D}_\psi$  is deterministic). Importantly, notice that such word  $(\pi')_{|_2}$  is exactly  $g(\pi)$ . Additionally, observe that the projections of  $\pi$  and  $\pi'$  on the first component of each position, i.e.,  $(\pi)_{|_1} \triangleq \langle \text{proj}_1((\pi)_i) \rangle_{i \in \mathbb{N}}$  and  $(\pi')_{|_1}$  respectively, are equal if we ideally merge together consecutive occurrences of the same state. This means that, since the winning condition  $\text{Wn}_\varphi$  of  $\mathcal{D}_\varphi$  mimics the acceptance condition  $\text{Acc}$  of  $\mathcal{D}_\psi$ , the sequence of priorities corresponding to  $\pi$  is the same as the one corresponding to the run  $\pi'$  of  $\mathcal{D}_\psi$  on  $g(\pi)$ . Therefore,  $g(\pi)$  is recognised by  $\mathcal{D}_\psi$  if and only if run  $\pi'$  is accepting if and only if play  $\pi$  is won by Eloise.  $\square$

Finally, from Claim 13 and the following one, whose proof makes use of Claim 14, it follows that there is a strategy for Eloise to win  $\mathcal{D}_\varphi$  if and only if there is a strategy for her to win  $\mathcal{D}_\varphi^\psi$ . Thanks to this last equivalence and to Theorem 4 we conclude that for every behavioral GFG-QPTL sentence  $\varphi$  there is a parity game won by Eloise if and only if  $\varphi$  is satisfiable.

**Claim 15.**  $\pi$  is won by Eloise in  $\mathcal{D}_\varphi$  iff  $f(\pi)$  is won by Eloise in  $\mathcal{D}_\varphi^\psi$ , for every  $\pi \in \text{Play}(\mathcal{D}_\varphi)$ .

PROOF. Consider a play  $\pi \in \text{Play}(\mathcal{D}_\varphi)$ . Thanks to Claim 14, we know that  $\pi$  is won by Eloise iff  $g(\pi)$  is accepted by  $\mathcal{D}_\psi$  which means that  $\text{wr}d^{-1}(g(\pi)) \models \psi$ , which, in turn, is equivalent to say that  $g(\pi) \in \text{Wn}_\varphi^\psi = \text{wr}d(\Psi)$ , that is,  $f(\pi)$  is won by Eloise in  $\mathcal{D}_\varphi^\psi$  since  $g(\pi) = \text{obs}(f(\pi))$ .  $\square$

The automaton  $A_\psi$  has a size exponential in the size of  $\psi$  [82]. The procedure to transform it into a deterministic parity automaton adds one exponential [69]; thus  $|\mathcal{D}_\psi| = 2^{2^{\alpha(|\psi|)}}$ . It is easy to see the number of positions of the quantification game is  $O(2^{|\varphi|})$ . Thus, we conclude that game  $\mathcal{D}_\varphi$  we have just defined has size in  $O(2^{|\varphi|} \cdot 2^{2^{\alpha(|\psi|)}}) = 2^{2^{\alpha(|\varphi|)}}$ . The game has the same number of priorities as the automaton  $\mathcal{D}_\psi$  which is in  $2^{\alpha(|\psi|)}$ .  $\square$